

Application Note:
 Protection of Medium-Power Motors
 With SIPROTEC Compact 7SK80

Motor settings using the SIPROTEC Compact motor protection relay 7SK80 is explained below. Information is given on how to use the motor's existing technical data to derive meaningful settings. Among other things, dynamic cold load pickup to reduce overcurrent settings during normal operation is explained. As an option, an internal RTD card or an external RTD-box can be used to directly monitor the stator and bearing temperatures via temperature sensors.



Fig.1: SIPROTEC Compact 7SK80

1. SIPROTEC Compact 7SK80

The SIPROTEC Compact motor protection relay 7SK80 offers motor protection functions for medium-power motors with the following scope:

Parameter no.	Protection function	ANSI no.
112	Time-overcurrent protection, phase	50,51
113	Time-overcurrent protection, ground	50N,51N
116	Directional ground fault protection	67N(s),59N
117	Dynamic cold load pickup	
140	Negative sequence protection	46
141	Motor starting protection	48
142	Thermal overload protection	49
143	Motor restart inhibit	66,49R
144	Load jam protection	51M
150	Undervoltage protection	27
190	Temperature monitoring	38
191	External temperature input connection type	

2. Available motor data

Not all data are available in our example. Unfortunately, this all too frequently reflects reality, for example when a motor has been in operation for a very long time and complete documentation is no longer available or only the data on the motor's rating plate are available.

Given:

Compressor motor for compressed air in an industrial plant:

Size	Value
Power	780kW
Rated voltage	10kV
Motor rated current	54A
Max. starting current (at 100% Vn)	250A
Starting time (at 100% Vn)	5sec
Heating time constant	40min
Cooling time constant at standstill	140min
Max. continuous thermal rating current	60A
Max. blocked rotor time	10sec

3. General power system data

The current and voltage transformer data and the type of connection are entered in the unit under "Power System Data 1".

- Current transformer 75A/1A
- Core-balance current transformer 60A/1A
- Voltage transformer 10kV/100V
- Isolated power system

Parameter	Value
0213 Voltage transformer connection	Vab, Vbc, Vn
0204 Transformer rated current, phase primary	75A
0205 Transformer rated current, phase secondary	1A
0217 Transformer rated current, ground primary	60A
0218 Transformer rated current, ground secondary	1A
0202 Transformer rated voltage, primary	10kV
0203 Transformer rated voltage, secondary	100V

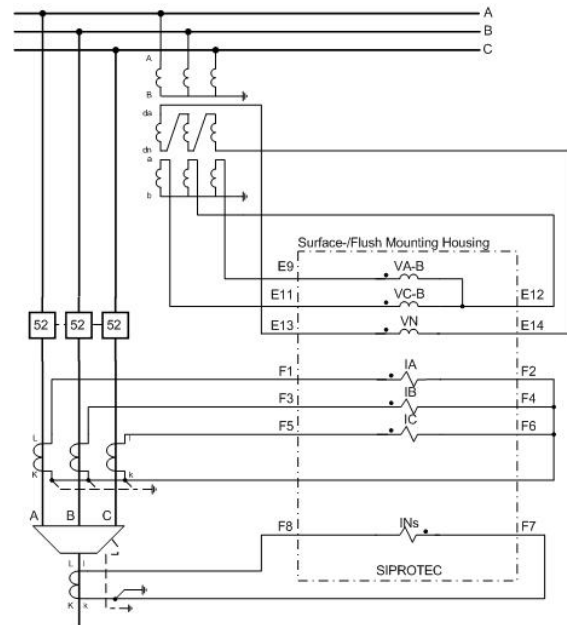

Fig.2: Connection diagram 7SK80

4. Motor starting protection

The settings for the motor starting protection require the starting current and the starting time. In our example, the blocked rotor time is not critical because it is longer than the starting time (10sec in comparison to 5sec). The associated setting for the locked rotor time is deactivated (key in a lower-case "o" twice for infinite). The motor starting protection can quickly respond to a blocked rotor, and external wiring with a speed monitor is dispensed with. As the guaranteed starting time (5sec) and the maximum blocked rotor time (10sec) are specified in the technical data, the protection setting must lie in between. In our specific case, the value 7sec was chosen. Taking the current transformer ratio into account, the maximum starting current is calculated as $I_{Start} = 250A/75A = 3.33$.

Parameter	Value
4102 Maximum startup current	3.33
4103 Maximum startup time	7sec
4104 Locked rotor time	oo

5. Thermal overload protection

Typical characteristic quantities designate the overload function, namely: maximum permissible continuous operating current, heating (heat-gain) time constant and cooling time constant at standstill. The maximum current is often not specified in the technical data. According to experience, a setting 10% above $I_{N, Motor}$ can be used and, in our case, $I_{N, Motor, max} = 60A$ is already specified. Hence the

k-factor (parameter 4202) is $I_{Motor, max} / I_{N, CT, prim} = 60A/75A = 0.8$.

The 40min heating time constant can be adopted directly as the setting. The overload protection function also takes cool-down behavior into account because different prerequisites for the motor (with or without fan) produce differing cool-down behavior. The value is set under parameter 4207A as a heating to cooling factor, i.e. $140min/40min = 3.5$.

The thermal warning stage, parameter 4204, offers an additional warning before tripping. This is why it should be set to below the 100% tripping threshold. On primary side the k factor is given by the ratio of maximum continuous thermal rating current to motor rated current ($k=60A/54A=1.11$). The thermal value at rated current is calculated as $1/k^2=1/(1.11 \cdot 1.11)=0.81$.

Therefore parameter 4204 must be set higher than the calculated value. In our specific case we select 90%.

The current alarm stage (Parameter 4205) can be set as the maximum continuous thermal rating current ($60A/75=0.8A$).

Parameter 4208A, dropout time after emergency starting, is active only if coupling in via a binary input has been realized, so as to allow emergency starting for the overload protection function despite the presence of an overload TRIP signal.

Parameter	Value
4202 k factor	0.8
4203 Time constant	40min
4204 Thermal alarm stage	90%
4205 Current alarm stage	0.8A
4207A Kt time factor at motor standstill	3.5
4208A Dropout time after emergency starting	100sec

Under System Data 2 there is an important setting that defines the interplay of overload protection and motor starting protection (parameter 1107). The overload protection function is active up to this setting, the device detects higher current values as motor starting, the motor starting protection runs and the thermal overload model does not increase any further. It is advisable to set the value to approximately 50 % of the starting current (in our case $250A/2 = 125A$, taken into account as the secondary value with the current transformer ratio of $75A/1A = 1.66A$). Thus, starting at low rated voltage is detected and protection is provided against sufficiently high overloads above the maximum current (110 % of I_N).

1107 Motor starting current (blk overload)	1.66A
--	-------

Direct measurement of temperatures

Either 5 internal RTD inputs (devices 7SK805 and 7SK806) or up to 12 RTD inputs through external RTD boxes can be applied for temperature detection. Thus, the thermal state can be monitored, in particular on motors, generators and

transformers. The bearing temperatures of rotary machines are also checked to detect when limit values are exceeded. Temperatures are measured by sensors at different points on the protected object and are fed to the device.

By way of example we consider an application with 5 temperature sensors (Figure 3):

The ambient or coolant temperature can be fed to the overload protection function of the 7SK80. To this end, the necessary temperature sensor must be connected to sensor input 1 of 7SK805 or 7SK806. Since 50% of all motor failures are caused by overheating of the bearings, normally redundant sensors are used there. These sensors are connected to the RTD inputs 2 to 5. The stator temperature is calculated in by the current through the stator windings. Large motors might request a stator temperature measurement per phase. For this an RTD box with 12 RTD inputs can be connected either through RS485 on Port B (RTD box type 7XV5662-6AD10) or Ethernet Port A (RTD box type 7XV5662-8AD10).

Figure 4 shows an alternative application of 7SK805 or 7SK806 with 5 internal RTD inputs: The stator temperature is measured by one temperature sensor per phase. Two further temperature sensors are used for the bearings.

As all calculations are run with scaled quantities, the ambient temperature must also be scaled. The temperature at rated current is used as the scaling quantity. If the rated current deviates from the rated

transformer current, the temperature must be adjusted with the help of the following formula under parameter 4209, "temperature at rated current".

$$\vartheta_{Nsecondary} = 80^{\circ}\text{C} \cdot (75/54)^2 = 154^{\circ}\text{C}$$

Parameter	Value
4209 Temperature at rated current	154°C

$$\vartheta_{Nsecondary} = \vartheta_{N,M} \cdot \left(\frac{I_{Nprim}}{I_{N,M}} \right)^2$$

For example $\vartheta_{N,M}=80^{\circ}\text{C}$ (obtained by measurement), then

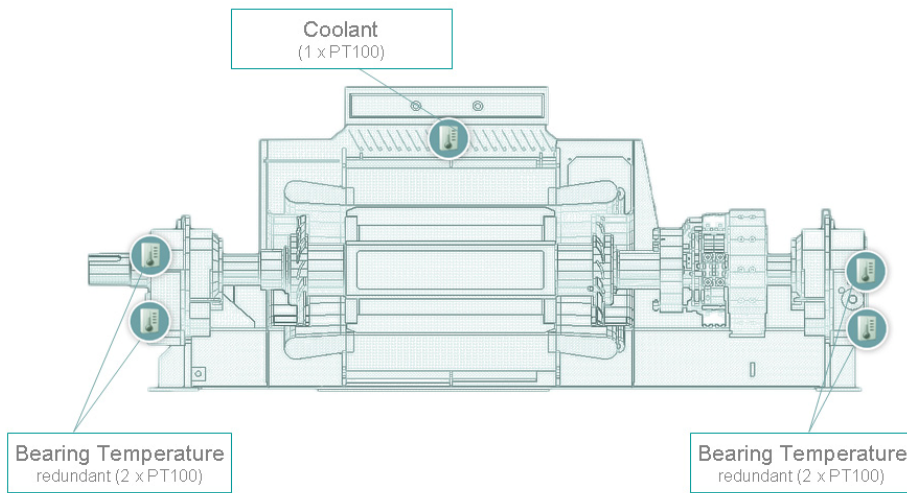

Fig.3: Application with 5 temperature sensors for bearings and coolant

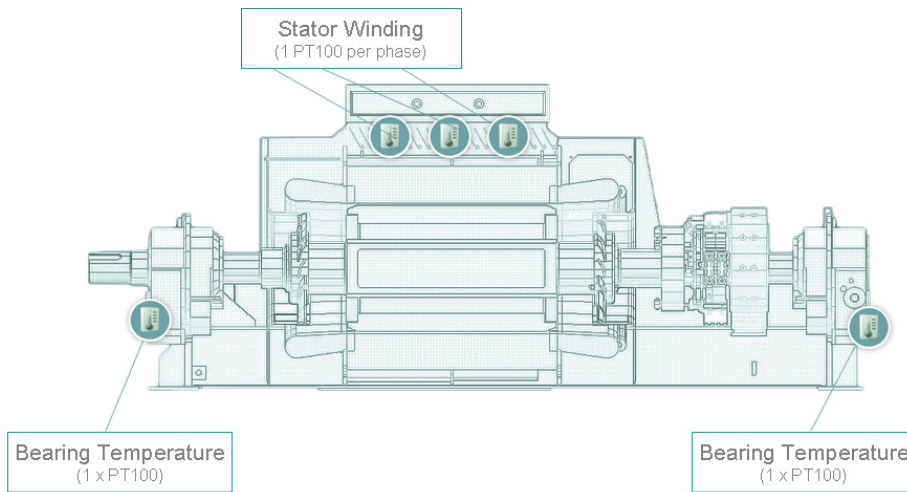

Fig.4: Application with 5 temperature sensors for stator windings and bearings

Load jam protection for motors (ANSI 51M)

A sudden high load may lead to deceleration or even rotor blocking that causes mechanical damages. The sudden rise in current is detected by the load jam protection function and can initiate an alarm or a trip. The thermal overload protection is too slow and therefore improper in this case.

The load jam threshold value of the tripping element (parameter 4402) is usually configured below motor startup at double motor ampere rating. In our example Parameter 4402 will then be $2 \cdot 54A/75=1.44A$. The load jam warning element (parameter 4404) is naturally set below the tripping element, to approximately 75% of the tripping element. In our example parameter 4404 is $0.75 \cdot 1.44A=1.08A$.

Due to the threshold setting below the motor startup current, the load jam protection must be blocked during motor startup. Through parameter 212 "BkrClosed I MIN" motor standstill is detected. In this condition the load jam protection is blocked. After having closed the circuit breaker, the blocking is maintained during motor startup by parameter 4406. In order to avoid malfunctioning, it is set to the double startup time. In our example we will get $2 \cdot 5sec=10sec$.

Parameter	Value
4402 Load Jam Tripping Threshold	1.44A
4403 Load Jam Trip Delay	1.00sec
4404 Load Jam Alarm Threshold	1.08A
4405 Load Jam Alarm Delay	1.00sec
4406 Load Jam Blocking after motor start	10.00sec

6. Motor restart Inhibit

To protect the rotor a second thermal model is created in the motor restart inhibit function. The main focus is placed on the number of starts from the cold and warm states. These data are not available in our case and so three cold starts (*nc*) and two warm starts (*nw*) are assumed.

The rotor temperature equalization time (parameter 4304) defines the minimum dead time between individual starts. For this parameter 1min has proven to be a good value. Parameter 4302 – the quotient of starting current to rated motor current - results in $250A/54A = 4.6$.

The maximum permissible starting time (parameter 4303) can be taken directly from the motor data (5sec). The rated motor current is calculated as $I_{N, Motor} / I_{N, CT, prim} = 54A/75A=0.72$.

If data are not available, the cool-down behavior for the motor restart inhibit function can be assumed similarly to the cool-down behavior for overload protection. In the case of overload protection, this was

$140\text{min}/40\text{min}=3.5$. For the motor restart inhibit function, this is entered under parameter 4308.

Parameter 4309, "Extension of time constant at running", takes effect when activation of the motor was successful and then the motor continues to run in rated operation. Cooling for this is clearly shorter than under parameter 4308 because rotor operation involves intrinsic cooling, and so we choose the factor 2.

After three starts in brief succession, the motor restart inhibit function then blocks and issues a release signal after a calculated dead time to enable reconnection once again. The internally calculated dead time depends on the respective load and, accordingly, may differ in length. Alternatively, it is possible to consciously specify a minimum inhibit time (for example, if the customer insists on additional safety factors). This is set under parameter 4310. In our example we use the default value of 6min.

Parameter	Value
4302 I Start / I Motor nominal	4.6
4303 Max. Permissible Starting Time	5sec
4304 Temperature Equalization Time	1.0min
4305 Rated Motor Current	0.72A
4306 Max. Number of Warm Starts	2
4307 Number of Cold Starts Minus Warm Starts	1
4308 Extension of Time Constant at Stop	3.5
4309 Extension of Time Constant at Running	2.0
4310 Min. Restart Inhibit Time	6.0min

7. Negative sequence (unbalanced-load) protection

As no further information is available, recommendation-based values are used. In the case of a definite-time tripping characteristic, these are:

10% I_2/I_N , Motor for warning or long-time delayed tripping and approx. 40% I_2/I_N , Motor for short-time delayed tripping.

The setting values have to be converted for the secondary side by using the transformation ratio of the current transformer (75A/1A). For parameter 4002 the lowest setting value is 0.1A. We recommend 20sec (parameter 4003) and 2sec (parameter 4005) for the corresponding delay times.

Parameter	Value
4002 Pickup Current I2>	0.1A
4003 Time Delay T I2>	20sec
4004 Pickup Current I2>>	0.29A
4005 Time Delay T I2>>	2sec

we choose $1.6 \cdot (250/75)A = 5.33A$. Time delay T I>> (parameter 1802) is selected at 50ms. Initially the peak value of the starting current may be even higher. With time delay T I>>, non-delayed, set at 0 ms, the I>>-stage should be set to $2.5 \cdot$ starting current. $1.1 \cdot (250/75)A = 3.67A$ is calculated for the I> stage.

8. Time-overcurrent protection

Only the phase time-overcurrent protection is considered; due to the “isolated power system” grounding, the ground function is covered by the sensitive ground-fault detection. In relation to the phase time-overcurrent protection settings, it must be noted that these must lie above the motor starting values. Due to the short-time occurring motor inrush, the I>> stage must even be set to $>1.5 \cdot$ starting current, and so

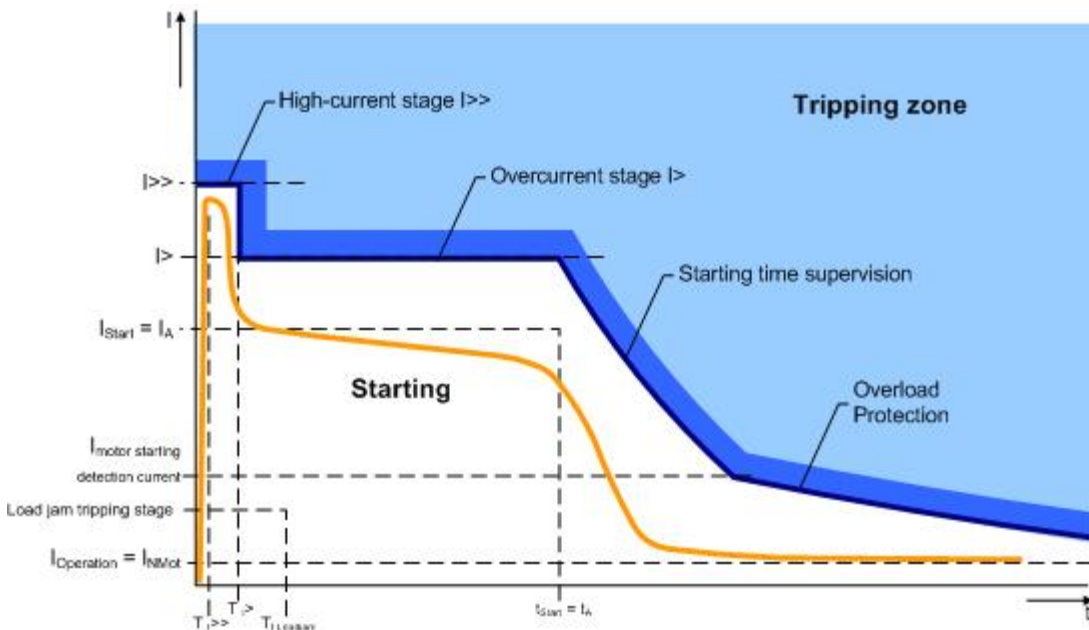

Fig.5: Coordination of protection functions (without dynamic cold load pickup)

If a short-circuit current occurs which lies at $2.5 \cdot I_{N, Motor}$, e.g. due to a contact resistance, the time-overcurrent protection will not pickup. But, as shown in Fig. 5, the motor starting protection will trip. A trip signal will be issued only after a few seconds (>7 seconds in our example), which can lead to enormous damage.

It is now possible to reduce the definite-time overcurrent settings during rated motor operation, so as to be able to respond more sensitively to all manner of current faults (see Fig. 6). To this end, the "Dynamic cold load pickup" option is used: During the normal state, i.e. when the motor is running, lower settings are valid which may already trigger (with a short delay) in the event of faults as from $1.5 \cdot I_{N, Motor}$ (depending on overload conditions). Two criteria are optionally available for detection of the deactivated system and thus changeover to high settings:

- The circuit-breaker position is communicated to the unit via binary inputs (parameter 1702 Start Condition = Breaker Contact).
- Falling below an adjustable current threshold (parameter 1702 Start Condition = No Current) is used.

The active time parameter 1704 must be set above the motor starting time. The reduced value for $I >$ (parameter 1204) results in $1.5 \cdot (54/75)A = 1.08A$.

Dynamic cold load pickup:

Parameter	Value
1703 CB Open Time	0sec
1704 Active Time	8sec
1801 Pickup Current $I >>$	5.33A
1802 Time Delay T $I >>$	0.05sec
1803 Pickup Current $I >$	3.67A
1804 Time Delay T $I >$	0.2sec

Definite time overcurrent protection:

Parameter	Value
1202 Pickup Current $I >>$	5.33A
1203 Time Delay T $I >>$	0.05sec
1204 Pickup Current $I >$	1.08A
1205 Time Delay T $I >$	1sec

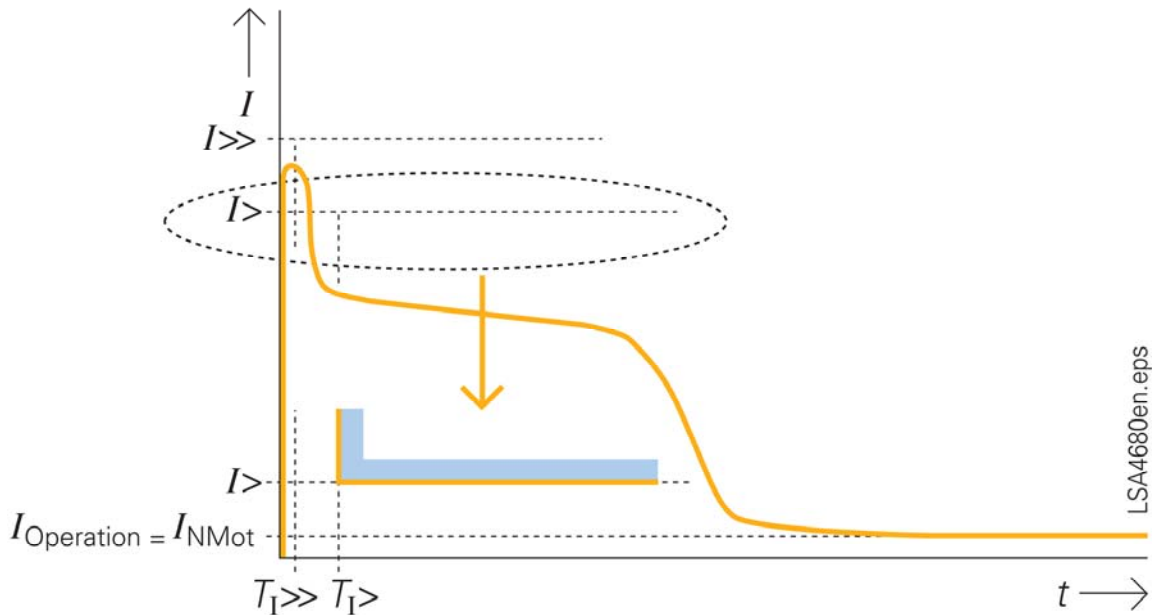

Fig.6: Reducing the time-overcurrent protection $I >$ stage during rated operation

Additional programming with PLC/CFC logic is not necessary. Changeover takes place automatically. To avoid tripping prematurely with the $I >$ stage 1204 in the event of short-time, substantial overloads (load jumps), the tripping time is set to 1 sec.

9. Sensitive ground-fault detection

Sensitive ground-fault detection includes a large number of settings, for example to exactly determine the displacement voltage or to correct transformer errors. We will consider only the essential settings for detection of a directional ground-fault. The other parameters can remain at default settings. The thresholds for the I_{Ns} current must be determined by way of the power system data. To this end, we need the cable lengths and types to calculate the capacitive ground current I_{CE} .

Sometimes a load resistor is also connected upstream, so as to arrive at an increased ground-fault current in the event of a displacement voltage. Let us assume a capacitive ground current I_{CE} of 20A. For a protection range of 90%, the protection should already operate at 1/10 of the full displacement voltage (parameter 3109 with $0.1 \cdot 100V = 10V$), where also only 1/10 of the ground-fault current results.

Therefore, $(20A/(60A/1A)) \cdot 0.1 \approx 0.035A$ is set for parameter 3117.

Because the high set element $I_{Ns} >>$ is not needed in our application example, we set it to the highest possible value (parameter 3113=1.6A) and the corresponding time delay to infinite (parameter 3114=∞).

With regard to determining the direction, note that the ground current flows in the direction of the protected motor when parameter 3122 "forward" and parameter 0201

“current transformer star point” in direction of “line” are selected and the ground CT is connected as shown in Fig. 2.

Parameter	Value
3113 Pickup Current INs>>	1.6A
3114 Time Delay T INs>>	oo
3117 Pickup Current INs>	0.035A
3118 Time Delay T INs>	5.00sec
3109 VGND> measured	10V
3122 Direction INs>	Forward
3125 Measurement Method	SIN Phi

10. Voltage protection

The motor still has to cope with up to about 80 % of the rated voltage and values below that lead to instability.

Parameter	Value
5103 Pickup Voltage V<	75V
5106 Time Delay T V<	1.5sec
5111 Pickup Voltage V<<	70V
5112 Time Delay T V<<	0.5sec

11. Summary

The motor protection functions of the SIPROTEC Compact 7SK80 derived from the current and voltage inputs result in a combination that offers users effective and low-cost all-round protection and which is very frequently utilized for medium-voltage motors in industry. Steps for transferring the motor data to 7SK80 setting data were discussed and the substitute settings suitable for characteristic motor variables were proposed.