

SIMEAS P Power Meter



SIMEAS P 610 with transparent front cover

Fig. 13/1
SIMEAS P power meters

SIMEAS P 50

Description

SIMEAS P is a power meter for panel mounting with graphic display and background illumination. The major application area is power monitoring and recording at MV and LV level. The major information types are measured values, alarms and status information.

Power monitoring systems with SIMEAS P, a permanently installed system, enables continuous logging of energy-related data and provides information on operational characteristics of electrical systems. SIMEAS P helps identify sources of energy consumption and time of peak consumption. This knowledge allows you to allocate and reduce energy costs.

Measured values include r.m.s values of voltages (phase-to-phase and/or phase-to-ground), currents, active, reactive and apparent power and energy, power factor, phase angle, harmonics of currents and voltages, total harmonic distortion per phase plus frequency and symmetry factor.

The SIMEAS P comes with two binary outputs, which can be configured for energy pulses, limit violations or status signals.

The unit is also able to trigger on settable limits. This function can be programmed for sampled or r.m.s values.

SIMEAS P generates a list of minimum, average and maximum values for currents, voltages, power, energy, etc.

Independent settings for currents, voltages, active and reactive power, power factor, etc. are also possible. In case of a violation of these limits, the unit generates alarms. Up to 6 alarm groups can be defined using AND/OR for logical combinations.

The alarms can be used to increase counter values, to trigger the oscilloscope function, to generate binary output pulses, etc.

Some device variants include further features

- Real-time clock.
- 1 MB memory management:
The allocation of the non-volatile measurement memory is programmable.
- Measured values and states will be recorded with time stamps.
- Recording and display of limit value violations.
- Log entries.

Battery:

Recordings like limit value violations or energy counter values stay safely in the memory up to 3 months in case of a black-out.

Function overview

SIMEAS P

- Power meter for panel mounting
- Measurement of voltage, current, active & reactive power, frequency, active & reactive energy, power factor, symmetry factor, voltage and current harmonics up to the 21st, total harmonic distortion
- Single-phase, three-phase balanced or unbalanced connection, four-wire connection
- PROFIBUS-DP or MODBUS RTU/ ASCII or IEC 60870-5-103 communication protocol
- Simple parameterization via front key or RS485 communication port using SIMEAS P PAR software
- Graphic display with background illumination with up to 20 programmable screens
- Battery
- Real-time clock

Selectable screen types

- 2, 3, 4 or 6 measured values in one screen
- One list screen for minimum, average and maximum values
- Two types of screens for harmonics
- One screen for oscilloscope function (sampled values or r.m.s values)
- One screen serving as phasor (vector) diagram
- Up to 20 screen types can be programmed. Switching from one screen to another can be automatic or manual

Description of SIMEAS P

Memory management

Memory Management		
> Mean values:	5%	533,3 d
> Power recording:	34%	1,1 d
> Oscilloscope:	15%	5,4 d
> Limit values:	38%	49664
> Binary states:	8%	10240
< OK		
< Cancel		

Due to the memory capacity (1 Mbyte) and the implemented memory management, it is possible to freely configure the measurement memory for mean values, power recordings, oscilloscope, limit value violations and binary states.

After the assignment of the percentage, the corresponding record time will be calculated and shown on the display automatically.

Recording of limit value violation

Bd/Prm	↺	↻	⏏	2/14
Limit	Time	↑↓	Reason	
4	13.11.02 23:20:10	↑↓		
V _{LN2}	13.11.02 22:40:12	↓	210,2 V	
V _{LN3}	13.11.02 22:40:07	↓	210,2 V	
V _{LN3}	13.11.02 22:40:02	↓		
V _{LN2}	13.11.02 22:40:01	↓		
V _{LN1}	12.11.02 08:22:41	↓	235,8 V	
V _{LN1}	12.11.02 08:22:40	↑		

In this screen, all limit value violations will be shown in chronological order.

Screen of Log entries

Bd/Prm	↺	↻	⏏	2/14
Reset	10.10.02 12:23:40			
Power on	10.10.02 12:25:20			
Settings	19.09.02 16:20:55			
Res. Limit	09.10.01 10:12:05			
Res. Mean	22.10.01 09:22:10			
Res. Energy	24.10.01 17:13:44			
Res. Osci.	12.06.01 08:56:15			
Clock	10.10.02 12:00:00			
< Cancel				

The most recent change of several status information will be displayed in the “Log” screen with date and time.

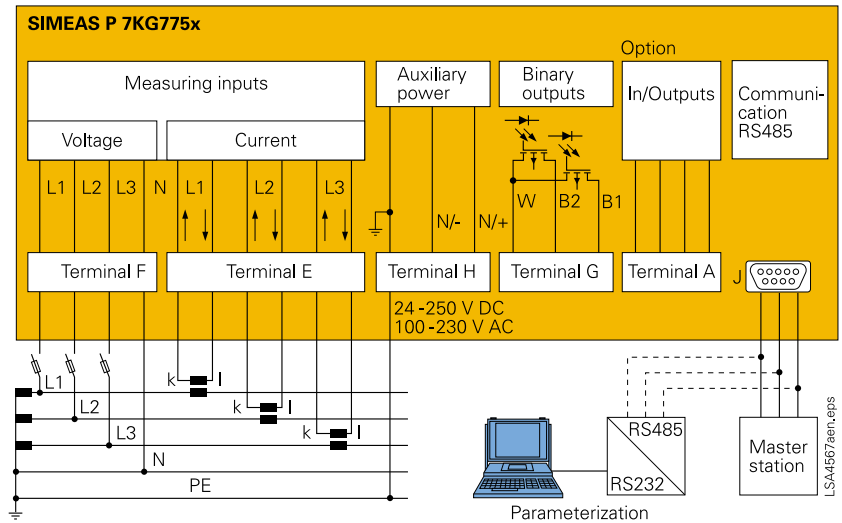

Fig. 13/2 Inputs / Outputs

Memory "read-out"

Recorded quantities and binary state information can be read out with the configuration software SIMEAS P PAR using the RS485 interface. Therefore a separate cable together with an RS232/RS485 converter is necessary. The configuration software offers features for indication and evaluation of all saved measured values and binary information. For further information, please refer to the chapter “SIMEAS P configuration software package” (pages 13/11 and 12).

Technology

Powerful on-board microprocessors ensure fast registration and updating of measured parameters.

SIMEAS P can be connected to any power system configuration directly (up to 690 V systems) or via transformer – from single-phase to four-wire balanced or unbalanced three-phase systems. SIMEAS P can be connected to any power system configuration up to 1 or 5 A or via current transformer.

The power supply unit allows rated supply voltages from 24 to 250 V DC and 100 to 230 V AC.

Display

All parameters can be displayed on the SIMEAS P screens as required by the user. Up to 20 screens can be defined and selected with the front keys.

Number, type, content and sequence of the screens are configurable.

SIMEAS P is delivered with programmed default settings. A status line displayed in the measured value screens indicates status, interfacing and diagnostic messages of SIMEAS P.

The display is automatically refreshed every 1 s.

Inputs / Outputs

Figure 13/3 shows the I/O pin configuration of SIMEAS P. Depending on the type of power system, the non required inputs remain unassigned.

Communication

As communication between field devices is becoming standard, the development of the SIMEAS P communication interface is focused on the universality and flexibility of the transmission protocol. It is connected via an RS485 port with standard 9-pin SUB-D connector. SIMEAS P units are delivered with a standard PROFIBUS-DP and MODBUS RTU/ASCII protocol. The communication protocol can be selected during the setting at the device. IEC 60870-5-103 protocol is also available for download.

Operation

Clear designations as well as menu-driven configuration guarantee simple and easy operation of the SIMEAS P.

Description of SIMEAS P610 and P50

Quality

Development and production of the device is carried out in accordance with ISO 9001, ensuring highest quality standard. That means high system reliability and product service life. Further characteristics are the constant high accuracy over years, CE designation, EMC strength, as well as the compliance with all relevant national and international standards.

Measuring functions

Measured input voltages and input currents are sampled for calculation of the corresponding r.m.s. values. All parameters derived from the measured values are calculated by a processor. They can be displayed on the screens and/or transmitted via the serial interface.

With the SIMEAS P it is also possible to define several limit value groups with different limit values for the measured parameters. These can be combined with logical elements, such as AND, OR. Violations are counted and indicated on the screen or made available at the binary outputs. Triggering of the oscilloscope is possible as well.

Security

Electrical isolation between inputs and outputs, assured by high-voltage testing, guarantees maximum system security.

Configuration and calibration settings are tamper-proof by password protection.

Service

SIMEAS P require no maintenance and are easy to service due to their modular design.

The units can easily be calibrated via the front keys or with PC-based configuration software.

Screens

20 screens can be selected on the display of SIMEAS P with the front keys. If requested, this routine can be executed automatically.

- Number, type and sequence of the screens are freely configurable.
- 9 different types of screens can be selected:
 - 2, 3, 4 or 6 measured-value screens
 - 1 list screen for minimum, average and maximum values

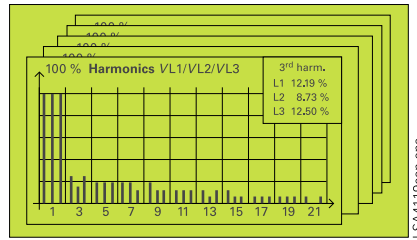

Fig. 13/3
Display up to 20 screens via front buttons (SIMEAS P610)

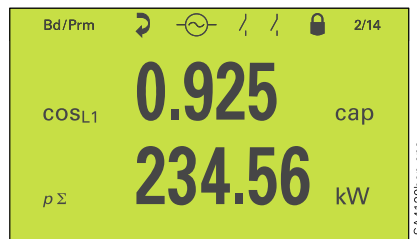

Fig. 13/4
2 measured values - digital (SIMEAS P610)

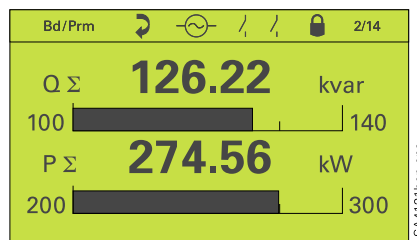

Fig. 13/5
2 measured values
digital / analog (SIMEAS P610)

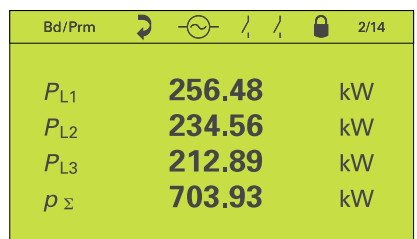
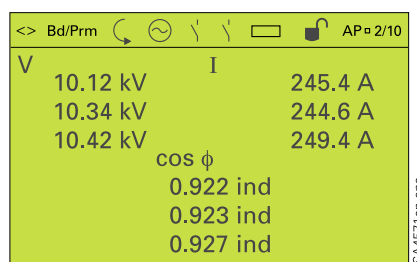

Fig. 13/6
4 measured values - digital (SIMEAS P610)



3 measured values - digital (SIMEAS P50)



V, I, cos φ (SIMEAS P50)

Description of SIMEAS P 610

- 2 screens for harmonics
- 1 screen serving as oscilloscope
- 1 screen serving as phasor diagram
- U , I , $\cos \varphi$ -screen

Measured-value screens

- Number and content of the measured-value screens and the parameters can be defined individually by the user.
- In addition, designations for the parameters are available for selection in the default setting:
 U_{L1} , U_{L2} , U_{L3} , $\cos \varphi$, or V_a , V_b , V_c , PF, etc.
- To obtain a higher resolution, the lower and upper measuring value can be set in the bar chart display.
- Status and diagnostic messages of the device are indicated in the status line displayed on the measured-value screens.
- The screens are automatically updated every 1 s.

Screens

Oscilloscope

- 3 parameters for voltage or current can be selected from the table of parameters (see page 13/8) and recorded with pre-fault.
- Recording is started manually or triggered automatically as soon as a limit value violation occurs.
- The cursor can be shifted with the front keys and the measured values with time indication from the cursor position and the X- and Y-axis can be read off.
- Also for recording of r.m.s. values, up to 3 parameters can be selected from the table of parameters.
- The parameter level is optimized automatically in the screens.
- The recording section displayed is indicated at the bottom of the oscilloscope screen.

Vector diagram

State and value of currents and voltages as well as their phase angles can be read off from the phase diagram screen.

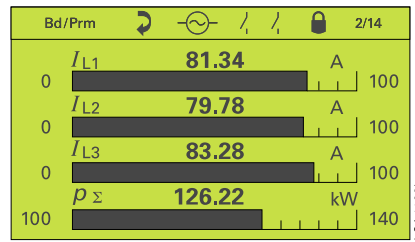

Fig. 13/7
4 measured values
digital / analog (SIMEAS P610)

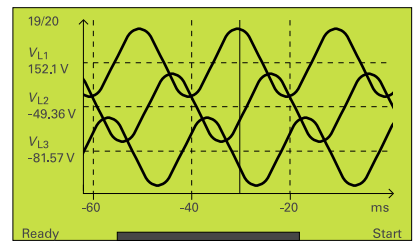

Fig. 13/8
Oscilloscope screen (SIMEAS P610)

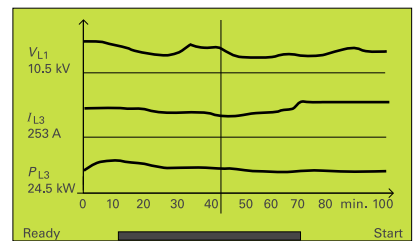

Fig. 13/9
Oscilloscope screen
for r.m.s. values (SIMEAS P610)

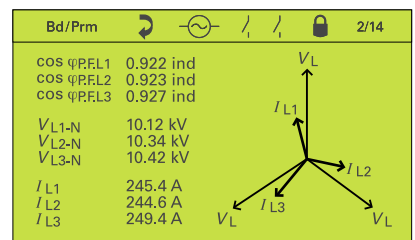

Fig. 13/10
Phasor diagram (SIMEAS P610)

Description of SIMEAS P 610

Screens

Harmonics

2 screens are available for the measured harmonics:

- Harmonic voltages
Harmonic currents
- All three phases with all odd order harmonics up to the 21st harmonic are displayed on the screens.
- Each harmonic can be indicated individually in a digital display in the top right-hand corner of the screen and can be selected via the front keys.

List screens

- Minimum, average and maximum values of the parameters are indicated on the list screens from the beginning of the recording.
- Start and reset of the recording process is done via the front keys.
- The parameters are freely configurable with regard to their number and sequence.

Configuration

- Configuration of SIMEAS P is very easy.
- Rapid configuration (even without consulting the manual) is possible due to detailed index and operation via cursor and enter key.
- Configuration and calibration settings are tamper-proof by password protection.

Communication

SIMEAS P is equipped with a communication port in compliance with the EIA standard RS485 with a standard 9-pin SUB-D connector for connection to RS485 field bus systems. The SIMEAS P comes with the following standard communication protocols:

- PROFIBUS-DP V1 protocol in compliance with EN 50170 Volume 2
- MODBUS RTU/ASCII and
- IEC 60870-5-103 for SIMEAS P50

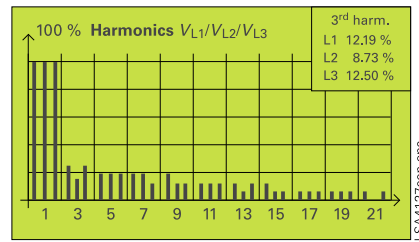

Fig. 13/11
Harmonics (SIMEAS P610)

Bd/Prm	Min.	Avg.	Max.	6:38
V_{L1}	0.00	0.00	18.90	V
V_{L2}	0.00	0.00	13.55	V
V_{L3}	0.00	0.00	14.77	V
V	0.00	0.00	15.74	V
V_{E-N}	104.0	104.0	105.2	V
V_{L1}	0.00	0.00	18.90	V
V_{L2}	0.00	0.00	13.55	V
V_{L3}	0.00	0.00	14.77	V

LSA4133ben.eps

Fig. 13/12
Listing screens (SIMEAS P610)

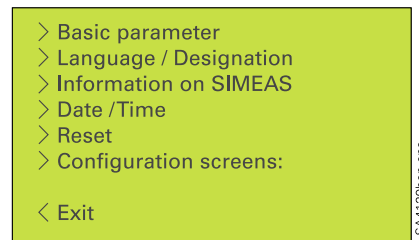

Fig. 13/13
Configuration

This option provides efficient and fast data

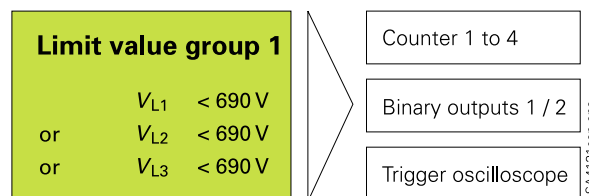

Fig. 13/14
Limit values

PROFIBUS-DP

PROFIBUS-DP and SIMEAS P are connected in a master-slave operation mode. The communication parameters are loaded to the master station using the GSD file.

The SIMEAS P supports data transmission rates from 9.6 kbit/s to 12 Mbit/s.

Optionally, the user may select different types of transmission for cyclic data transfer to the master station:

- Type 1: transmission of 3 measured values
- Type 2: transmission of 6 measured values
- Type 3: transmission of 12 measured values
- Type 4: transmission of 32 measured values

communication between SIMEAS P and the master station.

The 3, 6, 12 or 32 measured values for transmission types 1 to 4 can be selected from the table of parameters (page 13/8).

Limit values

Several limit value groups with up to 6 selectable parameters can be set in the SIMEAS P.

The values can be combined with logical elements such as AND/OR; limit value violations are counted, they are available at binary outputs or used for triggering the oscilloscope.

Description of SIMEAS P

Binary outputs

The standard SIMEAS P comes with 2 binary outputs which are free for configuration with:

- Status signals
- Energy values from the table of parameters
- Limit value violations

Other configurable parameters are, for example, pulse duration, hysteresis and pulse value of the energy parameter.

Measured values and tolerances

Measured values	Measuring path ¹⁾	Output to	Tolerances ²⁾
Voltage	L1-N, L2-N, L3-N, (N-E)	▼ ■ ● ○	± 0.1 ²⁾ % / ± 0.3 % ⁷⁾
Voltage	L1-L2, L2-L3, L3-L1, $\Sigma^3)$	▼ ■ ● ○	± 0.1 ²⁾ % / ± 0.3 % ⁷⁾
Current	L1, L2, L3, N, $\Sigma^3)$	▼ ■ ● ○	± 0.1 ²⁾ % / ± 0.3 % ⁷⁾
Active power P + import, - export	L1, L2, L3, Σ	▼ ■ ● ○	± 0.5 %
Reactive power Q + cap, - ind	L1, L2, L3, Σ	▼ ■ ● ○	± 0.5 %
Apparent power S	L1, L2, L3, Σ	▼ ■ ● ○	± 0.5 %
Power factor $ \cos \varphi ^4)$	L1, L2, L3, Σ	▼ ■ ● ○	± 0.5 %
Active power factor $\cos \varphi^4)$	L1, L2, L3, Σ	▼ ■ ● ○	± 0.5 %
Phase angle ⁴⁾	L1, L2, L3, Σ	▼ ■ ● ○	± 2 °
Frequency ⁵⁾	L1 - N	▼ ■ ● ○	± 10 mHz
Active energy demand	L1, L2, L3, Σ	▼ ■ ○	± 0.5 %
Active energy supply	L1, L2, L3, Σ	▼ ■ ○	± 0.5 %
Active energy, total	L1, L2, L3, Σ	▼ ■ ○	± 0.5 %
Active energy Σ , total	Σ	▼ ■ ○	± 0.5 %
Reactive energy, inductive	L1, L2, L3, Σ	▼ ■ ○	± 0.5 %
Reactive energy, capacitive	L1, L2, L3, Σ	▼ ■ ○	± 0.5 %
Reactive energy, total	L1, L2, L3, Σ	▼ ■ ○	± 0.5 %
Apparent energy	L1, L2, L3, Σ	▼ ■ ○	± 0.5 %
Unbalance voltage	four-wire system	▼ ■ ● ○	± 0.5 %
Unbalance current	four-wire system	▼ ■ ● ○	± 0.5 %
THD voltage	L1, L2, L3	▼ ■ ● ○	± 0.5 %
THD current	L1, L2, L3	▼ ■ ● ○	± 0.5 %
Harmonic voltage V 3 rd , 5 th , 7 th , 11 th , 13 th , 17 th , 19 th	L1, L2, L3	▼ ■ ● ○	± 0.5 %
Harmonic current I 3 rd , 5 th , 7 th , 11 th , 13 th , 17 th , 19 th	L1, L2, L3	▼ ■ ● ○	± 0.5 %
Limit value violations	Counter 1, 2, 3, 4	▼ ■	
Analog inputs ⁶⁾	external	▼ ■	0.5 %
Binary inputs ⁶⁾	external	▼ ■	

- ▼ Measured values can be displayed on measured value screens (only 7KG7750 and 7KG76)
- Measured values transmitted via communication protocols PROFIBUS DP + MODBUS
- Measured values selectable for list screens (7KG7750) and measured values selectable for list screens and oscilloscope (only 7KG76)
- Measured values transmitted via IEC 60870-5-103

- 1) Phases are displayed based on the type of connection.
- 2) Tolerances at reference conditions are applicable from 0.5 to 1.2 times nominal value.
- 3) Average value of all phases.
- 4) Measuring beginning with 2 % of the internal apparent power.
- 5) Measuring beginning with 30 % of the input voltage L1-N.
- 6) 7KG775x, 7KG7610 and 7KG7660 only.
- 7) Limit values for the complete temperature range referring to: 0.1 to 1.2 x nominal range.

Description of SIMEAS P55

The SIMEAS P can be ordered for snap-on mounting on a 35 mm DIN rail.
For carrying out the setting of the device the configuration software is necessary.



Fig. 13/15 SIMEAS P55

Description of SIMEAS P50/P55/P610/660

Input and output modules

The SIMEAS P50/P55/P610, or the P660 respectively, can be equipped with additional analog and digital input and output modules.

The SIMEAS P50/P55 comes with 1 slot where the module may be installed.

The SIMEAS P610/P660 comes with 4 slots where the modules may be installed.
For different application areas, 5 different modules are available.

Application

The input modules can be used for acquisition, display and further processing of external signals with a measurement range of 0-20 mA_{DC}.

Measured values can be shown together with their units on the display. Also the transmission of the current status of a measured signal to a central master station via PROFIBUS-DP V1 or MODBUS RTU/ASCII is possible.

In addition, mean values of all external analog channels as well as states of digital channels can be recorded and saved into the memory.

All recorded quantities and binary state information can be "read out" and evaluated with the configuration software SIMEAS P PAR.

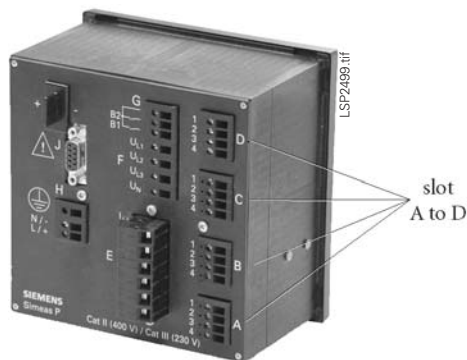

Fig. 13/16 SIMEAS P610/P660 with input and output modules

Output modules can be used for conversion of any electrical quantity (current, voltage, etc.) into a 0-20/4-20 mA_{DC} output signal, generation of impulses for metering, indication of limit value violations, as well as for switching operations.

Module assignment

The assignment of the different analog/digital modules can only be done in the course of an order of a SIMEAS P.

A change or a retrofit of modules of an existing SIMEAS P is not possible. Except for the relay module and the binary output module, the modules can be assigned to any of the 4 slots (A, B, C, D). Non-equipped slots are not used. (They may not be retrofitted either.)

Description of I/O modules

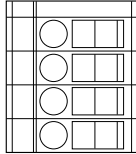
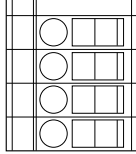
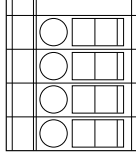
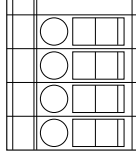
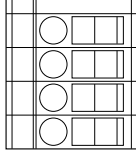
Description and applications	Terminal	Assignment
<p>Analog input module</p> <p>The SIMEAS P can be equipped with a maximum of 4 analog input modules. Each module comes with 2 analog input channels, designed for a rated measurement range of 0 to 20 mA_{DC}. The modules themselves are galvanically isolated against the internal circuit and also against each other. The two channels of the module are not galvanically isolated against each other.</p> <p>The analog input modules can be used for:</p> <ul style="list-style-type: none"> - Acquisition and display of measured signals with a measurement range of 0 to 20 mA_{DC} - Registration of limit value violations 	 <p>LSA4137en.eps</p>	<p>1 AI1+</p> <p>2 AI1-</p> <p>3 AI2+</p> <p>4 AI2-</p>
<p>Binary input module</p> <p>The SIMEAS P can be equipped with a maximum of 4 binary input modules. Each module comes with 2 galvanically isolated and rooted binary input channels. The input voltage will be transformed into a constant current.</p> <p>The binary input modules can be used for:</p> <ul style="list-style-type: none"> - Registration of binary states/messages - Time synchronization of the SIMEAS P 	 <p>LSA4138en.eps</p>	<p>1 BI1+</p> <p>2 BIR</p> <p>3 BIR</p> <p>4 BI2+</p>
<p>Analog output module</p> <p>The SIMEAS P can be equipped with a maximum of 4 analog output modules. Each module comes with 2 channels, designed for a rated measurement range of 0 to 20 mA_{DC}. The modules themselves are galvanically isolated against the internal circuit and also against each other. The two channels of the module are not galvanically isolated against each other.</p> <p>The analog output modules can be used for:</p> <ul style="list-style-type: none"> - Output of electrical quantities (current, voltage, power φ, $\cos \varphi$, frequency, etc.) between a rated measurement range of 0 to 20 mA_{DC} or 4 to 20 mA_{DC} 	 <p>LSA4137aen.eps</p>	<p>1 AO1+</p> <p>2 AO1-</p> <p>3 AO2+</p> <p>4 AO2-</p>
<p>Binary output module</p> <p>The SIMEAS P can be equipped with a maximum of 2 binary output modules. Each module comes with 2 rooted binary output channels, realized with 2 solid-state contacts.</p> <p>The binary output modules can be used for:</p> <ul style="list-style-type: none"> - Generation of impulses for metering - Indication of limit value violations - Indication of the device status - Indication of the rotation vector 	 <p>LSA4139en.eps</p>	<p>1 BOR</p> <p>2 BO1+</p> <p>3 BO2+</p> <p>4 unused</p>
<p>Relay output module</p> <p>The SIMEAS P can be equipped with a maximum of one relay output module. The relay output module comes with 3 rooted electromechanical contacts. With these contacts, higher power can be switched which is not possible when using the solid-state contacts. The relay contacts can be configured in the same manner as the channels of the binary output module.</p> <p>The relay contacts can be used:</p> <ul style="list-style-type: none"> - As a switch at limit value violations, e.g. compensation of reactive power 	 <p>LSA4140en.eps</p>	<p>1 RO1</p> <p>2 RO2</p> <p>3 RO3</p> <p>4 ROR</p>

Configuration software

Application

The SIMEAS P configuration software package enables a simple way to carry out the device settings. The package consists of the parameterizing software, a configuration cable with RS232/RS485 converter as well as a plug-in power supply for the converter. The SIMEAS P can be connected to any standard PC via the RS232/RS485 converter by means of a 9-pin SUB-D connector.

The software runs with Windows 2000 and XP Professional edition.

The configuration software permits a faster configuration of the SIMEAS P devices. The user can set and store parameters even without having a unit by his side. The parameters are transferred to the SIMEAS P by using the "Send to unit" command. Thus, a number of SIMEAS P units can be configured with minimum effort. The stored set of parameters is simply reloaded when a unit has to be replaced. Furthermore, firmware updates can be reloaded by means of the SIMEAS P configuration software.

The configuration package supports all SIMEAS P units and is absolutely essential for the devices SIMEAS P55/P6x.

Configuration of the measurement memory

Devices with measurement buffer offer the opportunity to record measured quantities and state information. Therefore, the configuration software enables menu items for the determination of values and state information which should be recorded.

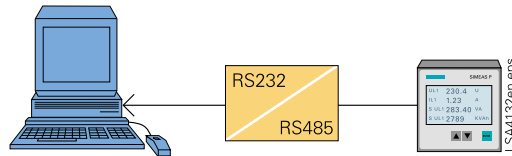

Fig. 13/17 Configuration

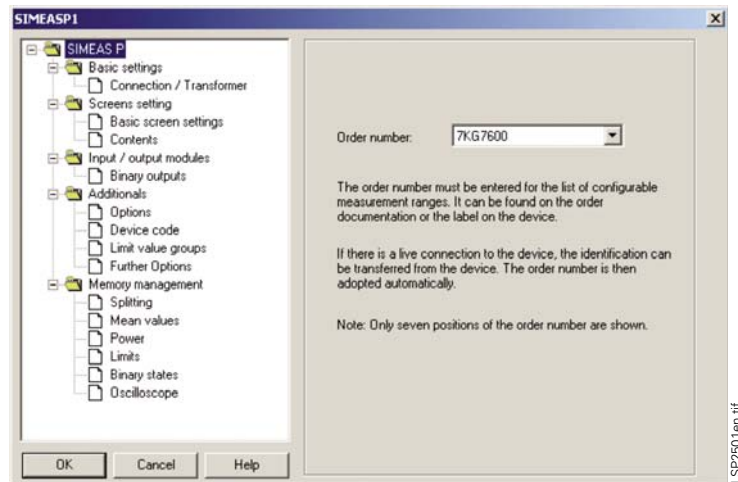

Fig. 13/18 Configuration

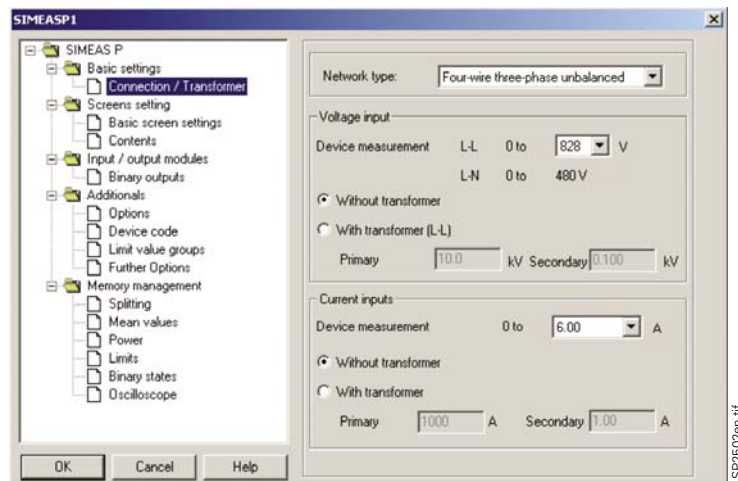

Fig. 13/19 Configuration

Configuration software

Memory read-out

Separate functions integrated in the configuration software, enable a read-out of the following information:

- Mean values
- Mean values of power
- Oscilloscope recordings
- State information of binary channels
- Limit value violations
- Log entries

Display and evaluation

All values and information read out via the software are shown automatically in tabular and graphical form together with the time stamp on the screen.

The context menu offers some functions (masking of signals, copy, zoom, measuring functions) for easy analysis of measured values and state information.

The following measured values can be shown in graphical form:

- Mean values of voltage and current
- Mean values of power
- Oscilloscope recordings
- State information of binary channels

The following information are shown in tabular form:

- Limit value violations
- Log entries

Export function

The software also enables a function for the export of transmitted values and state information into an ASCII-file. This ASCII-file can be used in other applications, e.g. MS-Excel. Oscilloscope recordings can be exported into COMTRADE formatted files.

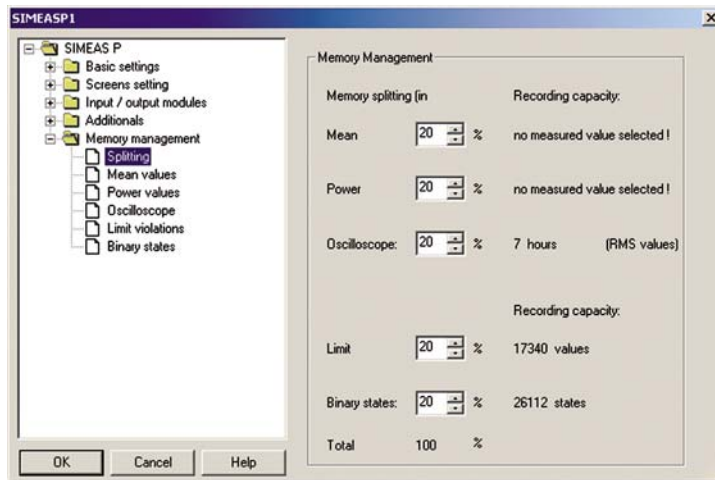

Fig. 13/20 Configuration of the measurement memory

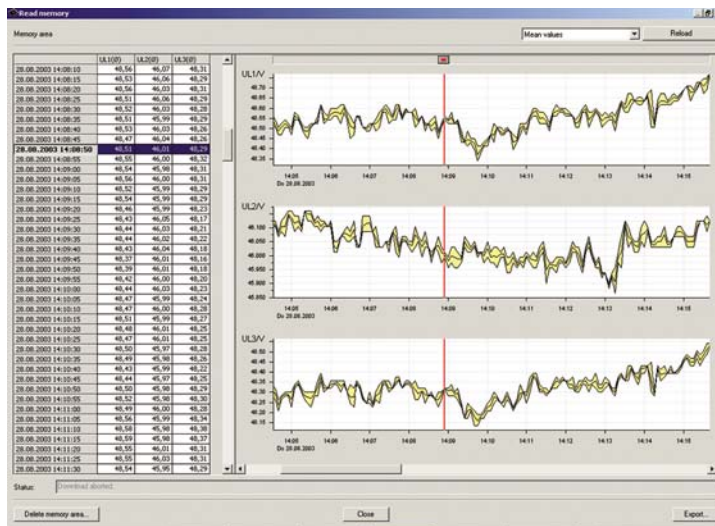

Fig. 13/21 Display and evaluation

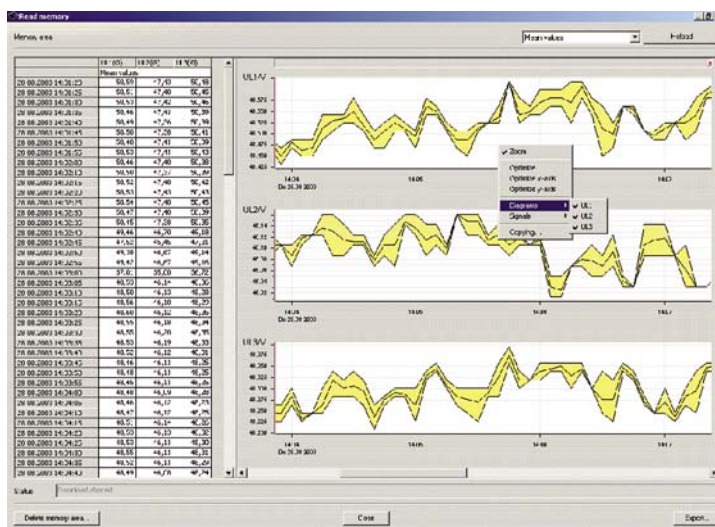

Fig. 13/22 Display and evaluation

Application

Application example 1

SIMEAS P as a panel-mounted device for direct electrical power monitoring.
 With a very simple configuration the display of measured values is adaptable to the specific requirements of the user.



Fig. 13/23
SIMEAS P with graphic display for panel mounting

Application example 2

SIMEAS P as a panel-mounted or snap-on mounted device for use on a process bus.
 Network linking is possible with the integrated RS485 port with the standard PROFIBUS-DP and MODBUS RTU/ASCII communication protocol. Furthermore, it is also possible to integrate SIMEAS P50 into communication networks with IEC 60870-5-103 as standard protocol. That allows several SIMEAS P measured parameters to be indicated, evaluated and processed at a central master station.

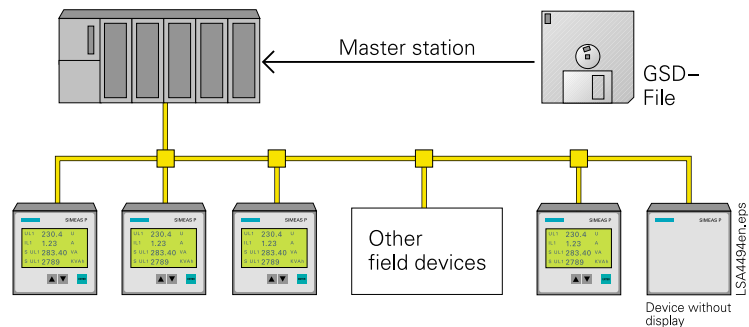

Fig. 13/24
SIMEAS P with PROFIBUS-DP

The major application area is the integration into PLC systems as a transducer.

Application example 3

Fig. 13/25 shows an example of extended IO for various applications.

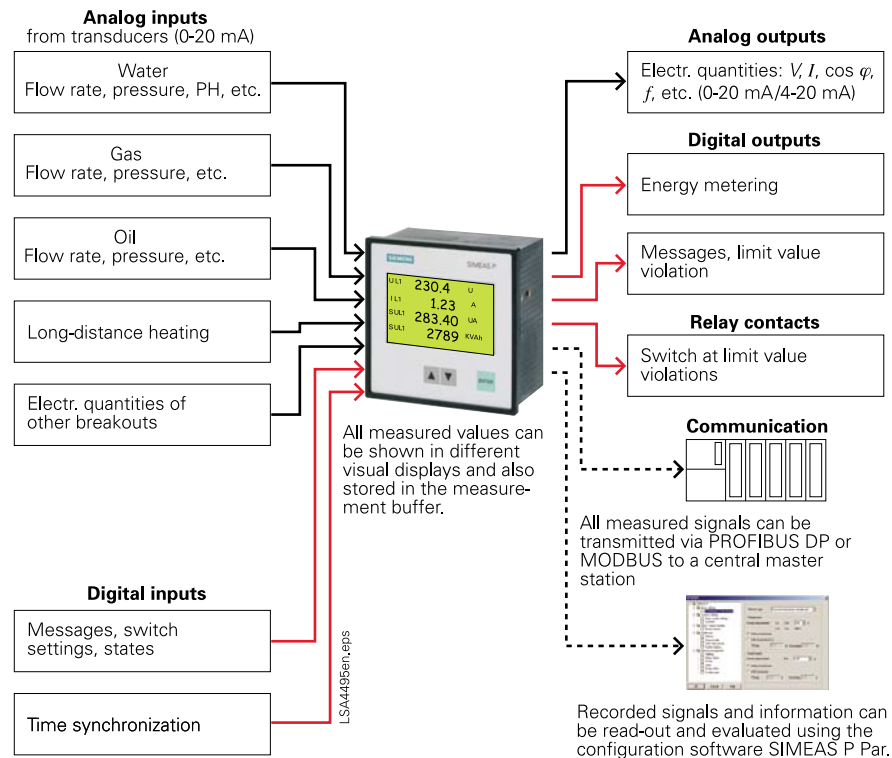

Fig. 13/25
SIMEAS P: Applications

SIMEAS P at a glance

Table 1 gives an overview of the features of the different SIMEAS P versions.

SIMEAS	P50	P55	P600	P610	P650	P660	P100 ^{*)}	P200 ^{*)}	P500 ^{*)}	P550 ^{*)}
Display	●		●	●	●	●			●	●
Housing	96 x 96	96 x 96	144 x 144	144 x 144	144 x 144	144 x 144	96 x 144	96 x 144	144 x 144	144 x 144
for panel mounting	●		●	●	●	●			●	●
for snap-on mounting on 35 mm DIN rail		●					●	●		
Battery buffered memory 1 MB and real time clock	●	●	●	●	●	●		●		
Recording limit value violations	●	●	●	●	●	●		●		
Log entries	●	●	●	●	●	●		●		
2 binary outputs	●	●	●	●	●	●	●	●	●	●
Number of slots for additional modules	1	1		4		4				
Protocols (RS485)										
MODBUS RTU/ASCII	●	●	●	●	●	●	●	●	●	●
PROFIBUS DP V1	●	●	●	●	●	●	●	●	●	●
IEC 60870-5-103	●	●								
Displays/screens										
Oscilloscope	● ²⁾	● ²⁾	●	●	●	●			●	●
Harmonics			●	●	●	●			●	●
Degree of protection										
IP41	●	IP20	●	●	●	●	●	●	●	●
IP54	IP65		●	●	● ¹⁾	● ¹⁾			●	● ¹⁾
UL Listing	●				●	●				●
Full parameterization via display	●								●	●

Table 1

1) With IP54 no UL Listing

2) With SIMEAS P PAR software

*) Devices are not described in this catalog – listed for reference purposes only.

Typical terminal assignments

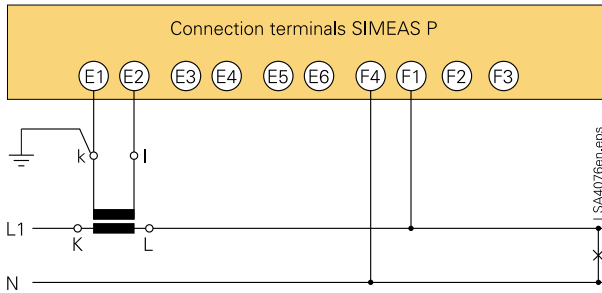

Fig. 13/26 Single-phase AC

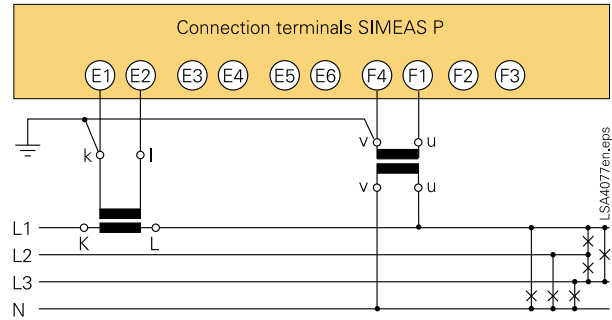

Fig. 13/27 4-wire-3-phase balanced

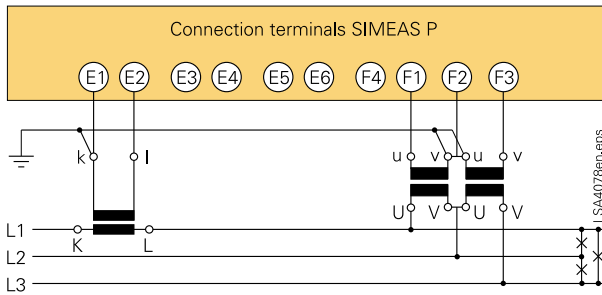

Fig. 13/28 3-wire-3-phase balanced

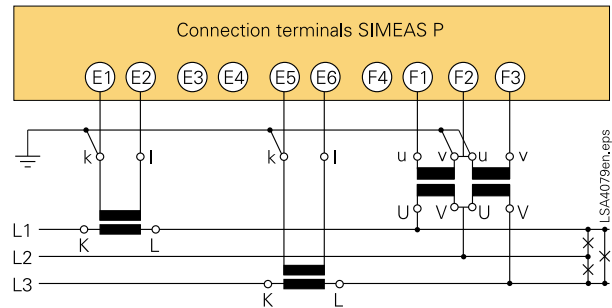

Fig. 13/29 3-wire-3-phase

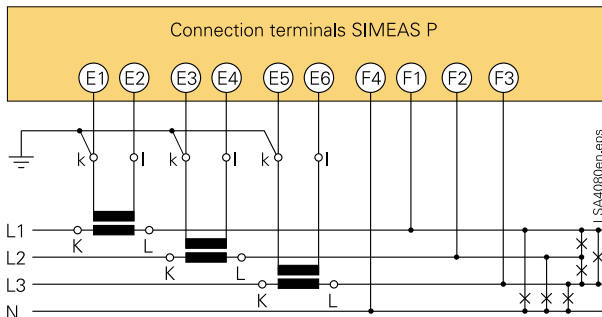

Fig. 13/30 4-wire-3-phase (low-voltage system) ¹⁾²⁾

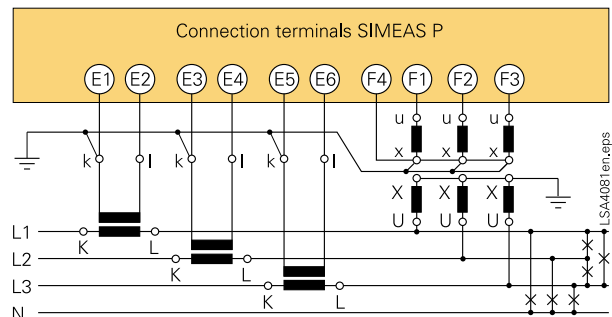

Fig. 13/31 4-wire-3-phase (high-voltage system)

The above-mentioned terminal assignments are just some configuration examples. Within the range of the permissible maximum current and voltage values, a current or voltage transformer is not compulsory.

On the other hand, Y or V-connected voltage transformers can be used. All input or output terminals not required for measurement remain unassigned.

Remarks regarding low-voltage applications:

1) Up to $V_{LN} = 480$ V, the SIMEAS P can be connected directly without a transformer. In three- and four-phase networks, except for three-phase networks without neutral: the SIMEAS P can also be connected directly without a transformer up to $V_{LL} = 690$ V.

2) In IT-low voltage systems SIMEAS P50 has to be connected via voltage transformer to avoid false alarm of isolator monitoring

Technical data

Input	for connection to AC systems only
Max. rated system voltage	Y 400 / Δ 690 V
Control range	1.2 V_{EN} / I_{EN}
Rated frequency f_{EN}	50 Hz; 60 Hz
Input frequency range f_E	± 5 Hz, min > 30 % V_{EN}
Waveform	sinusoidal or distorted up to the 21 st harmonic
AC current input I_E	3 current inputs
Rated input current I_{EN}	1 A; 5 A
Continuous overload	10 A
Surge withstand capability	100 A for 1 s
Power consumption	83 μVA at 1 A; 2.1 mVA at 5 A
AC voltage input V_E	3 voltage inputs
Rated voltage V_{EN}	100/110 V; 190 V; 400 V; 690 V (phase-phase)
Continuous overload capacity	1.5 V_{EN}
Surge withstand capability	2.0 x V_{EN}
Input resistance	2.663 MΩ
Power consumption	120 mW ($V_{LE} = 400$ V)
Surge voltage category	acc. to DIN EN 61010 Part 1
V_{EN} to 400 V (phase-earth)	III
V_{EN} to 690 V (phase-phase)	II
Auxiliary power	multi-range power supply AC / DC
Rated range	24 to 250 V DC or 100 to 230 V AC
Total range	± 20 % of rated range
Power consumption	
7KG7550/7KG7650/7KG775	max. 4 W or 10 VA
7KG7660	max. 10 W or 25 VA
Binary outputs	via isolated solid-state relay
Permissible voltage	230 V AC; 400 V DC
Permissible current	100 mA continuous 300 mA for 100 s
Output resistance	50 Ω
Permissible switching frequency	10 Hz
Measurement functions	
Sampling rate	3.6 kHz
Resolution	12 bit
Battery	
7KG72xx, 7KG76xx and 7KG77	Varta CR2032, 3 V, Li-Mn or similar
Real-time clock (7KG72xx/7KG76xx/7KG77xx)	
Deviation	150 ppm
Display (7KG75xx / 7KG76xx)	high-resolution graphic display
Resolution	120 x 240 pixel
Dimensions	103 x 60 mm
Background illumination	yellow-green
Communication interface	
Interface	
Termination system	9-pin SUB D connector
Transmission rate	12 Mbit/sec max. with PROFIBUS
Transmission protocols parameterizable	MODBUS RTU / ASCII RS485 internal PROFIBUS-DP V1.0 MODBUS RTU / ASCII
Ambient temperature	acc. to IEC 60688
Operating temperature range	0 °C to + 55 °C
Storage/transportation	
Temperature range	- 25 °C to + 70 °C
Climatic	EN 60721-3-3 rare easy dewfall
Utilization category	IR2 (environment)
Dielectric strength	
Acc. to IEC 60688	5 kV 1.2 / 50 μs

Unit design	
Housing construction 7KG7755	Housing for snap-on mounting on a 35 mm rail according to DIN EN 50022. SIMEAS P55: IP 41 94 x 94 x 93.6 mm (W x H x D)
Housing construction 7KG7500 and 7KG7600, 7KG7750	Panel-mounting housing according to DIN 43700. SIMEAS P600: IP 41 front (optional IP 54) 144 x 144 x 115.3 mm (W x H x D) SIMEAS P50: IP 41 (front), IP 65 (option) 96 x 96 x 76.5 mm (W x H x D)
Connector elements	Degree of protection IP 20 (terminals) Terminal for cable diameter 2.5 mm ² Terminal for cable diameter 2.5 mm ² Terminal for cable diameter 4.0 mm ² Terminal for cable diameter 2.5 mm ² 9-pin SUB-D connector
Auxiliary power	
Voltage inputs	
Current inputs	
Binary outputs	
RS485 bus interface	
Weight	
7KG760/ 7KG7610/7KG7660 with 4 I/O modules	SIMEAS P600: approx. 0.75 kg
7KG7750/7KG7755 with 1 I/O module	SIMEAS P50/P55: approx. 0.95 kg approx. 0.60 kg approx. 0.65 kg
Specification of analog/digital input and output modules	
	only for 7KG7610/7KG7660/7KG775x
Analog input module	
Rated input current	0 - 20 mA _{DC}
Output range	0 - 24 mA _{DC}
Input impedance	50 Ω ± 0.1 %
Power consumption at I_N 0 24 mA	2 x 29 mW
Accuracy	0.5 % of measuring range limit
Binary input module	
Max. input voltage	300 V _{DC}
Max. current at high level	53 mA
Current consumption at high level	1.8 mA
Low level	≤ 10 V
High level	≤ 19 V
Time lag between low-high, high-low	max. 3 ms
Analog output module	
Rated output current	0 - 20/4 - 20 mA _{DC}
Output range	0 - 24 mA _{DC}
Max. load impedance	250 Ω
Accuracy	typ. 0.2 %; max. 1.1 % of nominal
Binary output module	
Permissible voltage	230 V _{AC} /250 V _{DC}
Permissible current	100 mA
Permissible impulse current	300 mA for 100 ms
Output resistance	50 Ω
Triggering current	5 mA
Triggering power	25 mW
Permissible switching frequency	10 Hz
Relay module	
Permissible voltage	270 V _{AC} /120 V _{DC}
Permissible current	5 A
Min. current	1 mA at 5 V _{DC}
Permissible power	5 A/250 V _{AC} or 5 A/30 V _{DC}
Output resistance	50 mΩ
Max. reaction time	10 ms
Max. drop-out time	7 ms

Selection and ordering data

Description	Order No.				
SIMEAS P600	7KG76□0-0□□0□-0□□0				
Extended built-in device for control panels 144 x 144 mm with graphic display, real-time module, battery and memory for recording of measured quantities	↑	↑	↑	↑	↑
Version					
without I/O modules	0	A	A	A	A
with I/O modules	1				
US without I/O modules (with UL-Listing and US-terminals)	5	A	A	A	A
US with I/O modules (with UL-Listing and US-terminals)	6				
I/O module in slot A					
Without		A			
2 binary outputs		B			
2 binary inputs		C			
2 analog outputs (0-20/4-20 mA _{DC})		D			
2 analog inputs (0-20 mA _{DC})		E			
3 relay outputs		G			
I/O module in slot B					
Without			A		
2 binary outputs			B	*)	
2 binary inputs			C		
2 analog outputs (0-20/4-20 mA _{DC})			D		
2 analog inputs (0-20 mA _{DC})			E		
Facia					
Degree of protection IP 41 (standard)				1	
Degree of protection IP 54				2	
I/O module in slot C					
Without					A
2 binary inputs					C
2 analog outputs (0-20/4-20 mA _{DC})					D
2 analog inputs (0-20 mA _{DC})					E
I/O module in slot D					
Without					A
2 binary inputs					C
2 analog outputs (0-20/4-20 mA _{DC})					D
2 analog inputs (0-20 mA _{DC})					E
Mounting kit for built-in devices on a 35 mm rail					7KG7052-8AA
For the devices SIMEAS P6xx-7KG76xx, an optional mounting kit for snap-on rail mounting on a 35 mm DIN rail acc. to DIN EN 50022 is available. This also enables mounting of 144 x 144 mm SIMEAS P devices with a display on a 35 mm rail.					

*) Only if position 9 ≠ G

Selection and ordering data

Description	Order No.
Power meter with display	
SIMEAS P50	7KG7750-0□A0□-0AA□
Build-in device for control panel 96 x 96 mm, standard protocols: PROFIBUS DP + MODBUS ¹⁾	
I/O module	
Without (standard)	A
2 binary outputs	B
2 binary inputs	C
2 analog outputs (0-20/4-20 mA _{DC})	D
2 analog inputs (0-20 mA _{DC})	E
3 relay outputs	G
Front protection class	
IP41 (standard)	1
IP65	3
Communication module	
RS485 with PROFIBUS DP and MODBUS RTU/ASCII	0
RS485 with IEC 60870-5-103 and MODBUS RTU/ASCII	1
Power meters without display	
SIMEAS P55	7KG7755-0□A00-0AA□
Snap-on rail mounting device 96 x 96 mm, protection class for front IP20, standard protocols: PROFIBUS + MODBUS	
I/O module	
Without (standard)	A
2 binary outputs	B
2 binary inputs	C
2 analog outputs (0-20/4-20 mA _{DC})	D
2 analog inputs (0-20 mA _{DC})	E
3 relay outputs	G
Communication module	
RS485 with PROFIBUS DP and MODBUS RTU/ASCII	0
RS485 with IEC 60870-5-103 and MODBUS RTU/ASCII	1
SIMEAS P configuration package	7KG7050-8A□
consisting of:	
<u>Software SIMEAS P PAR</u> for configuration, calibration of SIMEAS P units by means of a personal computer	
<u>Cable connector for connecting SIMEAS P to a PC</u> length 5 m incl. RS232/RS485 converter	
Connector:	
PC-side:	
9-pin SUB D connector, female	
SIMEAS P side:	
9-pin SUB D connector, male	
<u>Plug-in power supply unit for the converter</u>	
Power supply	
230 V AC / 50 Hz	A
120 V AC / 60 Hz	B

1) Firmware V.4 comprising MODBUS and IEC 60870-5-103 protocols
is available for download on the Internet at www.simeas.com

Dimension drawings in mm / inch

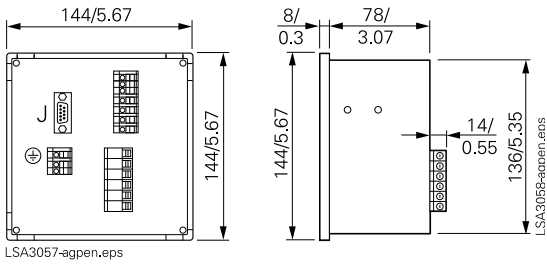

7KG7000 SIMEAS P

Fig. 17/44

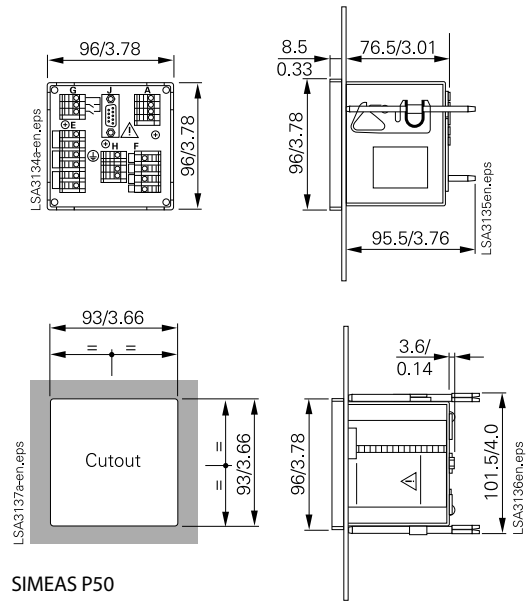

SIMEAS P50

Fig. 17/45

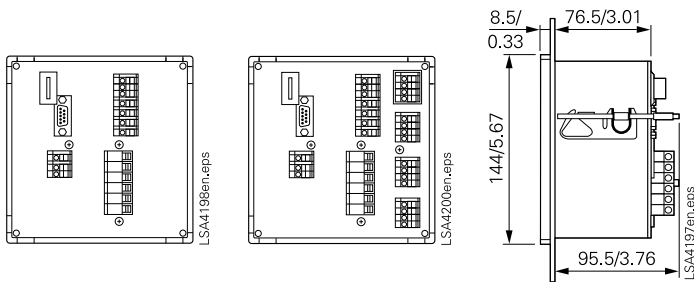

SIMEAS P600

SIMEAS P610

SIMEAS P600/P610

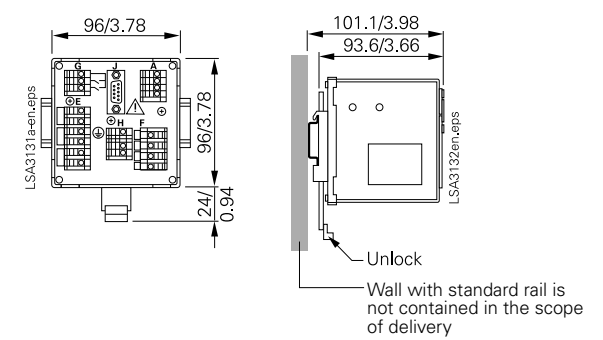

SIMEAS P55

Fig. 17/47

Attention:
Depending on the cable cross-section a minimal bend radius has to be considered.

Fig. 17/46

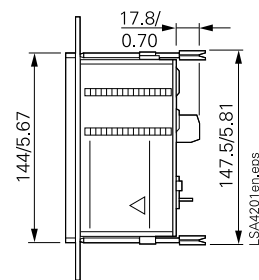

SIMEAS P600/P610

Dimension drawings in mm / inch

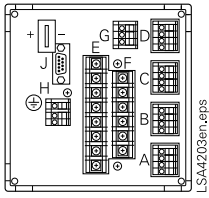

SIMEAS P660

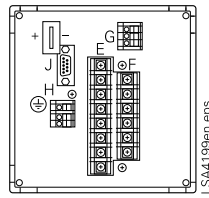

SIMEAS P650

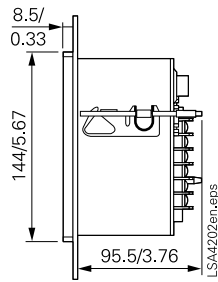

SIMEAS P650/P660

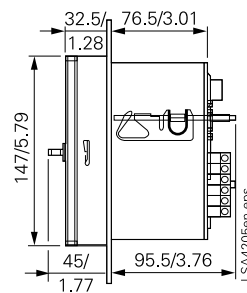

SIMEAS P6xx
with transparent plastic facia IP54
Fig. 17/49

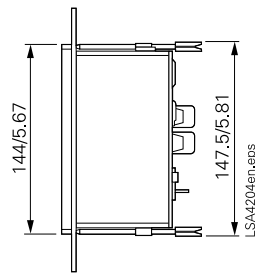
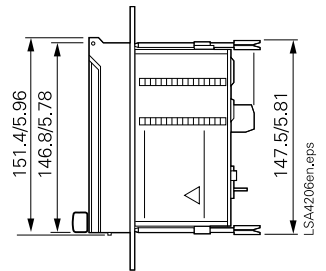

SIMEAS P650/P660

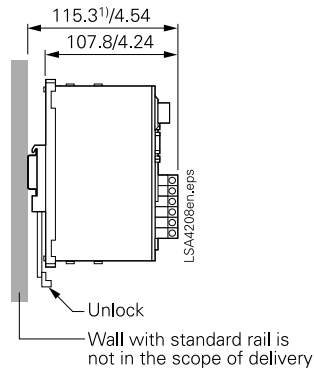
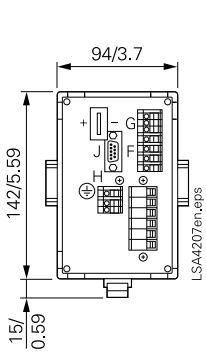

SIMEAS P100/P200

Fig. 17/50

- 1) Dimension illustration valid for standard rail according DIN EN 50022 - 35 x 7.5 mm

