

GSU 710/66

Double Sheet Testing Unit

en 04-2010/01 50108368



Dimensioned drawing

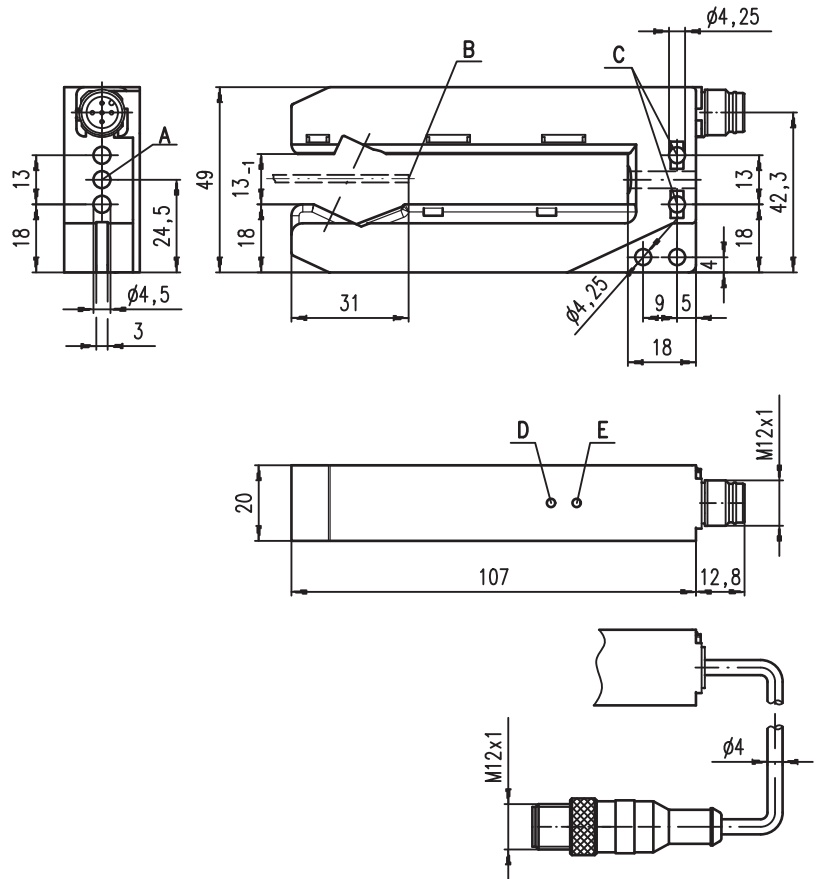

- A Through hole
- B Minimum intrusion depth of sheet edge
- C Inlay nut M4 possible
- D Red indicator diode
- E Yellow indicator diode

Electrical connection

GSU 710/66.4P-S12		
18-30V DC +	1	br/BN
Singlesheet	2	ws/WH
GND	3	bl/BU
Doublesheet	4	sw/BK
Teach in	5	gr/GY



18 - 30 V
DC

- Reliable detection of multi-layer paper and plastic sheets and metal foils
- Measurement range from 20g/m² paper to 800g/m² cardboard
- Plug connection
- Operating state indicators via light-emitting diodes
- Push-pull switching outputs

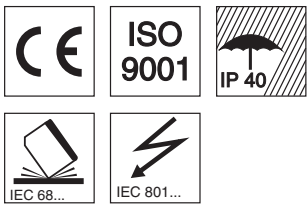

Accessories:

(available separately)

- M12 connectors (KD ...)
- Ready-made cables (K-D ...)

We reserve the right to make changes • DS_GSU_710_66_en.fm

Specifications

Physical data

Mouth width	13 mm
Mouth depth	89 mm
Minimum intrusion depth	31 mm
Converter frequency	approx. 330 kHz

Timing

Switching frequency	200 Hz
Response time	5 ms
Delay before start-up	≤ 300 ms acc. to IEC 60947-5-2

Electrical data

Operating voltage U_B	18 ... 30 VDC (incl. residual ripple)
Residual ripple	≤ 15% of U_B
Open-circuit current	≤ 50 mA
Switching outputs	2 push-pull switching outputs ¹⁾
Function characteristics	single sheet detected, or ≥ 1 sheet double sheet detected, or ≥ 2 sheets
Signal voltage high/low	≥ ($U_B - 2V$) / ≤ 2V
Output current	max. 100 mA per output

Indicators

Yellow LED	single sheet detected
Red LED	double sheet detected

Mechanical data

Housing	plastic
Color	red
Weight	approx. 100 g
Connection type	M12 connector, 5-pin, or cable 400 mm with M12 connector, 5-pin

Environmental data

Ambient temp. (operation/storage)	0 °C ... +50 °C / -40 °C ... +70 °C
Protective circuit ²⁾	1, 2, 3
VDE safety class	II, all-insulated
Protection class	IP 40
Standards applied	IEC 60947-5-2

Options

Teach-in input

Teach-in input resistance	R_{in} : 10 kΩ
Teach-in active/not active	.../...P (PNP): ≥ 10V / ≤ 2V or floating
Teach-in duration	max. 100 ms
Teach-in delay	approx. 300 ms

- 1) Function: .../...P = active high (+24V); not active low (0V)
The push-pull switching outputs must not be connected in parallel
- 2) 1=transient protection, 2=polarity reversal protection, 3=short circuit protection for all outputs

Mode of operation

The "singlesheet" output signals that an object is within the detection range. This output may be used to check for presence.

A detected double sheet is signaled at the "double sheet" output.

In the standard mode, 2-layer paper sheets with weights between approx. 40 g/m² and approx. 400 g/m² are detected without additional calibration.

With the "teach-in", the measurement range limits can be expanded to between approx. 20 g/m² and approx. 800 g/m².

The calibration process is started by applying a high signal at the "teach-in" input.

Calibration is performed either directly on a medium - if a sheet is in the detection range at the calibration time - or calibration is performed automatically if a medium is inserted into the detection range after the calibration time.

The calibration process is concluded after approx. 100 ms.

When switched back on, the sensor again functions in standard mode 40 g/m² ... 400 g/m².

Order guide

	Designation	Part No.
M12 connector	GSU 710/66.4P-S12	50108702
400 mm cable with M12 connector	GSU 710/66.4P, 400-S12	50112912

Remarks

- **Approved purpose:**
The GSU 710 double sheet testing unit is a monitoring unit predominantly designed for single sheet checking in paper processing machines. This product may only be used by qualified personnel and must only be used for the approved purpose. This sensor is not a safety sensor and is not to be used for the protection of persons.