

LSR 25B

Throughbeam photoelectric sensor

en 03-2011/09 50109622-01

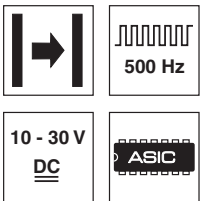

24m

- Throughbeam photoelectric sensor with visible red light
- High performance reserve
- Small and compact construction with robust plastic housing, protection class IP 66/IP 67 for industrial application
- Fast alignment through *brightVision*®
- Push-pull switching outputs
- High switching frequency for detection of fast events
- Warning output for increased availability
- Sensitivity adjustment
- Further options for adapting to the respective application
- Snap-locking connector for time-saving installation

We reserve the right to make changes • DS_LSR25B_4_66_a01_en.fm



Accessories:

(available separately)

- Mounting systems (BT 25, UMS 25...)
- Cable with M8 or M12 connector (K-D ...)
- Alignment aid (SAT 5)

Dimensioned drawing

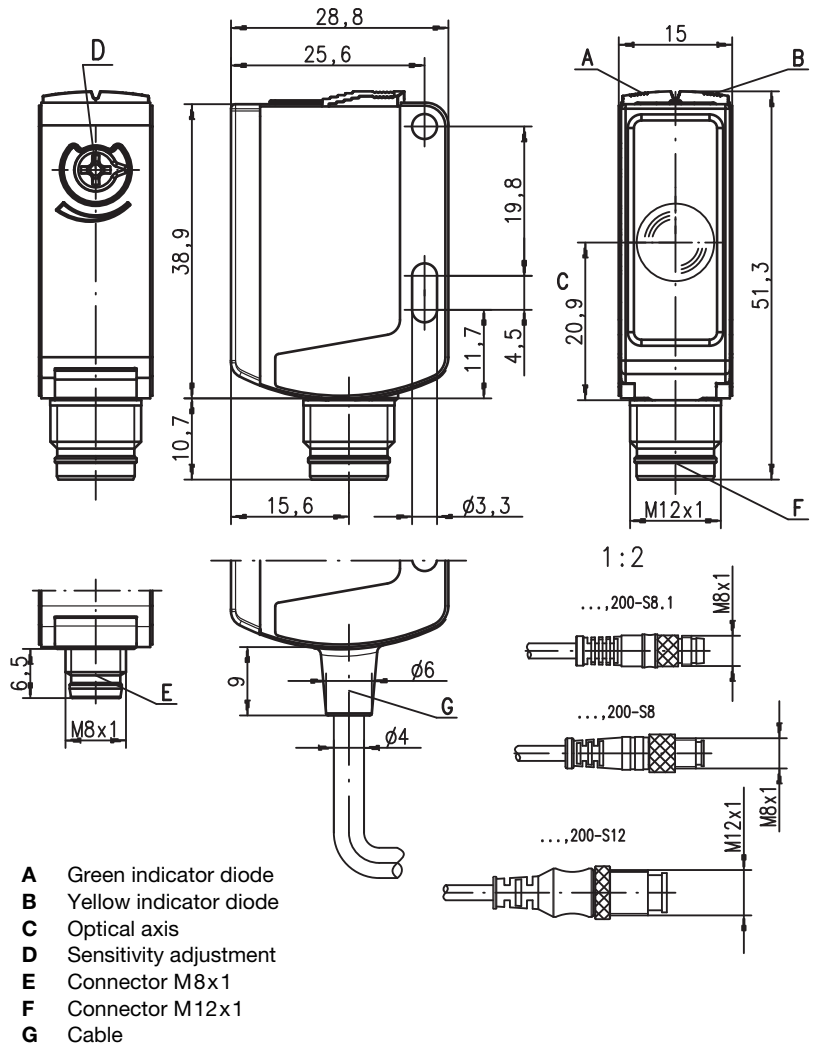

Electrical connection

Transmitter:

Receiver:

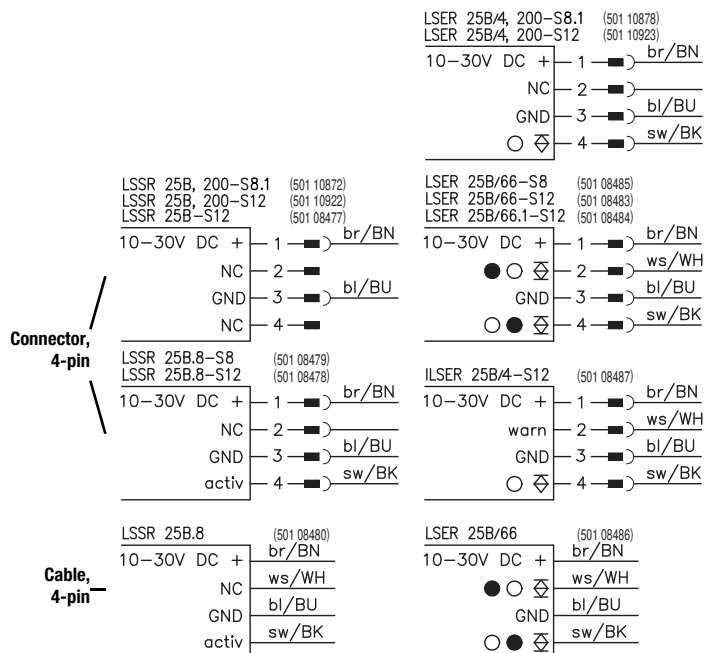

Specifications

Optical data

Typ. operating range limit ¹⁾	24 m
Operating range ²⁾	20 m
Light source ³⁾	LED (modulated light)
Wavelength	620nm (visible red light, polarised)

Timing

Switching frequency	500Hz
Response time	1 ms
Delay before start-up	≤ 300ms

Electrical data

Operating voltage U_B ⁴⁾	10 ... 30VDC (incl. residual ripple)
Residual ripple	≤ 15% of U_B
Open-circuit current	≤ 20mA
Switching output ⁵⁾	LSR .../66 LSR .../66.1 ILSR .../4 ILSR .../4.8 LSR .../4
	2 push-pull switching outputs pin 2: PNP dark switching, NPN light switching pin 4: PNP light switching, NPN dark switching
	1 warning output pin 2: PNP pin 4: PNP light-switching pin 4: PNP light switching, pin 2: NC ⁶⁾
Function characteristics	light/dark switching
Signal voltage high/low	$\geq (U_B - 2V) \leq 2V$
Output current	max. 100mA
Operating range	fixed setting, adjustable with potentiometer for ".1 types"

Indicators

Green LED	ready
Yellow LED	light path free
Yellow LED, flashing	light path free, no performance reserve

Mechanical data

Housing	plastic (PC-ABS)
Optics cover	plastic (PMMA)
Weight	with connector: 15g with 2m cable: 55g
Connection type	cable 2m (cross section 4x0.21 mm ²), M8 or M12 connector

Environmental data

Ambient temp. (operation/storage)	-35°C ... +55°C / -30°C ... +60°C
Protective circuit ⁷⁾	2, 3
VDE safety class ⁸⁾	II
Protection class	IP 66, IP 67
LED class	1 (acc. to EN 60825-1)
Standards applied	IEC 60947-5-2
Certifications	UL 508 ⁴⁾

Options

Warning output autoControl warn	PNP transistor, counting principle
Signal voltage high/low	$\geq (U_B - 2V) \leq 2V$
Output current	max. 100mA
Activation input active	
Transmitter active/not active	$\geq 8V \leq 2V$
Activation/disable delay	≤ 1 ms
Input resistance	10KΩ ± 10%

- 1) Typ. operating range limit: max. attainable range without performance reserve
- 2) Operating range: recommended range with performance reserve
- 3) Average life expectancy 100,000h at an ambient temperature of 25°C
- 4) For UL applications: for use in class 2 circuits according to NEC only
- 5) The push-pull switching outputs must not be connected in parallel
- 6) Pin 2: unassigned, hence especially suitable for the connection to AS-interface I/O coupling modules
- 7) 2=polarity reversal protection, 3=short-circuit protection for all transistor outputs
- 8) Rating voltage 50V

Tables

0	20	24
---	----	----

	Operating range [m]
	Typ. operating range limit [m]

Diagrams

Typ. response behaviour

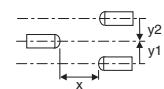
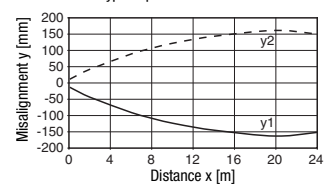

Typ. light spot

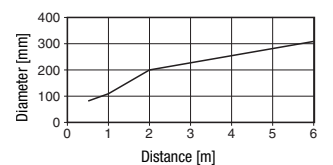

Remarks

A light axis consists of a transmitter and a receiver with the following designations:

- (I)LSR = complete light axis
- LSSR = transmitter
- (I)LSER = receiver

● Approved purpose:

This product may only be used by qualified personnel and must only be used for the approved purpose. This sensor is not a safety sensor and is not to be used for the protection of persons.

LSR 25B
Throughbeam photoelectric sensor
Order guide

Selection table		Order code →									
Equipment ↓		LSR 25B/66-S12 Part No. 50108477 (Tr) Part No. 50108483 (Re)	LSR 25B/66.8-S12 Part No. 50108478 (Tr) Part No. 50108483 (Re)	ILSR 25B/4-S12 Part No. 50108477 (Tr) Part No. 50108487 (Re)	ILSR 25B/4.8-S12 Part No. 50108478 (Tr) Part No. 50108487 (Re)	LSR 25B/66.1-S12 Part No. 50108477 (Tr) Part No. 50108484 (Re)	LSR 25B/66.8-S8 Part No. 50108479 (Tr) Part No. 50108488 (Re)	LSR 25B/66.8 Part No. 50108480 (Tr) Part No. 50108486 (Re)	LSR 25B/4, 200-S12 Part No. 50110922 (Tr) Part No. 50110923 (Re)	LSR 25B/4, 200-S8.1 Part No. 50110872 (Tr) Part No. 50110873 (Re)	
Switching output	2 x Push-pull switching output	●	●			●	●	●			
	1 x PNP output			●	●				●	●	
Switching function	PNP light switching and NPN dark switching output	●	●	●	●	●	●	●			
	PNP dark switching and NPN light switching output	●	●			●	●	●			
	1 x PNP light switching output								●	●	
	1 warning output, PNP light switching			●	●						
Connection	M8 connector, 4-pin						●				
	M12 connector, 4-pin	●	●	●	●	●					
	cable 2,000 mm							●			
	cable 200mm with M12 connector, 4-pin								●		
	cable 200mm with M8 connector, 4-pin ¹⁾									●	
Indicators	green LED: ready	●	●	●	●	●	●	●	●	●	
	yellow LED: light path free	●	●	●	●	●	●	●	●	●	
Options	sensitivity adjustment via potentiometer					●					
	activation input		●		●		●	●			
	high performance reserve	●	●	●	●	●	●	●	●	●	

1) Acc. to IEC 61076-2-101, NM construction with snap locking

