

ODSL 9

Optical laser distance sensors

en 02-2012/11 50115534

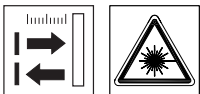

50 ... 650mm

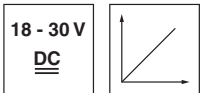

- Large measurement range
- Reflection-independent distance information
- Highly insensitive to extraneous light
- Measurement value is indicated in mm on LC display
- Configurable measurement mode
- Configurable measurement data preprocessing and filter
- Input (pin 2) for deactivating the laser, triggering, offset correction, reference measurement or teach-in
- M12 turning connector

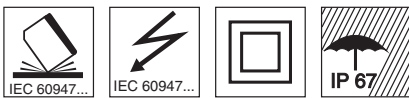

Accessories:

(available separately)

- Mounting systems
- Configuration software
- Cable with M12 connector (K-D ...)

Dimensioned drawing

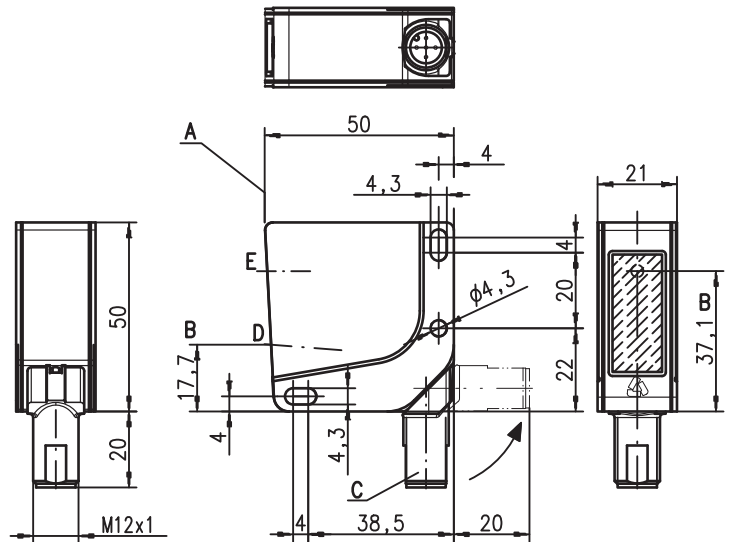

- A Reference edge for the measurement
- B Optical axis
- C Device plug M12
- D Receiver
- E Transmitter
- F LCD display
- G Indicator diode yellow
- H Indicator diode green
- J Control buttons

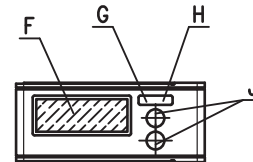

Electrical connection

ODSL 9/C6...

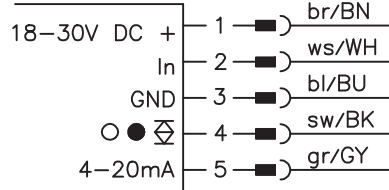

ODSL 9/V6...

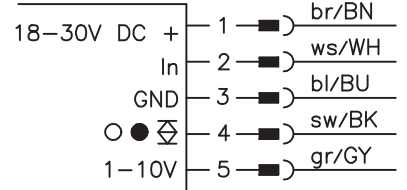

We reserve the right to make changes • DS_ODSL9650_en_50115534.fm

Specifications

Optical data

Measurement range ¹⁾	50 ... 650mm
Resolution ²⁾	0.1 ... 0.5mm
Light source	laser (red light, pulsed)
Wavelength	655nm
Max. output power	< 1.2mW
Pulse duration	22ms
Light spot	divergent, 1x1mm ² at 450mm

Error limits (relative to measurement distance)

Absolute measurement accuracy ¹⁾	± 1%
Repeatability ³⁾	± 0.5%
B/W detection thresh. (6 ... 90% rem.)	≤ 0.5%
Temperature compensation	yes ⁴⁾

Timing

Measurement time	2ms ¹⁾
Response time	≤ 6ms
Delay before start-up	≤ 300ms

Electrical data

Operating voltage U _B	...C6/V6	18 ... 30VDC (incl. residual ripple)
Residual ripple		≤ 15% of U _B
Open-circuit current		≤ 180mA
Switching output		push-pull switching output ⁵⁾ , PNP light switching, NPN dark switching
Signal voltage high/low		≥ (U _B -2 V)/≤ 2V
Analog output	...V6 ...C6	voltage 1 ... 10V / 0 ... 10V / 1 ... 5V / 0 ... 5V, R _L ≥ 2kΩ current 4 ... 20mA, R _L ≤ 500Ω

Indicators

Green LED	continuous light	ready	
	flashing	fault	teaching procedure
Yellow LED	off	no voltage	
	continuous light	object inside teach-in measurement distance	teaching procedure
	flashing	object outside teach-in measurement distance	
	off		

Mechanical data

Housing	plastic
Optics cover	glass
Weight	approx. 50g
Connection type	M12 connector, 5-pin

Environmental data

Ambient temp. (operation/storage)	-20°C ... +50°C / -30°C ... +70°C
Protective circuit ⁶⁾	1, 2, 3
VDE safety class ⁷⁾	II, all-insulated
Protection class	IP 67
Laser class	2 (according to EN 60825-1 and 21 CFR 1040.10 with Laser Notice No. 50)
Standards applied	IEC/EN 60947-5-2

- 1) Luminosity coefficient 6% ... 90%, complete measurement range, "Standard" operating mode, at 20°C, medium range of U_B, measurement object ≥ 50x50mm²
- 2) Minimum and maximum value depend on measurement distance
- 3) Same object, identical environmental conditions, measurement object ≥ 50x50mm²
- 4) Typ. ± 0.02 %/K
- 5) The push-pull switching outputs must not be connected in parallel
- 6) 1=transient protection, 2=polarity reversal protection, 3=short circuit protection for all outputs
- 7) Rating voltage 50VAC

Analog output: characteristic curve for factory setting

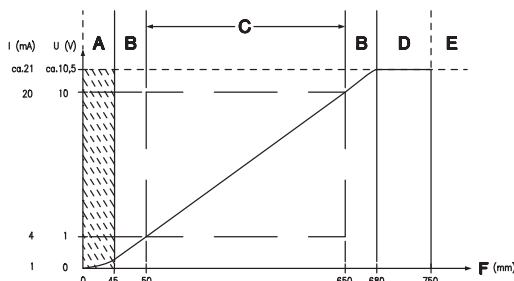

- A Area not defined
- B Linearity not defined
- C Measurement range
- D Object present
- E No object detected
- F Measurement distance

Order guide

	Designation	Part no.
Analog current output, 1 teachable push/pull output	ODSL 9/C6-650-S12	50113583
Analog voltage output, 1 teachable push/pull output	ODSL 9/V6-650-S12	50114627
ODSL 9/...650...- 02		

Tables

Diagrams

Remarks

- Measurement time depends on the reflectivity of the measurement object and on the measurement mode.
- **Approved purpose:**
This product may only be used by qualified personnel and must only be used for the approved purpose. This sensor is not a safety sensor and is not to be used for the protection of persons.