

**LS 318**

**Throughbeam photoelectric sensors**

**Dimensioned drawing**

LS. 318M/...

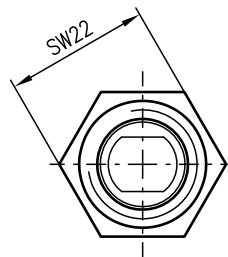
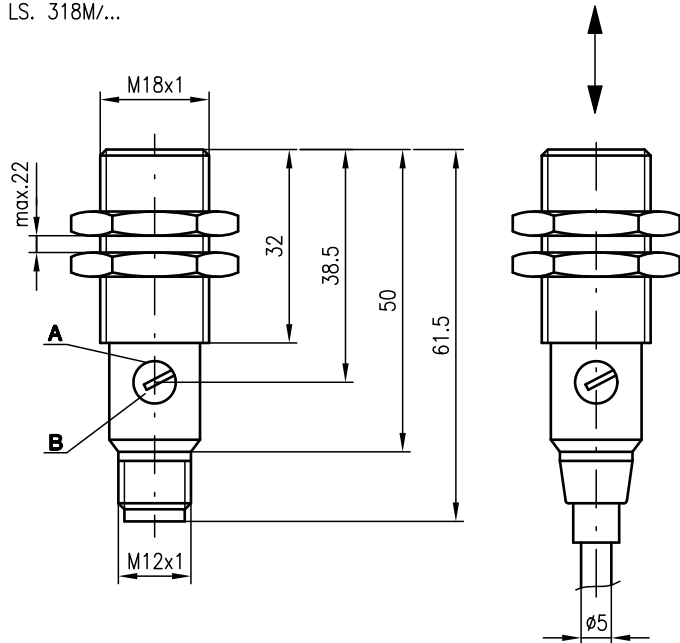

LS. 318K/...

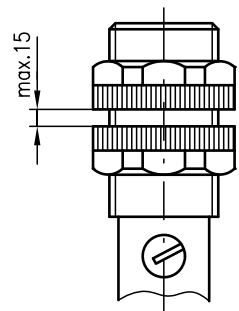

- A** Indicator diode
- B** Sensitivity adjustment

**Electrical connection**

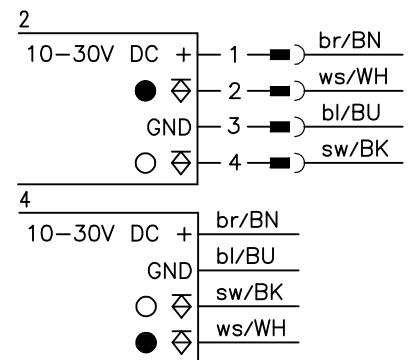
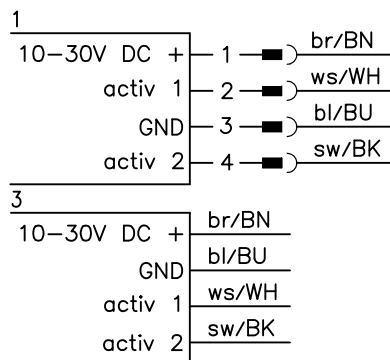

Part No. 501 08662



0 ... 20m  
0 ... 45m



- Throughbeam photoelectric sensors with long operating range in infrared light and straight optics
- Robust cylindrical stainless steel or plastic housing M18x1, protection class IP 67 for industrial application
- Activation input for testing and interlinking
- Complementary switching outputs for light/dark switching or as a control function
- Very short construction for application in limited spaces



**Accessories:**

(available separately)

- Mounting systems (BT 318, BT 318-ARH)
- M12 connectors (KD ...)
- Ready-made cables (K-D ...)

We reserve the right to make changes • 318\_a01gb.fm

## Specifications

### Optical data

Typ. operating range limit <sup>1)</sup>	0 ... 20m, 0 ... 45m
Operating range <sup>2)</sup>	0 ... 15m, 0 ... 35m
Light source	LED (modulated light)
Wavelength	880nm

### Timing

Switching frequency	1000Hz
Response time	0.5ms
Delay before start-up	≤ 30ms

### Electrical data

Operating voltage $U_B$	10 ... 30VDC
Residual ripple	≤ 10% of $U_B$
Bias current	≤ 25mA
Switching output	2 PNP transistor outputs, complementary
Function characteristics	light/dark switching
Signal voltage high/low	≥ ( $U_B - 1.6V$ ) ≤ 1.6V
Output current	max. 100mA
Sensitivity	adjustable

### Indicators

LED red	light path free
LED red flashing	light path free, no performance reserve

### Mechanical data

Housing	polyamide 12 or stainless steel
Optics cover	polyamide 12
Weight	90g (cable), 20g (M12)
Connection type	M12 connector, 4-pin cable 2m, 4x0.25mm <sup>2</sup>

### Environmental data

Ambient temp. (operation/storage)	-25°C ... +65°C/-40°C ... +70°C
Protective circuit <sup>3)</sup>	1, 2, 3, 4
VDE safety class <sup>4)</sup>	II, all-insulated
Protection class	IP 67
LED class	1 (acc. to EN 60825-1)
Standards applied	IEC 60947-5-2

### Options

<b>Activation input</b> activ 1	
Transmitter active/not active	≥ 8V or not connected/≤ 1.5V
<b>Activation input</b> activ 2	
Transmitter active/not active	≤ 1.5V or not connected/≥ 8V

- 1) Typ. operating range limit: max. attainable range without performance reserve
- 2) Operating range: recommended range with performance reserve
- 3) 1=transient protection, 2=polarity reversal protection, 3=short circuit protection for all outputs, 4=interference blanking
- 4) Rating voltage 250VAC

### Approved purpose:

The throughbeam photoelectric sensors are optical electronic sensors for optical, contactless detection of objects.

## Order guide

Selection table		Order code →								
		LS 318K/P-70-S12 Part No. 500 82195 (Tr) Part No. 500 81336 (Re)	LS 318K/P-S12 Part No. 500 81335 (Tr) Part No. 500 81336 (Re)	LS 318M/P-70-S12 Part No. 500 82177 (Tr) Part No. 500 81340 (Re)	LS 318M/P-S12 Part No. 500 81339 (Tr) Part No. 500 81340 (Re)	LS 318K/P-70 Part No. 500 82176 (Tr) Part No. 500 81338 (Re)	LS 318K/P Part No. 500 81337 (Tr) Part No. 500 81338 (Re)	LS 318M/P-70 Part No. 500 82188 (Tr) Part No. 500 81342 (Re)	LS 318M/P Part No. 500 81341 (Tr) Part No. 500 81342 (Re)	
Equipment ↓	Housing	plastic	●	●	●	●	●	●	●	●
		stainless steel			●	●			●	●
Connection	M12 connector	●	●	●	●			●		
	cable					●	●	●	●	
Switching output	PNP	●	●	●	●	●	●	●	●	
	NPN									●
Operating range	15m		●		●		●		●	
	35m	●		●		●		●		
Connection diagram	transmitter	1	1	1	1	3	3	3	3	
	receiver	2	2	2	2	4	4	4	4	

## Tables

### LS 318...-70-...

0	35	45
---	----	----

### LS 318...

0	15	20
---	----	----

Operating range [m]
Typ. operating range limit [m]

Model with integrated slit diaphragm for precise positioning tasks on request.

Slit diaphragm	Operating range
1.0mmx9mm	4.0m

## Diagrams

### LS 318...-70-...

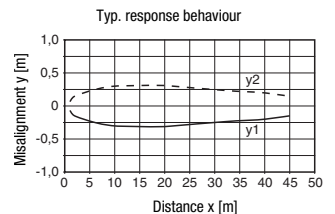

### LS 318...

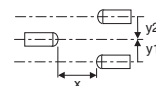
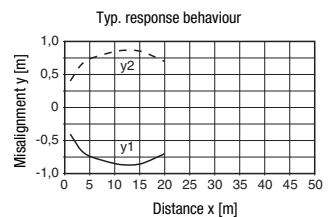

## Remarks

- For versions with NPN transistor output see separate data sheet.