

**ODSL 96B Ex d**

**Optical laser distance sensors**

en 04-2013/03 50108369-01



**Dimensioned drawing**

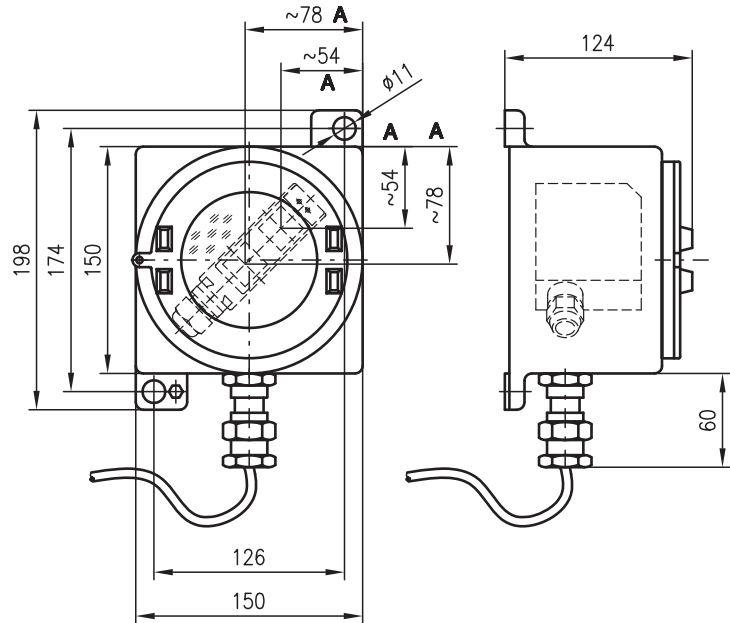

A Optical axis

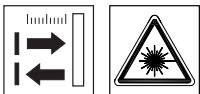

150 ... 2000mm

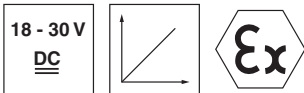

- Reflection-independent distance information
- Highly insensitive to extraneous light
- Analog current output
- Configurable measurement range and measure mode
- Configuration via PC/OLED display and key pad (the sensor must be removed from the Ex housing for this purpose)
- Teachable switching output and analog output
- EC type examination certificate KEMA 08 ATEX 0123
- Ex II 2G Ex d op is IIB+H<sub>2</sub> T4 Gb
- Ex II 2D Ex td A21 IP66 T135°C
- Cable 15m, 5-wire

**Electrical connection**

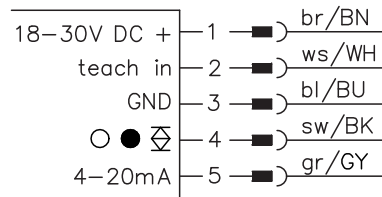

**Accessories:**

(available separately)

- Configuration software

We reserve the right to make changes • DS\_ODSL96BEx\_en\_50108369-01.fm

**Specifications**

**Optical data**

Measurement range <sup>1)</sup>	150 ... 2000mm
Resolution <sup>2)</sup>	1 ... 3mm
Light source	laser
Wavelength	655nm
Light spot	divergent, 2x6mm <sup>2</sup> at 2m
Max. output power	1.2mW
Pulse duration	22ms

**Error limits (relative to measurement distance)**

Absolute measurement accuracy <sup>1)</sup>	± 1,5 %
Repeatability <sup>3)</sup>	± 0,5 %
B/W detection thresh. (6 ... 90% rem.)	≤ 1 %
Temperature compensation	yes <sup>4)</sup>

**Timing**

Measurement time	1 ... 5 <sup>1)</sup> ms
Response time <sup>1)</sup>	≤ 15ms
Delay before start-up	≤ 300ms

**Electrical data**

Operating voltage U <sub>B</sub>	18 ... 30VDC (incl. residual ripple)
Residual ripple	≤ 15 % of U <sub>B</sub>
Open-circuit current	≤ 150mA
Switching output	push-pull switching output <sup>5)</sup> , PNP light switching, NPN dark switching
Signal voltage high/low	≥ (U <sub>B</sub> -2 V)/≤ 2V
Analog output	voltage 1 ... 10V, R <sub>i</sub> ≥ 2kΩ current 4 ... 20mA, R <sub>L</sub> ≤ 500Ω

**Indicators**

Green LED	continuous light flashing off
Yellow LED	continuous light flashing off

**Teach-in on GND**

ready	
fault	teach event
no voltage	
object inside teach-in measurement distance	teach event
object outside teach-in measurement distance	

**Teach-in on +U<sub>B</sub>**

**Mechanical data**

Housing	diecast zinc
Optics cover	glass
Weight	380g
Connection type	Cable 15m, 5-wire

**Metal housing**

**Environmental data**

Ambient temp. (operation/storage)	-20°C ... +50°C/-30°C ... +70°C
Protective circuit <sup>6)</sup>	1, 2, 3
VDE safety class <sup>7)</sup>	II, all-insulated
Protection class	IP 66, IP 67
Laser class	2 (in accordance with EN 60825-1)
Standards applied	IEC 60947-5-2

**Explosion protection**

Certification (CENELEC)	$\text{Ex}$ II 2G Ex d op is IIB+H <sub>2</sub> T4 Gb $\text{Ex}$ II 2D Ex td A21 IP66 T135°C
-------------------------	--

- 1) Luminosity coefficient 6% ... 90%, complete measurement range, at 20°C, medium range of U<sub>B</sub>, measurement object ≥ 50x50mm<sup>2</sup>
- 2) Minimum and maximum value depend on measurement distance
- 3) Same object, identical environmental conditions, measurement object ≥ 50x50mm<sup>2</sup>
- 4) Typ. ± 0.02 %/K
- 5) The push-pull switching outputs must not be connected in parallel
- 6) 1=transient protection, 2=polarity reversal protection, 3=short circuit protection for all outputs
- 7) Rating voltage 250VAC, with cover closed

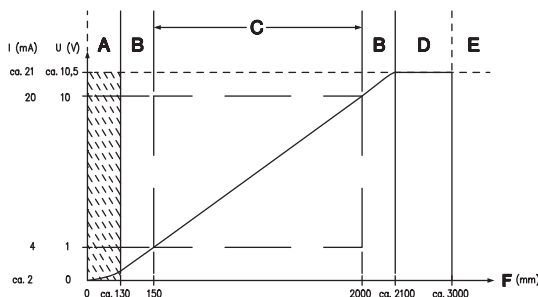

- A** Area not defined
- B** Linearity not defined
- C** Measurement range
- D** Object present
- E** No object detected
- F** Measurement distance

**Order guide**

	<b>Designation</b>	<b>Part no.</b>
<b>Cable connection, 15m</b>		
Current output	ODSL 96B M/C6-2000 Ex d	501 06735

**Tables**

**Diagrams**

**Remarks**

- Measurement time depends on the reflectivity of the measurement object and on the measurement mode.
- **Approved purpose:** This product may only be used by qualified personnel and must only be used for the approved purpose. This sensor is not a safety sensor and is not to be used for the protection of persons.

## Notices for the safe use of sensors in potentially explosive areas

### Intended application range

The distance sensors of the ODSL 96B Ex d series, without making contact, detect objects which are located in or move through the light beam and measure the distance to these objects.

### Validity

The sensors have an encapsulated, pressure-proof housing and can be used in the following areas with these classifications:

Device group	Device category	Equipment protection level	Zone
II	2G	Gb	Zone 1
II	2D	Db	Zone 21



#### Attention!

- Check whether the equipment classification corresponds to the requirements of the application.
- The devices are not suited for the protection of persons and may not be used for emergency shutdown purposes.
- A safe operation is only possible if the equipment is used properly and for its intended purpose.
- Electrical equipment may endanger humans and (where applicable) animal health, and may threaten the safety of goods if used incorrectly or under unfavorable conditions in potentially explosive areas.
- The applicable national regulations (e.g. EN 60079-14) for the configuration and installation of explosion-proof systems must be observed.

### Installation, Commissioning



#### Attention!

Electrical equipment may endanger humans and (where applicable) animal health, and may threaten the safety of goods if used incorrectly and under unfavorable conditions in potentially explosive areas.

A safe operation in potentially explosive areas is only possible if the equipment is used properly and for its intended purpose.

The distance sensors of type ODSL 96B Ex d must only be installed and maintained by trained electricians.

When installing the sensors in Ex zones 1 and 21, the connection cable must be connected in a connection space with increased safety Ex e, or outside the Ex area.

The housing must be connected to the protective conductor system at the marked external connection terminal. For this purpose, always use a cable lug and make the connection as shown in the diagram.

Fastening screw (A) is to be secured with a lock washer (B) to protect against loosening.

The respective applicable national regulations for the installation of electrical equipment in potentially explosive areas must be observed.

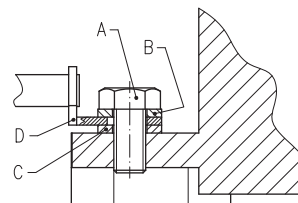

- A** Screw M6
- B** Lock washer
- C** Washer
- D** Cable lug

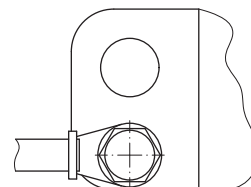

**Maintenance**

No changes may be made to the devices of type ODSL 96B Ex d for potentially explosive areas.

Repairs to the sensors may only be performed by persons trained for such work or by the manufacturer. Defective devices must be replaced immediately.

The housing must not be opened while the power is on! After switching off power, wait at least 10min. before opening the housing.

Cyclical maintenance of the sensors is not necessary.

Depending on the environmental conditions, it may occasionally be necessary to clean the light-emission surfaces of the sensors. This cleaning must only be performed by persons trained for performing this task. A soft, damp cloth should be used for this purpose. Cleaning agents that contain solvents must not be used.

**Chemical resistance**

The sensors of type ODSL 96B Ex d demonstrate good resistance against many diluted acids and bases.

Exposure to organic solvents is possible only under certain circumstances and only for short periods of time.

Resistance to chemicals should be examined on a case by case basis.

## Teach-in of switching outputs and characteristic output curve (Time Control, factory setting)

- Position the measured object at the desired distance.
- Activate the "**teach in**" input (pin 2) (with factory settings by applying  $+U_B$ ).

The duration of the activation of the teach input determines the teach step according to the table shown below. The teach event is indicated by the flashing of the LEDs and on the display.

Teach function	Duration of teach signal	Green LED	Yellow LED
Switching output Q1 Teach point	2 ... 4s	Flash synchronously	
Distance value for start of measurement range = 1V / 4mA at analogue output (pin 5)	4 ... 6s	Continuous light	Flash
Distance value for end of measurement range = 10V / 20mA at analogue output (pin 5)	6 ... 8s	Flash	Continuous light

At the end of the given teach event:

- Reconnect the teach input to GND.

A successful teach event is signaled by the end of the flashing of the LEDs.



### Notice

If the measurement range start is taught to a distance greater than the measurement range end, a declining characteristic output curve is automatically set.

### Error messages

Continuously flashing LEDs signal an unsuccessful teach event. The sensor remains ready for operation and continues to function with the old values.

Remedy:

- Repeat teach event **or**
- Activate teach input for more than 8s **or**
- Disconnect sensor from voltage to restore the old values.

**BARTEC**

**Erklärung der EG Konformität  
CE Declaration of Conformity  
Attestation de Conformité CE**

**BARTEC NEDERLAND b.v.  
Boelewerf 25  
NL 2987 VD RIDDERKERK**

Wir,

We,

Nous,

**BARTEC NEDERLAND b.v.**

erklären in alleiniger  
Verantwortung, daß  
das Produkt

declare under our sole  
responsibility that the  
product

attestons sous notre seule  
responsabilité que le  
produit



**CONTROL / DISTRIBUTION PANEL  
Type BARTEC C-COR-0V  
Serial number 3445910-10-1 and 3445910-10-2**

auf das sich diese  
Erklärung bezieht den  
Bestimmungen der  
folgenden Richtlinie  
entspricht

to which this declaration  
relates is in accordance  
with the provision of the  
following directive

se referent à cette  
attestation correspond aux  
dispositions des directive  
suvantes

**ATEX directive 94/9EC**

und mit folgenden  
Normen oder  
normativen Dokumenten  
übereinstimmt

and is in conformity with  
the following standards  
or other normative  
documents

et est conforme aux  
norms ou documents  
normatifs cidessous

**EN 60079-0: 2006  
EN 60079-1: 2007  
EN 60079-28: 2007**

**EN 61241-0: 2006  
EN 61241-1: 2004**

EG Baumuster  
Prüfbescheinigung

EC Type  
Examination Certificate

Attestation d'examen  
CE de type

**KEMA 08 ATEX 0123**

Benannte Stelle

Notified Body

Organisme Notifié

**DEKRA Certification B.V., Utrechtseweg 310, ARNHEM, NL**

Kennzeichnung

Marking

Marquage

**CE 0344**

**II 2G Ex d op is IIB+H<sub>2</sub> T4 Gb**

**II 2D Ex tD A21 IP66 T135°C**

Ridderkerk, February 1, 2012

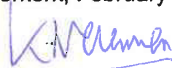

Dipl. Ing. Karel Neleman (B Eng)  
Technical manager / ATEX authorized

CE Declaration BARTEC-C