

CML 730i
Measuring light curtain

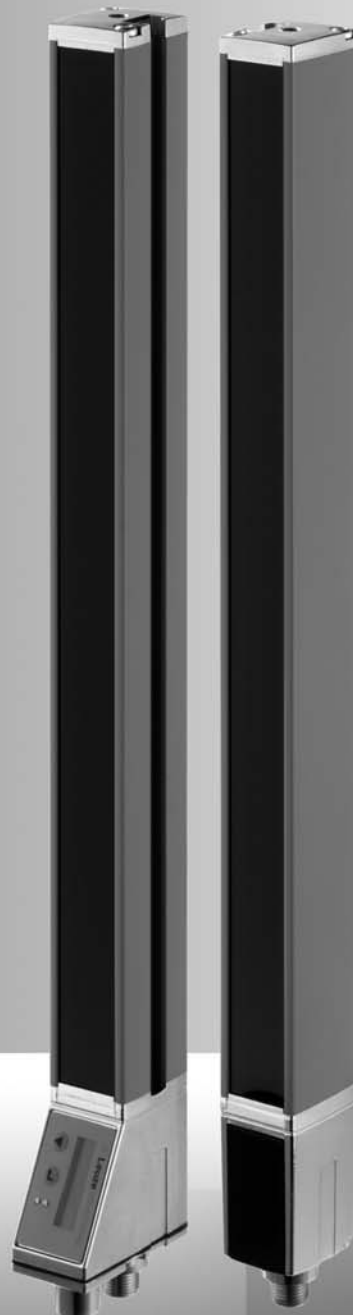

© 2013

Leuze electronic GmbH + Co. KG

In der Braike 1

D-73277 Owen / Germany

Phone: +49 7021 573-0

Fax: +49 7021 573-199

<http://www.leuze.com>

info@leuze.de

| | | |
|----------|---|-----------|
| 1 | About this document | 7 |
| 1.1 | Used symbols and signal words | 7 |
| 2 | Safety | 9 |
| 2.1 | Approved purpose and foreseeable improper operation | 9 |
| 2.1.1 | Proper use | 9 |
| 2.1.2 | Foreseeable misuse | 9 |
| 2.2 | Competent persons | 9 |
| 2.3 | Disclaimer | 10 |
| 3 | Device description | 11 |
| 3.1 | General information | 11 |
| 3.2 | General performance characteristics | 12 |
| 3.3 | Connection technology | 12 |
| 3.4 | Display elements | 12 |
| 3.4.1 | Operation indicators on the receiver control panel | 12 |
| 3.4.2 | Display on the receiver control panel | 13 |
| 3.4.3 | Operating indicators on the transmitter | 14 |
| 3.5 | Operating elements on the receiver control panel | 14 |
| 3.6 | Menu structure of the receiver control panel | 14 |
| 3.7 | Menu navigation on the receiver control panel | 16 |
| 3.7.1 | Meaning of the display icons | 16 |
| 3.7.2 | Level display | 17 |
| 3.7.3 | Menu navigation | 17 |
| 3.7.4 | Editing value parameters | 17 |
| 3.7.5 | Editing selection parameters | 19 |
| 4 | Functions | 20 |
| 4.1 | Operating modes | 20 |
| 4.1.1 | Parallel-beam scanning | 20 |
| 4.1.2 | Diagonal-beam scanning | 20 |
| 4.1.3 | Crossed-beam scanning | 21 |
| 4.2 | Measurement beam sequence | 22 |
| 4.3 | Beam stream | 23 |
| 4.4 | Evaluation functions | 23 |
| 4.5 | Hold function | 24 |
| 4.6 | Blanking | 24 |
| 4.6.1 | Auto blanking during teaching | 25 |
| 4.7 | Smoothing | 25 |
| 4.8 | Cascading/triggering | 27 |
| 4.8.1 | Cascading via external trigger | 28 |
| 4.8.2 | Cascading via internal trigger | 29 |
| 4.9 | Block evaluation of beam areas | 31 |
| 4.9.1 | Mapping of beam areas to switching outputs | 31 |
| 4.9.2 | Autosplitting | 33 |
| 4.10 | Switching outputs | 33 |
| 4.10.1 | Light / dark switching | 33 |
| 4.10.2 | Time functions | 33 |
| 4.11 | Interference suppression (filter depth) | 34 |
| 5 | Applications | 35 |
| 5.1 | Height measurement | 35 |
| 5.2 | Object measurement | 35 |

| | | |
|-----------|---|-----------|
| 5.3 | Width measurement, position detection | 36 |
| 5.4 | Contour measurement | 36 |
| 5.5 | Gap control/gap measurement | 37 |
| 5.6 | Hole recognition | 37 |
| 6 | Mounting and installation | 38 |
| 6.1 | Mounting the light curtain | 38 |
| 6.2 | Definition of directions of movement | 39 |
| 6.3 | Fastening via sliding blocks | 40 |
| 6.4 | Fastening via swivel mount | 40 |
| 6.4.1 | One-sided mounting on the machine table | 41 |
| 6.5 | Fastening via swiveling mounting brackets | 41 |
| 7 | Electrical connection | 42 |
| 7.1 | Connection cables | 42 |
| 7.2 | Device connections | 42 |
| 7.3 | Electrical connection of the system components for IO-Link devices and analog devices | 42 |
| 7.3.1 | X1 pin assignment for IO-Link devices (logic and power on the receiver) | 43 |
| 7.3.2 | X1 pin assignment for analog devices (logic and power on the receiver) | 44 |
| 7.3.3 | X2/X3 pin assignment for IO-Link devices/analog devices (receiver or transmitter) | 45 |
| 7.4 | Electrical connection of the system components for fieldbus devices | 46 |
| 7.4.1 | Pin assignment for fieldbus devices | 47 |
| 7.5 | Electrical supply | 49 |
| 8 | Starting up the device - Basic configuration | 50 |
| 8.1 | Aligning transmitter and receiver | 50 |
| 8.2 | Teaching the environmental conditions | 52 |
| 8.2.1 | - Teach via receiver control panel | 52 |
| 8.2.2 | Teaching via a control signal from the control | 54 |
| 8.3 | Check alignment | 55 |
| 8.4 | Extended configurations on the receiver control panel menu | 55 |
| 8.4.1 | Define digital inputs/outputs | 55 |
| 8.4.2 | Inversion of the switching behavior (light/dark switching) | 57 |
| 8.4.3 | Defining the filter depth | 58 |
| 8.4.4 | Defining the display properties | 58 |
| 8.4.5 | Changing the language | 59 |
| 8.4.6 | Product information | 59 |
| 8.4.7 | Resetting to factory settings | 59 |
| 9 | Starting up the device - Analog output | 61 |
| 9.1 | Analog output configuration on the receiver control panel | 61 |
| 9.2 | Analog output configuration via the IO-Link configuration interface | 61 |
| 9.3 | Behavior of the analog output | 62 |
| 10 | Starting up the device - IO-Link interface | 65 |
| 10.1 | Defining I/O-Link device configurations on the receiver control panel | 65 |
| 10.2 | Configurations on the IO-Link master module of the PLC | 65 |
| 10.3 | Parameter/process data for IO-Link | 66 |
| 11 | Starting up the device - CANopen fieldbus interface | 79 |
| 11.1 | Defining the CANopen basic configuration on the receiver control panel | 79 |
| 11.2 | Configurations with the fieldbus-specific software | 79 |
| 11.3 | Parameter/process data for CANopen | 80 |

| | | |
|-----------|---|------------|
| 12 | Starting up the device - Profibus fieldbus interface | 94 |
| 12.1 | Defining the Profibus basic configuration on the receiver control panel | 94 |
| 12.2 | Configurations with the fieldbus-specific software | 95 |
| 12.3 | Parameter/process data for Profibus | 95 |
| 12.3.1 | General information on Profibus | 95 |
| 12.4 | Parameter/process data for Profibus | 96 |
| 13 | Example configurations | 104 |
| 13.1 | Example configurations for reading out 64 beams (beam stream) | 104 |
| 13.1.1 | Configuration of beam-stream process data via IO-Link interface | 104 |
| 13.1.2 | Configuration of beam-stream process data via CANopen interface | 104 |
| 13.1.3 | Configuration of beam-stream process data via Profibus interface | 104 |
| 13.2 | Example configuration: mapping of beams 1 to 32 to output pin 2 | 104 |
| 13.2.1 | Configuration of area/output mapping (general) | 104 |
| 13.2.2 | Configuration of an area/output mapping via IO-Link interface | 105 |
| 13.2.3 | Configuration of area/output mapping via CANopen interface | 106 |
| 13.2.4 | Configuration of area/output mapping via Profibus interface | 106 |
| 13.3 | Example configuration - hole recognition | 106 |
| 13.3.1 | Configuration of hole recognition via IO-Link interface | 107 |
| 13.3.2 | Configuration of hole recognition via CANopen interface | 107 |
| 13.3.3 | Configuration of hole recognition via Profibus interface | 108 |
| 13.4 | Example configuration - activating and deactivating blanking areas | 108 |
| 13.4.1 | Configuration of blanking areas (general) | 108 |
| 13.4.2 | Configuration of blanking areas via IO-Link interface | 108 |
| 13.4.3 | Configuration of blanking areas via CANopen interface | 109 |
| 13.4.4 | Configuration of blanking areas via Profibus interface | 109 |
| 13.5 | Example configuration - configuration of a cascade arrangement | 110 |
| 13.5.1 | Configuration of a cascade arrangement (general) | 110 |
| 13.5.2 | Configuration of a cascading arrangement via IO-Link interface | 111 |
| 13.5.3 | Configuration of a cascading arrangement via CANopen interface | 112 |
| 13.5.4 | Configuration of a cascading arrangement via Profibus interface | 113 |
| 14 | Connection to a PC | 115 |
| 14.1 | Connection configuration | 115 |
| 14.2 | Installation requirements on the PC | 115 |
| 15 | Troubleshooting | 117 |
| 15.1 | What to do in case of failure? | 117 |
| 15.2 | Operating displays of the LEDs | 117 |
| 16 | Care, maintenance and disposal | 119 |
| 16.1 | Cleaning | 119 |
| 16.2 | Servicing | 119 |
| 16.2.1 | Firmware update | 119 |
| 16.3 | Disposing | 119 |
| 17 | Service and support | 120 |
| 18 | Specifications | 121 |
| 18.1 | General specifications | 121 |
| 18.2 | Timing | 124 |
| 18.2.1 | Limits for detecting objects | 125 |
| 18.3 | Dimensioned drawings | 127 |
| 18.4 | Dimensional drawings: accessories | 129 |

| | | |
|-----------|---|------------|
| 19 | Ordering information and accessories | 132 |
| 19.1 | Nomenclature | 132 |
| 19.2 | Accessories | 133 |
| 19.3 | Scope of delivery | 136 |
| 20 | EC Declaration of Conformity | 137 |

1 About this document

This technical description contains information regarding the proper use of the CML measuring light curtain series. They are included in the delivery contents.

1.1 Used symbols and signal words

Table 1.1: Warning symbols, signal words and symbols



| | |
|---|--|
|  | This symbol precedes text messages which must strictly be observed. Failure to comply with this information results in injuries to persons or damage to the equipment. |
| NOTICE | Signal word for property damage Indicates dangers that may result in property damage if the measures for danger avoidance are not followed. |
|  | Symbol for tips Text passages with this symbol provide you with further information. |
|  | Symbols for action steps Text passages with this symbol instruct you to perform actions. |

Table 1.2: Display of the receiver control panel



| | | |
|---|----------------------|--|
|  | Main Settings | Bold text Indicates that this field is currently selected and highlighted. You can apply other input options to this field. |
|  | Digital IOs | Normal text Indicates that this field is not currently selected. |

Table 1.3: Terms and abbreviations

| | |
|---|---|
| FB (F irst B eam) | First beam |
| FIB (F irst I nterrupted B eam) | First interrupted beam |
| FNIB (F irst N ot Interrupted B eam) | First uninterrupted beam |
| LB (L ast B eam) | Last beam |
| LIB (L ast I nterrupted B eam) | Last interrupted beam |
| LNIB (L ast N ot Interrupted B eam) | Last uninterrupted beam |
| TIB (T otal Interrupted B eams) | Number of all interrupted beams |
| TNIB (T otal N ot Interrupted B eams) | Number of all uninterrupted beams (TNIB = n - TIB) |
| n | Total number of beams |
| GUI (G raphical U ser I nterface) | Graphical user interface |
| PLC | Programmable logic control |
| Response time per beam | Length of time for the evaluation of a beam |
| Resolution | The minimum size of an object that can be reliably detected. With parallel-beam evaluation, the smallest object to be detected corresponds to the sum of beam spacing and optic diameter. |

| | |
|-----------------------|---|
| Delay before start-up | Duration between the switching on of the supply voltage and the start of operational readiness of the light curtain. |
| Performance reserve | The performance reserve corresponds to a signal reserve following a teach event. A high performance reserve corresponds to a high signal level that is resistant to soiling. |
| Meas. field length | Optical detection range between the first and last beam |
| Beam spacing | Center-to-center spacing between two beams |
| Cycle time | Sum of the response times of all beams of a light curtain plus the internal evaluation. Cycle time = number of beams x response time per beam + evaluation time |

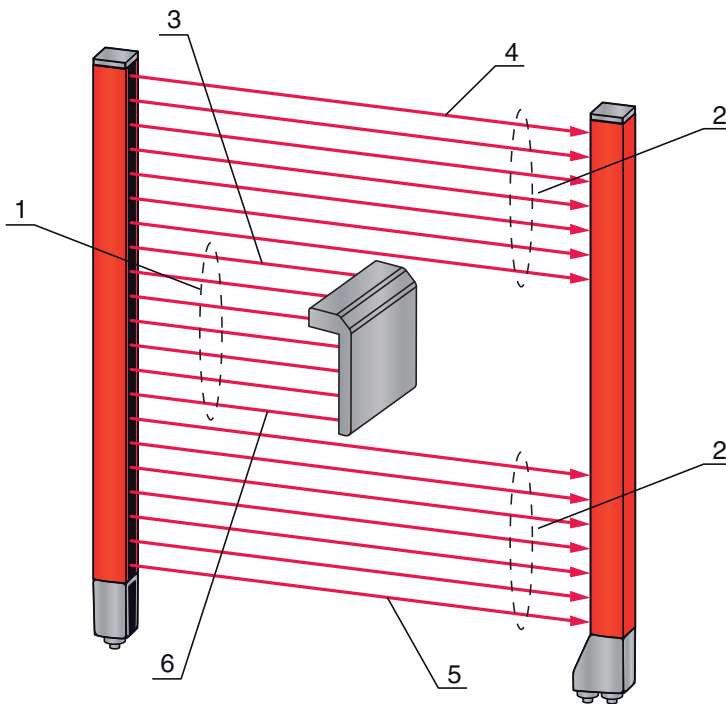

- 1 TIB (Number of all interrupted beams)
- 2 TNIB (Number of all uninterrupted beams)
- 3 LIB (Last interrupted beam)
- 4 LNIB (Last uninterrupted beam)
- 5 FNIB (First uninterrupted beam)
- 6 FIB (First interrupted beam)

Figure 1.1: Definition of terms

2 Safety

The CML measuring light curtain series was developed, manufactured and tested in accordance with the applicable safety standards. It corresponds to the state of the art.

2.1 Approved purpose and foreseeable improper operation

| |
|---|
|  CAUTION |
| <p>Must be observed!</p> <p>↳ The protection of personnel and the device cannot be guaranteed if the device is operated in a manner not complying with its intended use.</p> |

| |
|--|
| <p>NOTICE</p> |
| <p>Must be observed!</p> <p>↳ Access to or changes on the device, except where expressly described in this technical description, is not authorized.</p> <p>↳ Leuze electronic GmbH + Co. KG is not liable for damages caused by improper use.</p> <p>↳ Knowledge of this technical description is an element of proper use.</p> <p>↳ Observe the locally applicable legal regulations and the rules of the employer's liability insurance association.</p> |

2.1.1 Proper use

The measuring light curtain is designed as a measuring and object-detecting, configurable, multi-sensor unit.

Areas of application

The measuring light curtain is designed for the measurement and detection of objects for the following areas of application in handling and warehousing systems, the packaging industry or a comparable environment:

- Height measurement
- Width measurement
- Contour measurement
- Orientation detection.

2.1.2 Foreseeable misuse

Any use other than that defined under the "Approved purpose" or which goes beyond that use is considered improper use.

In particular, use of the measuring light curtain is not permitted in the following cases:

- Rooms with explosive atmospheres
- Operation for medical purposes

2.2 Competent persons

Prerequisites for competent persons:

- They have a suitable technical education.
- They are familiar with the rules and regulations for occupational safety and safety at work.
- They are familiar with the technical description of the measuring light curtain.
- They have been instructed by the responsible person on the mounting and operation of the measuring light curtain.

Electrical work must be carried out by a certified electrician.

2.3 Disclaimer

Leuze electronic GmbH + Co. KG is not liable in the following cases:

- the sensor is not being used properly
- reasonably foreseeable misuse is not taken into account
- mounting and electrical connection are not properly performed
- changes (e.g., constructional) are made to the sensor

3 Device description

3.1 General information

The light curtains of the CML series are designed as measuring and object-detecting, configurable, multi-sensor units. They monitor a measurement field and output measurement information from this field. Depending on the configuration and model, the devices are suitable for a variety of measurement tasks with various resolutions and can be integrated in different control environments.

The total system of the CML measuring light curtain consists of a transmitter and a receiver, including the connection cables.

- Transmitter and receiver are connected to one another via a synchronization cable.
- The integrated control panel with indicators and operational controls for configuring the total system is located on the receiver.
- The shared power supply is provided via connection X1 on the receiver.

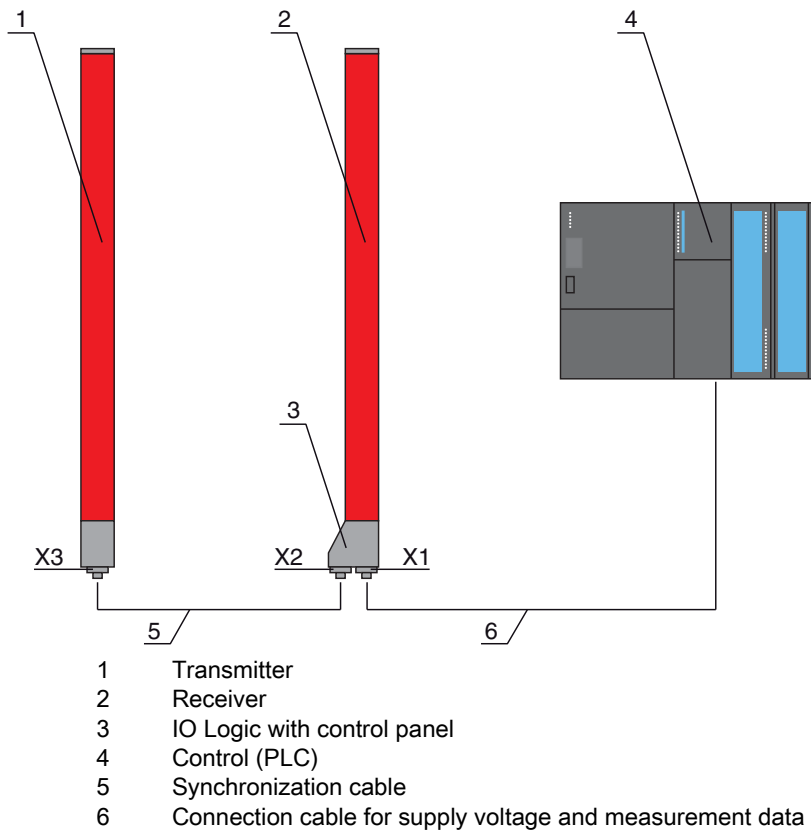

Figure 3.1: Principle architecture of the CML in combination with a programmable logic control

3.2 General performance characteristics

The most important performance characteristics of the CML 730i series are:

- Operating range up to 8000 mm
- Measurement field length from 150 mm to 2960 mm
- Beam spacings of 5 mm, 10 mm, 20 mm, 40 mm
- Response time 10 µs per beam
- Operating modes: parallel-beam / diagonal-beam / crossed-beam
- Single-beam evaluation (beam stream)
- Evaluation functions: TIB, TNIB, LIB, LNIB, FIB, FNIB, status of beam areas 1 ... 32, status of the digital inputs/outputs
- Up to four digital inputs/outputs (configurable)
- Local control panel with display
- Interfaces to the machine control: analog current/voltage output, IO-Link interface, CANopen, Profibus-DP
- Blanking of unnecessary beams
- Smoothing for interference suppression
- Cascading of multiple devices
- Block evaluation of beam areas
- Path functions
- Detection of transparent media

3.3 Connection technology

The transmitter and receiver feature an M12 connector with the following number of pins:

| Device type | Designation on device | Plug/socket |
|-------------|-----------------------|--------------------|
| Receiver | X1 | M12 plug (8-pin) |
| Receiver | X2 | M12 socket (5-pin) |
| Transmitter | X3 | M12 plug (5-pin) |

3.4 Display elements

The display elements are used for start-up and error analysis.

Located on the receiver is a control panel with the following display elements:

- two LEDs
- one OLED display, two-line

Located on the transmitter is the following display element:

- one LED

3.4.1 Operation indicators on the receiver control panel

Two function indicator LEDs are located on the receiver control panel.



- 1 LED1, green
- 2 LED2, yellow

Figure 3.2: LED indicators on the receiver

Table 3.1: Meaning of the LEDs on the receiver

| LED | Color | State | Description (in measurement operation) | Description (in alignment operation) |
|-----|--------|-----------------------|--|--------------------------------------|
| 1 | green | ON (continuous light) | Measuring light curtain ready (normal operation) | |
| | | flashing | Internal fault (see chapter 15.2 „Operating displays of the LEDs“) | Teach not successful |
| | | OFF | Sensor not ready | |
| 2 | yellow | ON (continuous light) | All active beams are free - with performance reserve | |
| | | flashing | Internal fault (see chapter 15.2 „Operating displays of the LEDs“) | Teach not successful |
| | | OFF | ≥ 1 beam interrupted (object detected) | |

3.4.2 Display on the receiver control panel

Located on the receiver is an OLED display which serves as a function indicator.



Figure 3.3: OLED display on the receiver

The type of display on the OLED display is different for the two following operating modes:

- Alignment operation
- Measurement operation

Display indicators in alignment operation

In alignment operation, the OLED display shows the received signal level of the first (FB) and last (LB) beam via two bar graph fields.

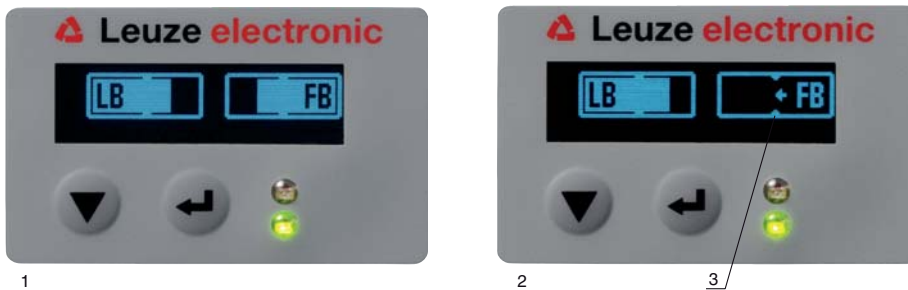

- 1 Optimally aligned light curtain
- 2 No reception signal from the first beam (FB); last beam optimally aligned
- 3 Marker for the minimum signal level which is to be achieved

Figure 3.4: OLED display on the receiver in alignment operation

Display indicators in measurement operation

In measurement operation, the upper line shows the number of interrupted beams (TIB) and the lower line shows the status of the inputs/outputs.

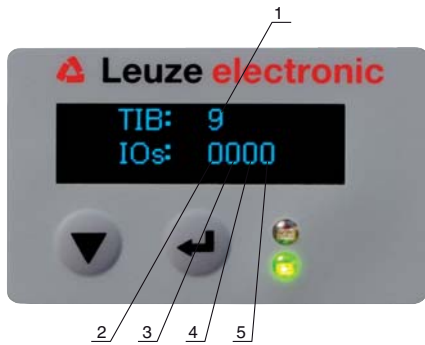

- 1 Number of interrupted beams
- 2 Logic state at pin 2 (0 = not active, 1 = active)
- 3 Logic state at pin 5 (0 = not active, 1 = active)
- 4 Logic state at pin 6 (0 = not active, 1 = active)
- 5 Logic state at pin 7 (0 = not active, 1 = active)

Figure 3.5: OLED display on the receiver in measurement operation



If the display is not actuated for several minutes, the display darkens and extinguishes. Press any button to again make the display visible. Settings for visibility, display duration, etc. can be changed via the Display menu.

3.4.3 Operating indicators on the transmitter

Located on the transmitter is an LED which serves as a function indicator.

Table 3.2: Meaning of the LED on the transmitter

| LED | Color | State | Description |
|-----|-------|--------------------------|---|
| 1 | green | ON (continuous light) | Measuring light curtain ready (normal operation) |
| | | OFF | No communication with the receiver |

3.5 Operating elements on the receiver control panel

Located on the receiver below the OLED display is a membrane keyboard with two function buttons for entering various functions (see chapter 3.7 „Menu navigation on the receiver control panel“).



Figure 3.6: Function buttons on the receiver

3.6 Menu structure of the receiver control panel

The following summary shows the structure of all menu items for all device models. In a given device model, only the actually available menu items are present for entering values or for selecting settings.

Menu level 0

Level 0

| |
|---------------|
| Main Settings |
| Digital IOs |
| Analog output |

Level 0

| |
|-------------|
| Display |
| Information |

Menu "Main Settings"

| Level 1 | Level 2 | Description |
|--------------|---------------|---|
| Mode | | Measurement operation |
| Command | | Teach Reset Factory Settings |
| Filter Depth | | (enter value) min = 1 max = 255 |
| IO-Link | Baud rate | COM3: 230.4 COM2: 38.4 |
| | PD Length | 32 bytes 8 bytes 2 bytes |
| CANopen | Node ID | (enter value) min = 1 max = 127 |
| | Baud rate | 1000 kBaud 500 kBaud 250 kBaud 125 kBaud |
| Profibus | Slave address | (enter value) min = 1 max = 126 |
| | Baud rate | 3 MBaud 1.5 MBaud 500 kBaud 187.5 kBaud 93.75 kBaud 45.45 kBaud 19.2 kBaud 9.6 kBaud |

Menu "Digital IOs"

| Level 1 | Level 2 | Description |
|----------|---------------|--|
| IO Logic | | Negative NPN Positive PNP |
| IO Pin 2 | | |
| IO pin 5 | IO-Direction | Output Input |
| IO Pin 6 | Inversion | Normal Inverted |
| IO Pin 7 | Input-funct. | Off Trigger In Teach In |
| | Output-funct. | Off Area Out Warn Out Trigger Out |
| | Area Logic | AND OR |
| | Start Beam | (enter value) min = 1 max = 1776 |
| | End Beam | (enter value) min = 1 max = 1776 |

Menu "Analog output"

| Level 1 | Level 2 | Description |
|-----------------|---------|---|
| Analog signal | | Off U: 0 ... 5 V U: 0 ... 10 V U: 0 ... 11 V I: 4 ... 20 mA I: 0 ... 20 mA I: 0 ... 24 mA |
| Analog function | | Off FIB FNIB LIB LNIB TIB TNIB |
| Start Beam | | (enter value) min = 1 max = 1776 |
| End Beam | | (enter value) min = 1 max = 1776 |

Menu “Display”

| Level 1 | Level 2 | Description |
|---------------|---------|--|
| Language | | English German |
| Visibility | | Off Dark Normal Bright Dynamic |
| Time Unit (s) | | (enter value) min = 1 max = 240 |





Menu “Information”



| Level 1 | Level 2 | Description |
|-------------------|---------|---|
| Product name | | CML 730i |
| Product ID | | Receiver part no. (e.g., 50119835) |
| Serial number | | Receiver serial number (e.g., 120950648) |
| Tx.transmitter-ID | | Transmitter part no. (e.g., 50119407) |
| Tx.transmitter-SN | | Transmitter serial number (e.g., 120950650) |
| SW version | | E.g., 01.61 |
| HW version | | E.g., A001 |
| Kx version | | E.g., P01.30e |

3.7 Menu navigation on the receiver control panel

The ▼ and ← buttons have different functions depending on the operating situation. These functions are displayed at the left edge of the display above the icons.



3.7.1 Meaning of the display icons

| Icon | Position | Function |
|---|-------------|---|
|  | First line | Symbolizes that you can select the next parameter within a menu level by pressing the ▼ button on the second line. |
|  | First line | Symbolizes the next higher menu level in which you are not currently navigating (not highlighted). |
|  | Second line | Symbolizes the respective, next option level that you have not yet selected (not highlighted). |
|  | Second line | Press the ← button to exit the menu level or the menu. Symbolizes a field that you can read but not change (e.g., in the “Information” menu). |
|  | Second line | Symbolizes the input mode. The selected (highlighted) option field can be a fixed selection parameter or a multi-digit input field. With a multi-digit input field, you can use the ▼ button to increase a counter and use the ← button to switch from one decimal place to the next. |



| Icon | Position | Function |
|---|-------------|--|
|  | Second line | Symbolizes the confirmation of a selection. This icon appears when you complete an option field with the ↵ button. |
|  | Second line | Symbolizes the rejection of a selection. This icon is accessed from the previous icon (check mark) by pressing the ▼ button. This mode allows you to reject the current value or option parameter by pressing the ↵ button. |
|  | Second line | Symbolizes the return to the selection. This icon is accessed from the previous icon (check mark) by pressing the ▼ button. This mode allows you to reset the current value or option parameter for the purpose of entering a new value or selecting an option parameter by pressing the ↵ button. |

3.7.2 Level display

The display of bars between icons and text that span both lines indicates the open menu levels. The number of bars indicates the current level in the menu hierarchy.



| | | | |
|--|--|--|-------------------|
|  | | | Start Beam |
|  | | | End Beam |

3.7.3 Menu navigation



| | |
|---|----------------------|
|  | Main Settings |
|  | Digital IOs |

- ▼ Selects the next menu item (“Digital IOs”) and, appearing if pressed again:
 - Analog output
 - Display
 - Information
 - Exit
- ↵ Selects the highlighted submenu (“Main Settings”).

3.7.4 Editing value parameters



| | |
|---|-------------------|
|  | Start Beam |
|  | End Beam |



- ▼ With each actuation, the next options on this operating level are displayed.
- ↵ Selects the “Start Beam” menu item with the bright background.

| | |
|---|------------|
|  | Start Beam |
|  | 0001 |



- ▼ Changes the value of the first digit (0).
- ↵ Selects additional numbers for configuring values.

After entering the last number, the total value can be finally saved, rejected or reset.

| | |
|---|------------|
|  | Start Beam |
|  | 0010 |



- ▼ Changes the action mode; first  and then  appears on the second line.
- ↵ Saves the new value (0010).



If the selected option is not saved in the window above, but rather the  action mode is selected with the ▼ button, this means:

| | |
|---|------------|
|  | Start Beam |
|  | 0010 |



- ▼ Changes the action mode;  appears on the second line.
- ↵ Rejects the current input value.

If the  action mode is selected with the ▼ button, this means:



| | |
|---|------------|
|  | Start Beam |
|  | 0010 |

- ▼ Changes the action mode;  appears; subsequent actuation displays  or  again.
- ↶ Resets the current input value (0001) and allows the entry of new values.



3.7.5 Editing selection parameters



| | |
|---|----------|
|  | IO Logic |
|  | IO Pin 2 |

- ▼ With each actuation, the next options on this operating level are displayed.
- ↶ Selects the “IO Logic” menu item with the bright background.

| | |
|---|--------------|
|  | IO Logic |
|  | Positive PNP |

- ▼ With each actuation, displays the next option on this menu level, i.e., the display switches between:
 - Negative NPN
 - Positive PNP
- ↶ Selects the “Positive PNP” menu item with the bright background.

| | |
|---|--------------|
|  | IO Logic |
|  | Positive PNP |

- ▼ Changes the action mode;  appears; subsequent actuation displays  or  again.
- ↶ Saves the selected option “Positive PNP”.

4 Functions

This chapter describes fundamental and extended functions for adaptation to the respective application conditions and requirements.

4.1 Operating modes

4.1.1 Parallel-beam scanning

In parallel-beam operation, the light beam of each transmitter LED is detected by the directly opposing receiver diode.

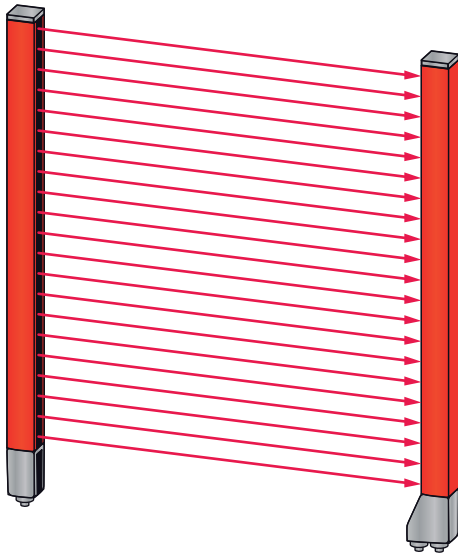
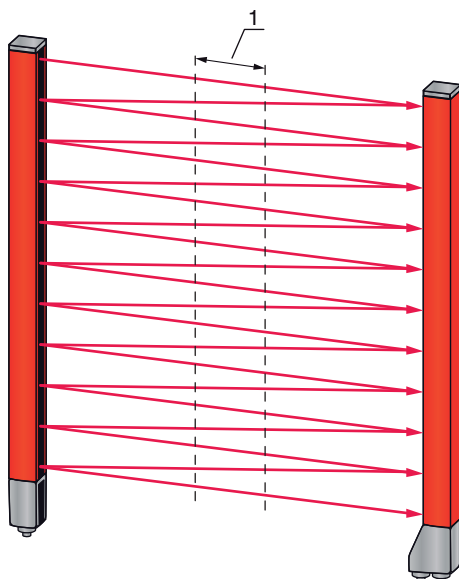

Figure 4.1: Beam path in parallel-beam scanning mode

4.1.2 Diagonal-beam scanning

In diagonal-beam operation, the light beam of each transmitter LED is detected alternately by both the directly opposing receiver LED as well as by the receiver LED (n-1) adjacent to it (diagonal-beam path). This doubles the resolution in the middle between the transmitter and receiver.



1 Area with increased resolution

Figure 4.2: Beam path in diagonal-beam scanning mode

Calculation

The number of beams for diagonal-beam scanning n_d is calculated from the number of beams for parallel-beam scanning n_p .

Formula for calculating the number of beams for diagonal-beam scanning

$$n_d = 2n_p - 1$$

- n_d [number] = number of beams for diagonal-beam scanning
- n_p [number] = number of beams for parallel-beam scanning

Example: through the measurement configuration, 288 actual beams (parallel-beam scanning) become 575 beams (diagonal-beam scanning). With a beam spacing of 5 mm, this spacing is reduced to 2.5 mm in the center area.



The diagonal-beam scanning function can be activated via the configuration software from Leuze electronic (see chapter 14 „Connection to a PC“) or via the respective fieldbus interface (see chapter 10 „Starting up the device - IO-Link interface“ ff.).

| |
|--|
| NOTICE |
| Minimum distance for diagonal-beam scanning! |
| ↪ For diagonal-beam scanning, a minimum distance between transmitter and receiver must be maintained, whereby the values vary depending on beam spacing (see chapter 18 „Specifications“). |

| |
|--|
| NOTICE |
| Teach after changing the operating mode! |
| ↪ Perform a teach after changing the operating mode (see chapter 8.2 „Teaching the environmental conditions“). |

4.1.3 Crossed-beam scanning

The crossed-beam scanning function is available for increasing the resolution for a larger area of the measurement field. In crossed-beam operation, each light beam of the transmitter LED is detected alternately by both the directly opposing receiver diode as well as by the receiver diodes (n+1, n-1) adjacent to it.

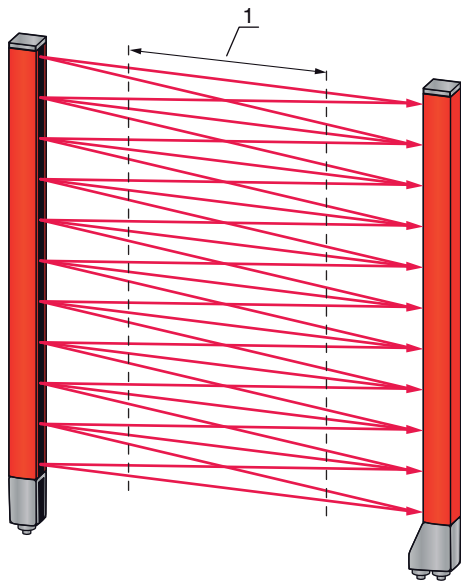

1 Area with increased resolution

Figure 4.3: Beam path in crossed-beam scanning mode

Calculation

The number of beams for crossed-beam scanning n_k is calculated from the number of beams for parallel-beam scanning n_p .

Formula for calculating the number of beams for crossed-beam scanning

$$n_k = 3n_p - 2$$

n_k [number] = number of beams for crossed-beam scanning
 n_p [number] = number of beams for parallel-beam scanning



The crossed-beam scanning function can be activated via the configuration software from Leuze electronic (see chapter 14 „Connection to a PC“) or via the respective fieldbus interface (see chapter 10 „Starting up the device - IO-Link interface“ ff.).

NOTICE

Minimum distance for crossed-beam scanning!

↪ For crossed-beam scanning, a minimum distance between transmitter and receiver must be maintained, whereby the values vary depending on beam spacing (see chapter 18 „Specifications“).

Example: through the measurement configuration, 288 actual beams (parallel-beam scanning) become 862 beams (crossed-beam scanning). With a beam spacing of 5 mm, this spacing is reduced to 2.5 mm in the center area.

NOTICE

Teach after changing the operating mode!

↪ Perform a teach after changing the operating mode (see chapter 8.2 „Teaching the environmental conditions“).

4.2 Measurement beam sequence

By default, the counting direction of the beams begins at the sensor connection unit. It can, however, be reconfigured so that counting again begins with 1 in the case of light curtain that is situated “back to front”. This simplifies handling if, e.g. two light curtains are arranged end-to-end in a cascading arrangement. The simplest application case for the inverted beam sequence is vertical mounting with the connection unit at the top, e.g., for height measurement, where beam 1 begins at the bottom, as shown below:

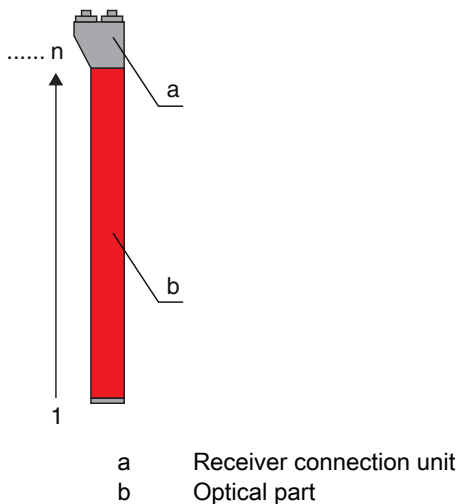

Another variant with two successive light curtains, where the second is arranged “back to front” and counting again begins with 1, is illustrated as follows:

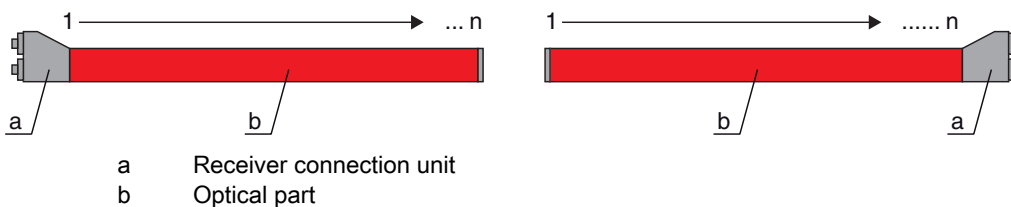

For width detection, counting begins on both ends with beam 1, as shown in the following:

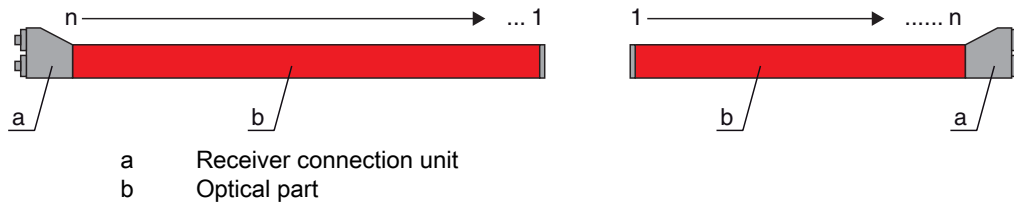

The counting direction can be changed via the configuration software from Leuze electronic (see chapter 14 „Connection to a PC“) or via the respective fieldbus interface (see chapter 10 „Starting up the device - IO-Link interface“ ff.).

NOTICE

Inverted evaluation function!

If the sequence is changed, the evaluation functions (FIB, LIB ...) are also inverted.

4.3 Beam stream

A beam stream refers to the output of each individual beam in serial sequence ((see figure 4.4)). Uninterrupted beams (free beams) are represented as logical 1 in the output bit in this case.



The data is available via the configuration software from Leuze electronic (see chapter 14 „Connection to a PC“) or via the respective fieldbus interface (see chapter 10 „Starting up the device - IO-Link interface“ ff.).

For an example configuration, see chapter 13.4.2 „Configuration of blanking areas via IO-Link interface“.

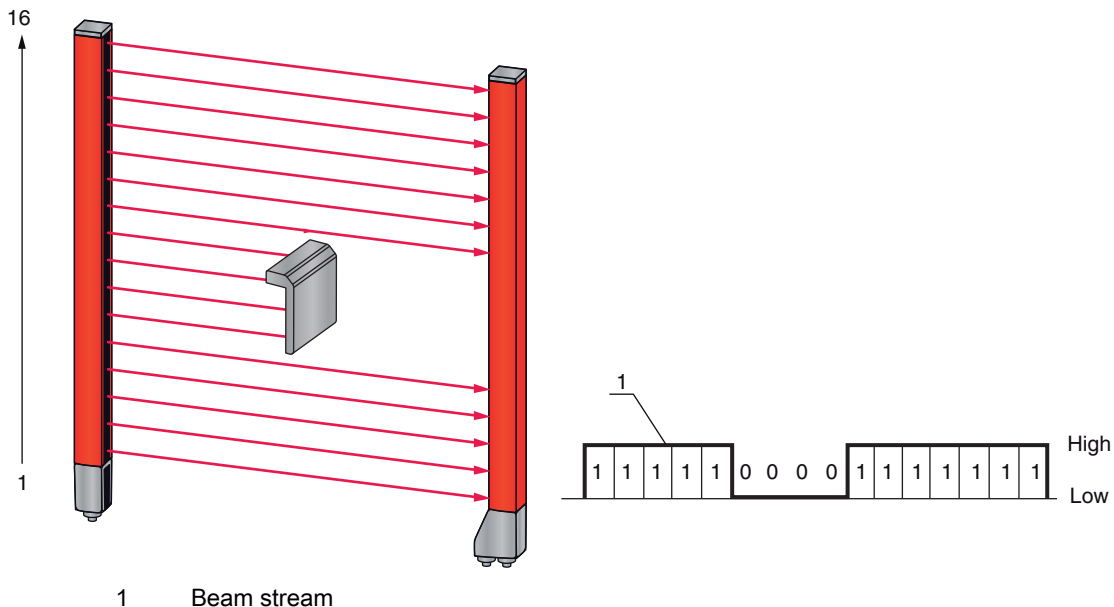

Figure 4.4: Illustration of a beam stream

4.4 Evaluation functions

The information on the individual beam states (free/interrupted) can be evaluated in the CML and the result read out via various evaluation functions.

The evaluation functions include the functions shown in the following figure:

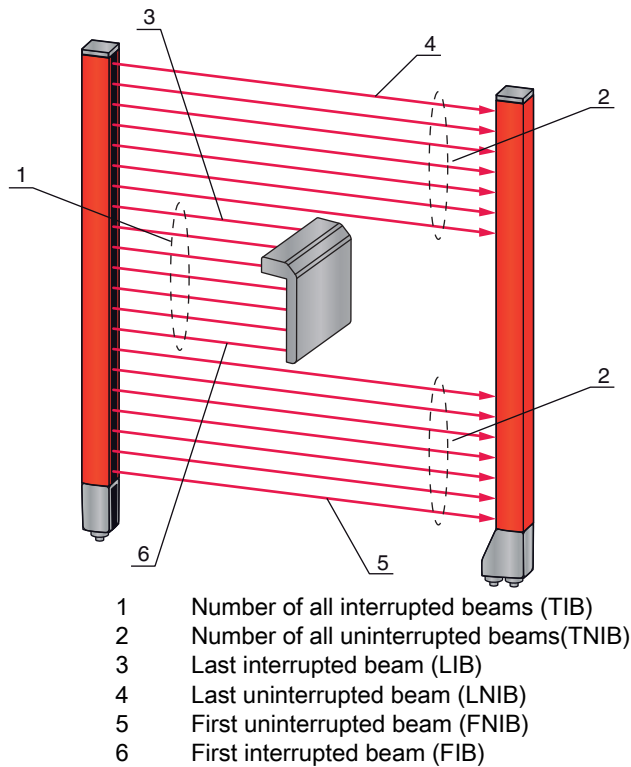

Figure 4.5: Evaluation functions

Also included among the evaluation functions are:

- the area mappings to an output pin (status of beam areas 1 ... 32), as well as
- the status of the digital inputs/outputs

For the area mappings to an output pin or the status of the digital inputs/outputs, see chapter 4.9 „Block evaluation of beam areas“.

4.5 Hold function

This function can be used to temporarily store the measurement value over the defined hold time until it is ensured by means of the primary control that the measurement data was read.



The setting for the hold times is made via a control command or telegram via the configuration software from Leuze electronic (see chapter 14 „Connection to a PC“) or via the respective field-bus interface (see chapter 10 „Starting up the device - IO-Link interface“ ff.).

Temporary storage of the beam data during the hold time means that the beam data maxima and minima are stored for the following evaluation functions:

- First interrupted beam (FIB)
- First uninterrupted beam (FNIB)
- Last interrupted beam (LIB)
- Last uninterrupted beam (LNIB)
- Number of all interrupted beams (TIB)
- Number of all uninterrupted beams(TNIB)

4.6 Blanking

During blanking, beams that are not to be included in the evaluation are suppressed. The numbering of the beams is not affected, i.e., the suppression of beams does not change the beam numbers.

If light curtains are installed such that existing frames / cross bars etc. continuously interrupt some beams, these beams must be suppressed.

 A maximum of four contiguous beam areas and a maximum of 50% of the existing beams can be suppressed.

 Beam suppression can be switched on and off via the configuration software from Leuze electronic (see chapter 14 „Connection to a PC“) or via the respective fieldbus interface (see chapter 10 „Starting up the device - IO-Link interface“ ff.).

For an example configuration, see chapter 13.4 „Example configuration - activating and deactivating blanking areas“.

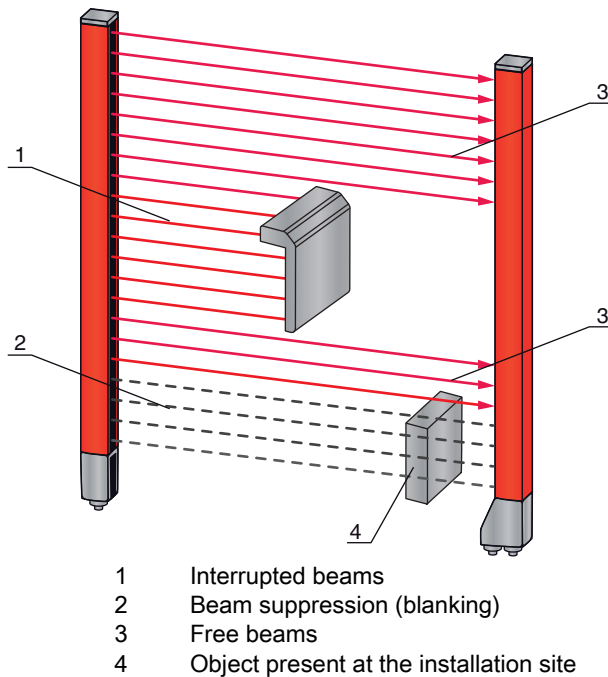

Figure 4.6: Beam states

| |
|--|
| NOTICE |
| Teach after changing the blanking configuration! |
| ↪ Perform a teach after changing the blanking configuration (see chapter 8.2 „Teaching the environmental conditions“). |

4.6.1 Auto blanking during teaching

If there are obstacles present in the measurement field at the installation site and at least one blanking area is activated, interrupted beams can be mapped to the blanking area(s) during teaching. Existing settings for the blanking areas are then overwritten (see chapter 8.2 „Teaching the environmental conditions“).

If no beams are interrupted during teaching, no blanking areas are configured.

| |
|---|
| NOTICE |
| Resetting all blanking areas! |
| ↪ To deactivate blanking, configure the “number of blanking areas” = 0. |
| ↪ A new teach must then be performed. |

4.7 Smoothing

With the smoothing function, interrupted beams are then only taken into account in the evaluation if the set minimum number of adjacent beams is reached. Individual interrupted beams that are not adjacent to one another do not result in beam evaluation.

Smoothing can be used, e.g., to suppress interference caused by spot soiling of the lens cover.

Smoothing "1" means that each object larger than a certain minimum size (dependent on beam spacing) is detected and measured.

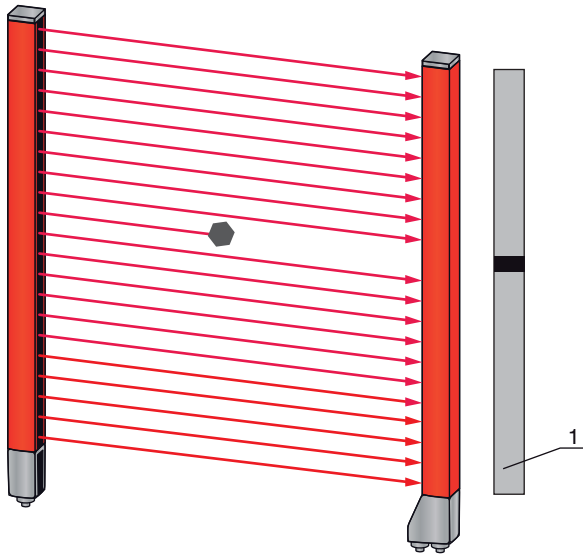

1 Data output: beam number x interrupted

Figure 4.7: Smoothing configuration "1"

If, for example, "2" is set, individual, non-adjacent, interrupted beams are ignored.

If smoothing is set to a value of "3", for example, data is only output if at least 3 adjacent beams are interrupted.

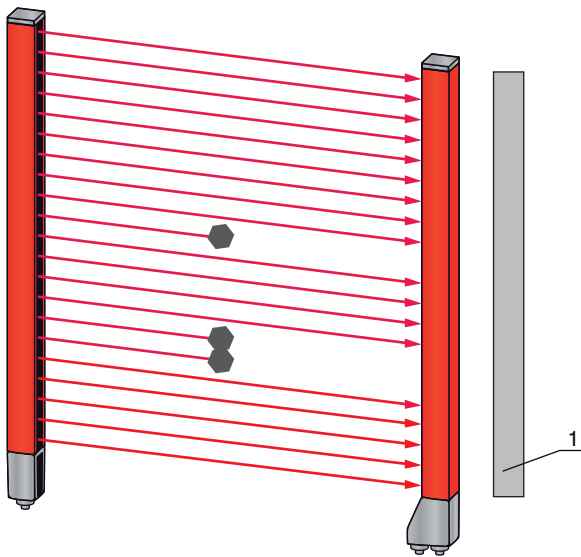

1 Data output: 0 beams interrupted

Figure 4.8: Smoothing configuration "3," but only maximum 2 beams interrupted

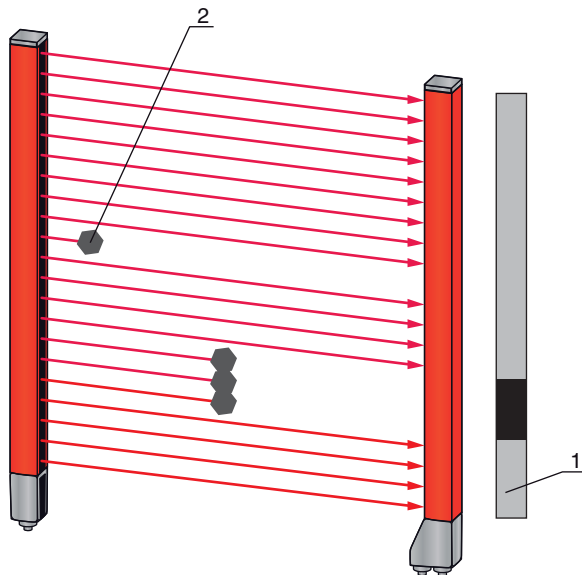

- 1 Data output: beam numbers from ... to ... interrupted
- 2 Interrupted beams are not taken into account

Figure 4.9: Smoothing configuration “3” and more than 3 adjacent beams interrupted

NOTICE

Configuration values for smoothing!

↪ Values from 1 to 255 can be entered for smoothing.

Inverted smoothing

This inverts the function, i.e., if there are uninterrupted (free) beams between the first interrupted beam (FIB) and the last interrupted beam (LIB), these are not output until the configured smoothing value is reached or exceeded.

By inverting the smoothing function, it is possible to detect, e.g., only successive openings of a certain minimum size within a web. In this way, it is possible to easily detect, e.g., defined punchings in a material web.

4.8 Cascading/trigging

If the measurement field length of a light curtain is not sufficient for detecting a desired measurement path, multiple light curtains can be connected in series or cascaded. When doing so, it must be ensured that the light curtains do not mutually influence or interfere with one another. This is ensured by activating (trigging) with a time offset. Nearly any number of light curtains with different numbers of beams can be cascaded so that they do not mutually interfere with one another.

The following light curtain arrangements are possible in a cascade arrangement:

- Multiple light curtains above one another, e.g., for a height measurement along a transport system

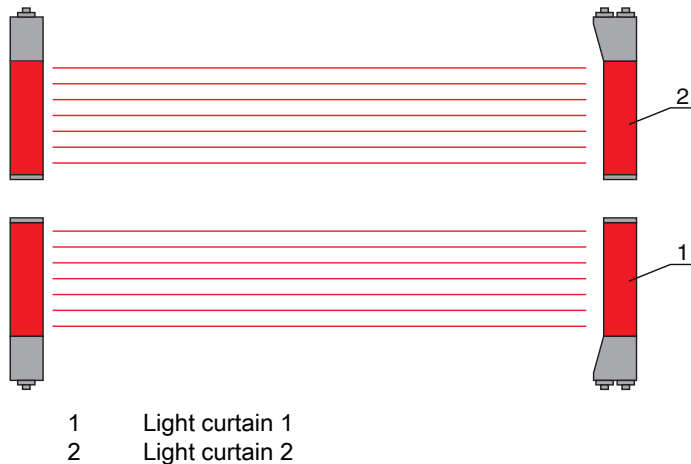

Figure 4.10: Simple cascading with two light curtains for height measurement

- Multiple light curtains in a rectangular frame, e.g., for object measurement of height and width along a transport system

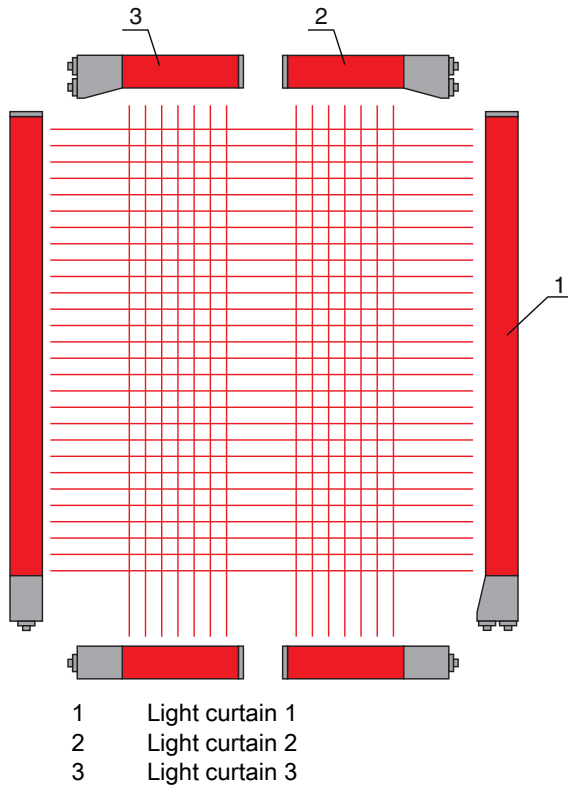

Figure 4.11: Simple cascading with three light curtains for object measurement

NOTICE

Cascading also necessary for multiple-track transport systems!

↪ Cascade light curtains for multiple-track transport systems.

Protection against mutual interference is realized through sequential activation of the light curtains.

4.8.1 Cascading via external trigger

Trigger In

Activation of the light curtain (or light curtains in the case of a cascaded arrangement) via the trigger input starts the measurement at a defined time in order to exclude mutual interference in the case of multiple light curtains in an application.

Arrangement for cascading via a trigger input

For an exact time assignment, it is possible to control the start of the measurement in a targeted manner. For external trigger activation, a trigger pulse generated in the PLC controls the start of the measurement. This trigger signal must be wired at all cascaded light curtains.



The selection of activation via an internal or external trigger signal is made via the configuration software from Leuze electronic (see chapter 14 „Connection to a PC“) or via the respective field-bus interface (see chapter 10 „Starting up the device - IO-Link interface“ ff.).

The individual light curtains are then configured in such a way that the respective measurement is performed with a time offset to the trigger ((see figure 4.12)).

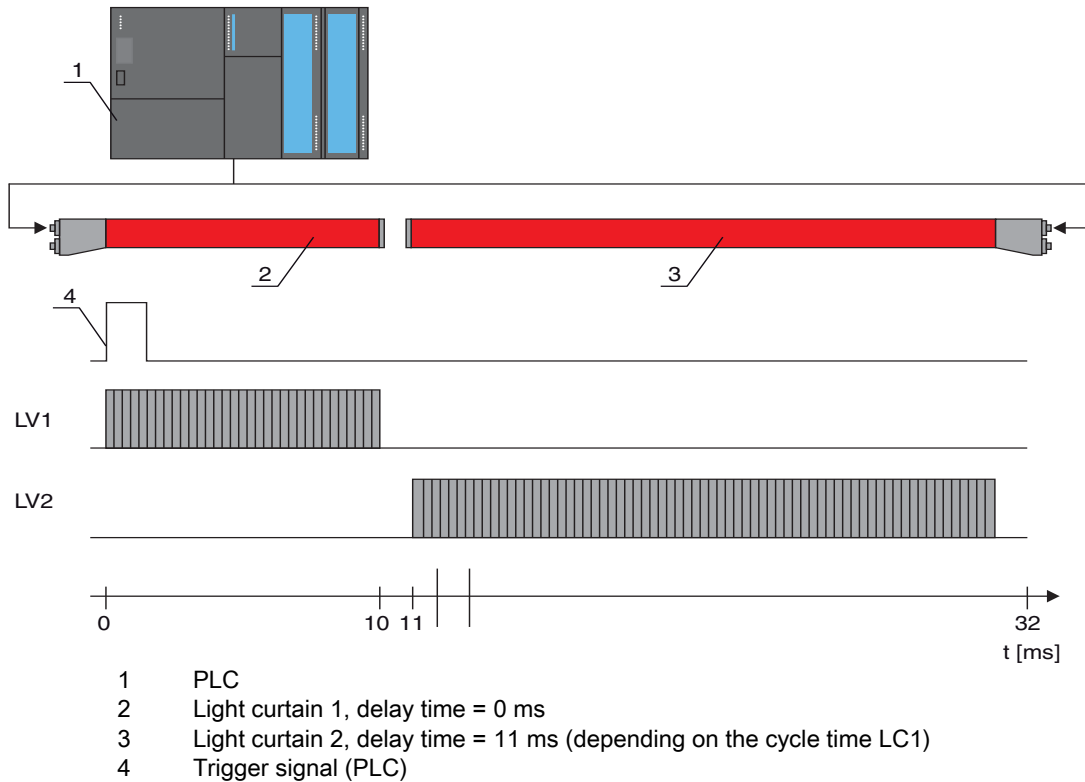

Figure 4.12: Cascading via external trigger

NOTICE

Simultaneous activation of multiple light curtains, if spatially separated!

↪ If the spatial configuration excludes mutual interference, multiple light curtains can also be activated simultaneously.

4.8.2 Cascading via internal trigger

Trigger Out

The trigger output of the CML makes the trigger signal necessary for “cascading via internal trigger” available at the master light curtain. The trigger output must be wired to the trigger inputs of the slave light curtains ((see figure 4.13)).



The cycle time of the respective light curtain can be taken over via the configuration software from Leuze electronic (see chapter 14 „Connection to a PC“) or via the respective fieldbus interface (see chapter 10 „Starting up the device - IO-Link interface“ ff.). In the case of the configuration software from Leuze electronic, the cycle time is located in the IODD file under “parameters” for device description - cycle time or, for the fieldbus interface, in the EDS/GSD file under a corresponding module.

Arrangement for cascading with internal trigger

With internal trigger activation, a CML configured as “master light curtain” generates the trigger pulse. This trigger pulse is continuous; this means that no further activation is required from a primary control. This signal is output on the “Trigger-Out” output. All cascaded light curtains receive this trigger via the trigger input and start the measurement according to the timing configuration.



The selection of activation via an internal or external trigger signal is made via the configuration software from Leuze electronic (see chapter 14 „Connection to a PC“) or via the respective field-bus interface (see chapter 10 „Starting up the device - IO-Link interface“ ff.).

For an example configuration, see chapter 13.5 „Example configuration - configuration of a cascade arrangement“.

The following figure shows a wiring example for the cascading of three light curtains via internal trigger:

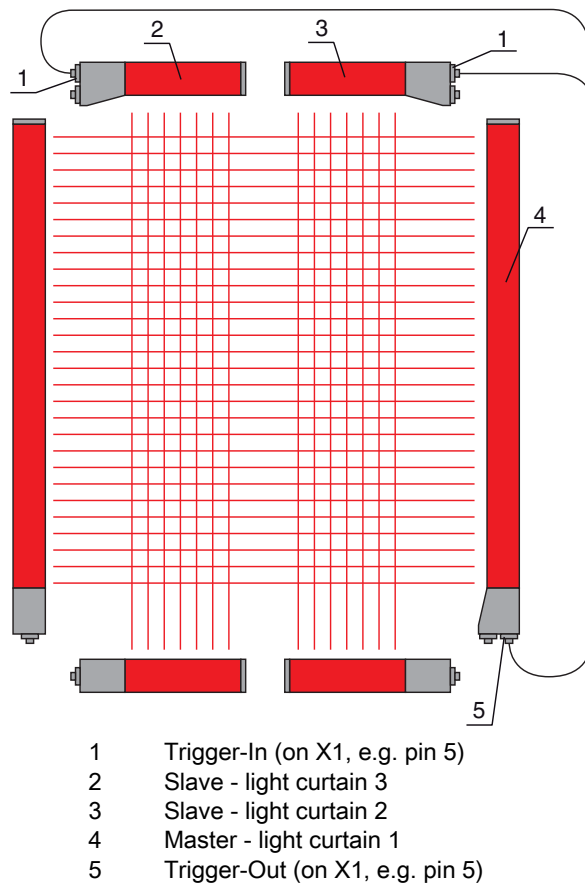
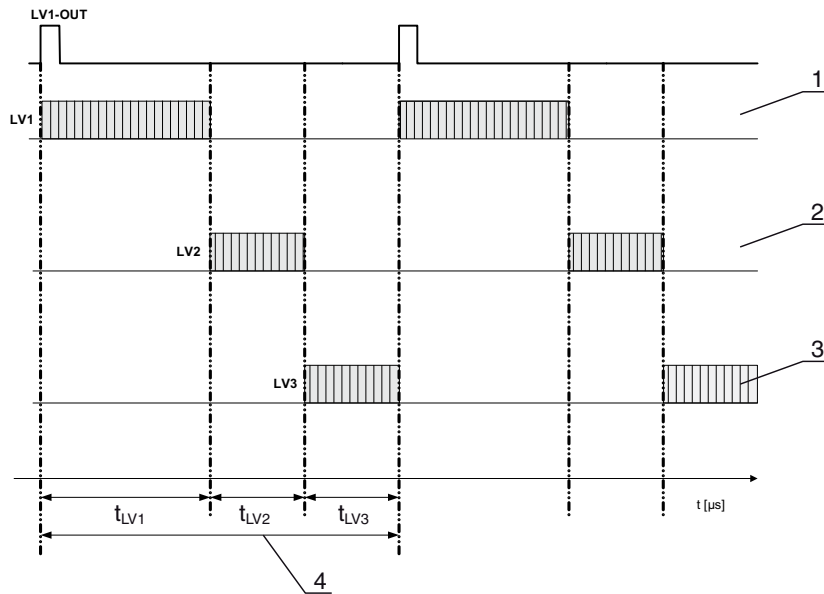

Figure 4.13: Wiring example of three light curtains via internal trigger

The following example shows a configuration of three light curtains via internal trigger.



- 1 Master light curtain LC1 (e.g., X1, pin 5 used as trigger output)
- 2 Slave light curtain LC2 (e.g., X1, pin 5 used as trigger input)
- 3 Slave light curtain LC3 (e.g., X1, pin 5 used as trigger input)
- 4 Total cycle time

Figure 4.14: Example: cascading via internal trigger

4.9 Block evaluation of beam areas

With this function, the quantity of data to be transmitted can be reduced by restricting the imaging accuracy. The minimum resolution of the light curtain is still retained.

To read out the beam states block-wise with a 16-bit or 32-bit word, the individual beams can be mapped to up to 32 areas independent of the maximum beam number. The individual beam information of grouped beams is linked to a logical bit, i.e., each area is represented as 1 bit.

The number of beams in an area can be freely defined. However, the beams must be adjacent to one another. The start beam and the end beam are to be defined as well as the conditions for switching of the area.

Depending on the version of the CML process interface, two or four pins can be configured as output at the X1 connection:

- IO-Link device: four pins
- Analog device and fieldbus device: two pins

NOTICE

Must be observed!

☞ The hold function (see chapter 4.5 „Hold function“) also applies for this block evaluation of beam groups.

4.9.1 Mapping of beam areas to switching outputs

If grouping individual beams or if creating a block, the beam state of any number of adjacent beams (area) can be signaled at a switching output.

It is thereby possible

- to use a specific, single beam for an evaluation (e.g., as trigger signal for a primary control),
- to group the complete measurement field into one switching area and thereby signal at the switching output whether an object (at any position) is located in the measurement field,
- to configure up to 32 switching areas for a reference check or height verification; in many cases, this can make beam-data processing in the primary programmable logic control (PLC) unnecessary.

The switching conditions for the areas can be either AND or OR linked:

| Logic function | Group bit [logic 1/0] | |
|----------------|-----------------------|---|
| AND | 1 | if all beams mapped to the area are interrupted |
| OR | 1 | if more than one beam is interrupted in the selected area |

Areas may be sequential or overlapping. A maximum of 32 areas are available.



The switching behavior or the conditions for switching a switching output on and off can be defined via the configuration software from Leuze electronic (see chapter 14 „Connection to a PC“) or via the respective fieldbus interface (see chapter 10 „Starting up the device - IO-Link interface“).

For an example configuration, see chapter 13.4.3 „Configuration of blanking areas via CANopen interface“.

Example for the configuration of an OR or AND link for a light curtain with 32 beams

| | OR | AND |
|----------------------|---------------------|----------------------|
| Start Beam | 1 | 1 |
| End Beam | 32 | 32 |
| Switch-on condition | 1 beam interrupted | 32 beams interrupted |
| Switch-off condition | 0 beams interrupted | 31 beams interrupted |

Example for a beam configuration into beam areas with 160 beams

The following figure shows how the beam switching areas can be arranged directly next to one another or freely overlapping.

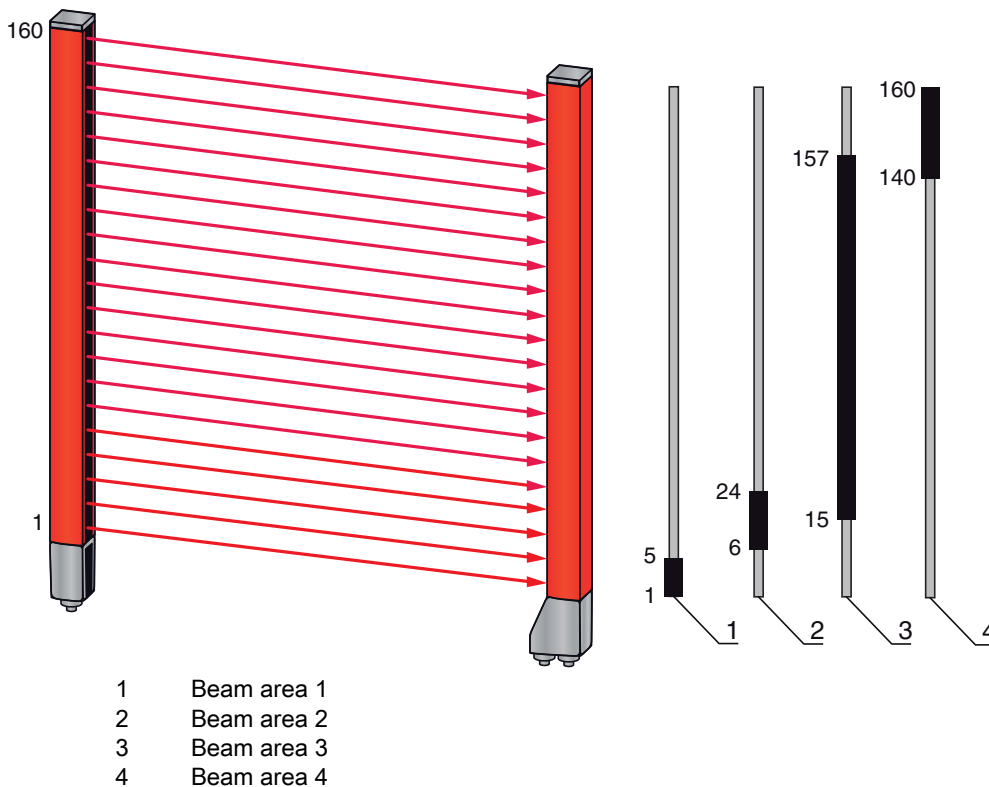

Figure 4.15: Beam areas

For a mapping of previously defined beam areas to, e.g., four switching outputs (Q1 to Q4) see chapter 13.2 „Example configuration: mapping of beams 1 to 32 to output pin 2“.

NOTICE

Increased number of beams for the diagonal- or crossed-beam function!

↳ If the diagonal- or crossed-beam option is activated in beam mode (see chapter 4.1.2 „Diagonal-beam scanning“ or see chapter 4.1.3 „Crossed-beam scanning“), the (increased) number of beams is to be taken into account.

4.9.2 Autosplitting

To read out the beam states block-wise with a 16-bit or 32-bit word, the individual beams can be mapped to up to 32 areas independent of the maximum beam number. The individual beam information of grouped beams is linked to a logical bit, i.e., each area is represented as 1 bit.

Procedure:

- Select the logic combination of the beams within the areas (logical AND / logical OR) Define the number of desired areas (e.g, 16 or 32)

The beams of the CML are automatically divided into the selected number of areas. The states of the areas generated in this way can be read out in the process data by means of the “Area Out - HiWord” and “Area Out - LoWord” parameters.



The autosplitting configuration can be defined via the configuration software from Leuze electronic (see chapter 14 „Connection to a PC“) or via the respective fieldbus interface (see chapter 10 „Starting up the device - IO-Link interface“ ff.).

4.10 Switching outputs

4.10.1 Light / dark switching

The output behavior of switching outputs Q1 to Q4 (or Q1 to Q2) can be configured with respect to light/dark switching. The setting ex works is “light switching”, i.e., the outputs are activated if the light paths are free and become inactive if an object is detected in the measurement field.



The output behavior can be changed to “dark switching” via the receiver control panel and via the configuration software from Leuze electronic (see chapter 14 „Connection to a PC“) or via the respective fieldbus interface (see chapter 10 „Starting up the device - IO-Link interface“ ff.).

4.10.2 Time functions

Each of the individual switching outputs can be assigned one of the time functions described in the following table.

| Time function | Selectable duration | Description |
|-------------------|---------------------|---|
| Start-up delay | 0 ... 65 s | Time that the sensor delays the start-up process after detecting an object. By means of a start-up delay, it is possible to suppress, e.g., upward-protruding packaging remnants (stretch wrap, etc.) during pallet height verification. |
| Switch-off delay | 0 ... 65 s | Time that the sensor delays the switching back of the output if the object leaves the detection range. |
| Pulse stretching | 0 ... 65 s | Minimum time that the state of the output is retained independent of what the sensor detects during this time. Pulse stretching is necessary for, e.g., hole recognition if the PLC cycle time does not register short pulses. |
| Pulse suppression | 0 ... 65 s | Minimum time that a measurement signal must be present in order for the output to switch. Short interference pulses are thereby suppressed. |



The various time functions can be configured via the configuration software from Leuze electronic (see chapter 14 „Connection to a PC“) or via the respective fieldbus interface (see chapter 10 „Starting up the device - IO-Link interface“ ff.).

4.11 Interference suppression (filter depth)

To suppress any faulty measurement values caused by interference (ambient light, increased electromagnetic compatibility (EMC), ...), a threshold for data output can be defined. This threshold corresponds to the “filter depth”.

“Filter depth” means that an interrupted/free beam is not included in the further data evaluation until the same beam status is recorded for the set number of measurement cycles.

Filter depth “1” = the beam states of each measurement cycle are output.

Filter depth “3” = only those beam states that were stable over three measurement cycles are output.



The filter depth can be configured via the configuration software from Leuze electronic (see chapter 14 „Connection to a PC“) or via the respective fieldbus interface (see chapter 10 „Starting up the device - IO-Link interface“ ff.).

5 Applications

The following typical applications with corresponding evaluation function (see chapter 4 „Functions“) exist for the measuring light curtain.

5.1 Height measurement



Figure 5.1: Height measurement

↪ Use the following evaluation function: last interrupted beam (LIB).

5.2 Object measurement

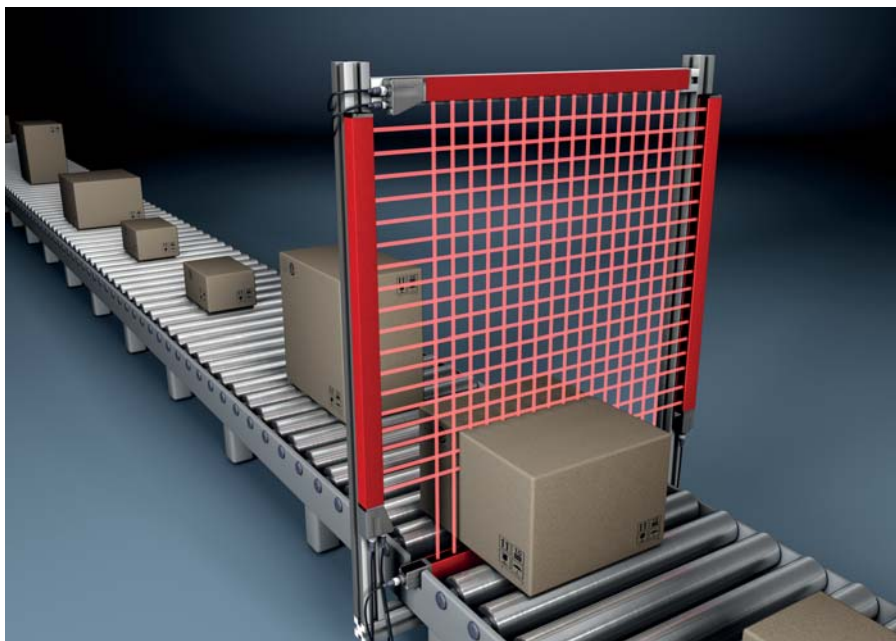

Figure 5.2: Object measurement

↪ Use the following height evaluation function: last interrupted beam (LIB).

↪ Use the following width evaluation function: number of all interrupted beams (TIB).

5.3 Width measurement, position detection



Figure 5.3: Width measurement

- ↪ Use the following evaluation function for width measurement: number of all interrupted beams (TIB).
- ↪ Use the following evaluation function for position detection: single-beam evaluation (beam stream).

5.4 Contour measurement

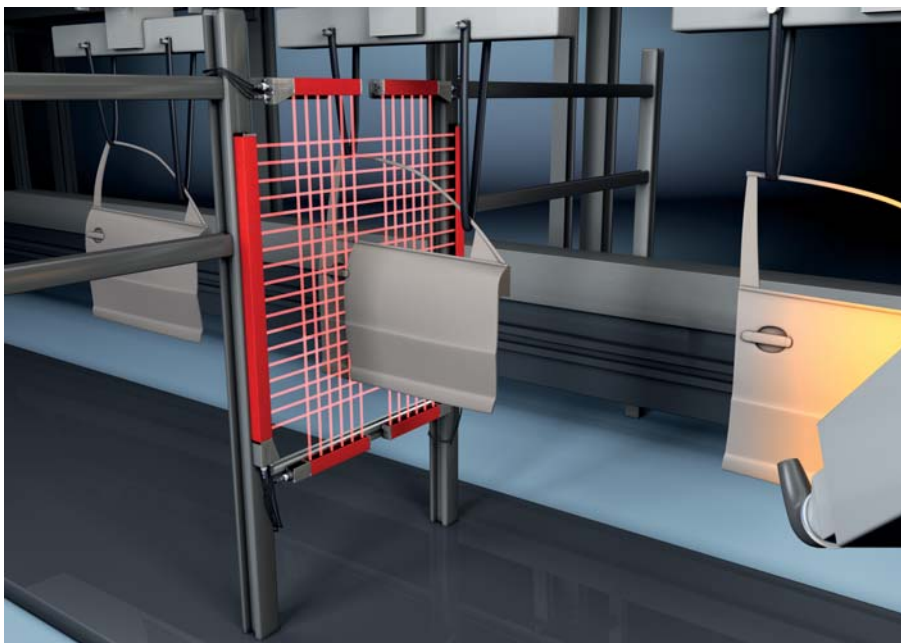

Figure 5.4: Contour measurement

- ↪ Use the following evaluation function: single-beam evaluation (beam stream).

5.5 Gap control/gap measurement



Figure 5.5: Gap control/gap measurement

↪ Use the following evaluation function: single-beam evaluation (beam stream).

5.6 Hole recognition

For a detailed configuration example see chapter 13.3 „Example configuration - hole recognition“.

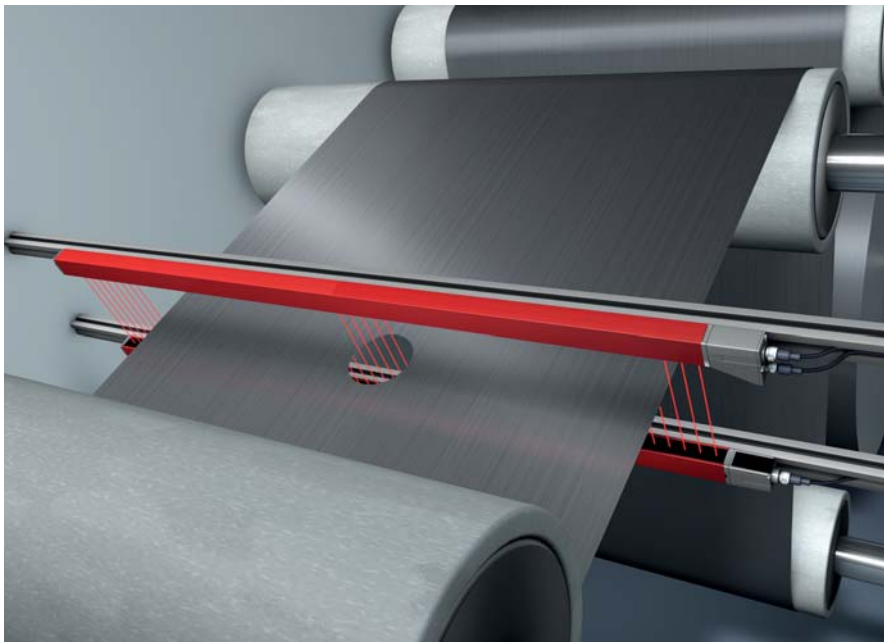

Figure 5.6: Hole recognition

- ↪ For hole recognition within a web material, an area must be defined over the start beam and end beam and mapped to an output. All beams in this area are interrupted. If a beam is “free”, the output switches (inverted OR).
- ↪ If you would like to dynamically track the area (e.g., if the web edge wanders slightly), the area can be “tracked” by means of Start Beam = first interrupted beam (i.e., FIB) and End Beam = last interrupted beam (i.e., LIB).

6 Mounting and installation

6.1 Mounting the light curtain

NOTICE**No reflective surfaces, no mutual interference!**

- ↳ Avoid reflective surfaces near the light curtains.
Objects may otherwise not be precisely detected due to halation.
- ↳ Ensure sufficient distance, suitable positioning or partitioning.
Optical sensors (e.g., other light curtains, photoelectric sensors, etc.) must not interfere with one another.
- ↳ Avoid interference from outside light (e.g., from flash lamps, direct sunlight) on the receiver.
It is possible to achieve this by ensuring sufficient spacing, suitable positioning or partitioning.

Mount the transmitter and receiver as follows:

- ↳ Select the fastening type for transmitter and receiver.
 - Fastening via the T-groove on one side of the standard profile (see chapter 6.3 „Fastening via sliding blocks“).
 - Fastening via the rotating bracket on the ends of the profile (see chapter 6.4 „Fastening via swivel mount“).
 - Fastening via the swiveling mounting brackets or parallel brackets (see chapter 6.5 „Fastening via swiveling mounting brackets“).
- ↳ Have a suitable tool at hand and mount the sensors in accordance with the notices regarding the mounting locations.
- ↳ Mount the transmitter and receiver at the same height or with the same housing reference edge, free of tension and with the base in full contact with the mounting surface.

NOTICE**Must be observed!**

- ↳ For horizontally mounted sensors with lengths of more than 2 m, use an additional mounting bracket in the middle of the sensors.
- ↳ The optical surfaces of transmitter and receiver must be parallel to and opposite one another.
- ↳ The transmitter and receiver connections must point in the same direction.

- ↳ Secure transmitter and receiver against turning or sliding.

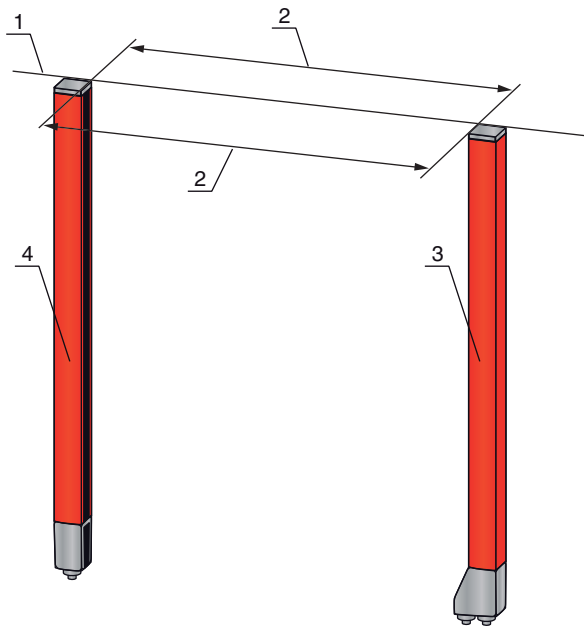

- 1 Same height position / upper edge
- 2 Parallel alignment
- 3 Receiver
- 4 Transmitter

Figure 6.1: Arrangement of transmitter and receiver

i To achieve the maximum operating range limit, transmitter and receiver must be aligned with one another as accurately as possible.

After mounting, you can electrically connect (see chapter 7 „Electrical connection“) and start up (see chapter 8 „Starting up the device - Basic configuration“) the measuring light curtain.

6.2 Definition of directions of movement

The following terms for alignment movements of the sensor around one of its axes are used:

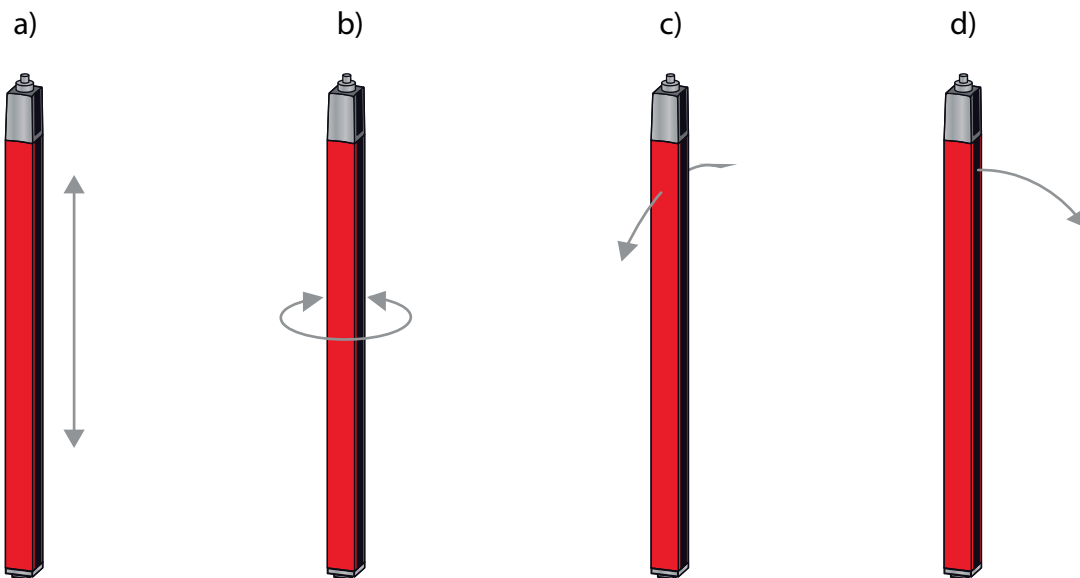

- a Sliding: movement along the longitudinal axis
- b Turning: movement around the longitudinal axis
- c Tilting: lateral turning movement diagonal to the lens cover
- d Pitching: lateral turning movement in the direction of the lens cover

Figure 6.2: Directions of movement during alignment of the sensor

6.3 Fastening via sliding blocks

By default, transmitter and receiver are delivered with two sliding blocks each in the side groove (see chapter 19 „Ordering information and accessories“).

↪ Fasten transmitter and receiver to the machine or system via the lateral T-groove with M6 screws.



Sliding in the direction of the groove is possible, but turning, tilting and pitching is not.

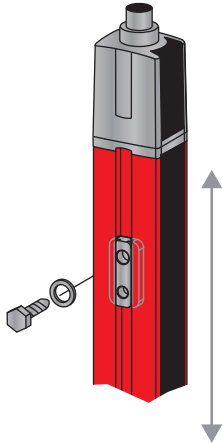

Figure 6.3: Mounting via sliding blocks

6.4 Fastening via swivel mount

When mounting with the BT-2R1 swivel mount ((see table 19.10)), sold separately, the sensor can be aligned as follows:

- Sliding through the vertical threaded holes in the wall plate of the swivel mount
- Turning by 360° around the longitudinal axis by fixing on the screw-on cone
- Tilting around main axis
- Pitching through horizontal threaded holes in the wall mounting

The wall mounting through threaded holes makes it possible to lift the mounting bracket over the connection cap after the screws have been loosened. Therefore, the mounting brackets do not need to be removed from the wall when exchanging the device. Loosening the screws is sufficient.

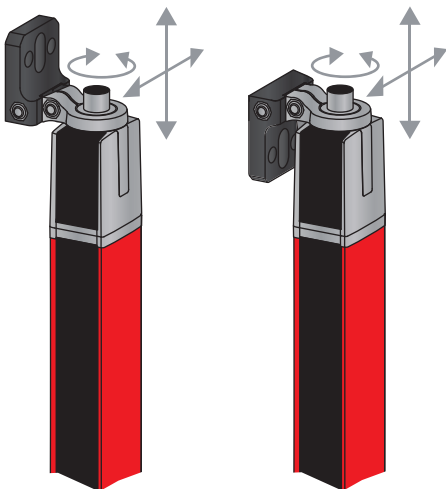

Figure 6.4: Mounting via swivel mount

6.4.1 One-sided mounting on the machine table

The sensor can be mounted directly on the machine table via an M5 screw on the blind hole in the end cap. On the other end, a BT-2R1 swivel mount can be used, for example, so that turning movements for alignment are possible despite the fact that the sensor is mounted on one side.

NOTICE

Avoid reflection bypasses at the machine table!

☞ Make sure that reflections on the machine table are prevented reliably.

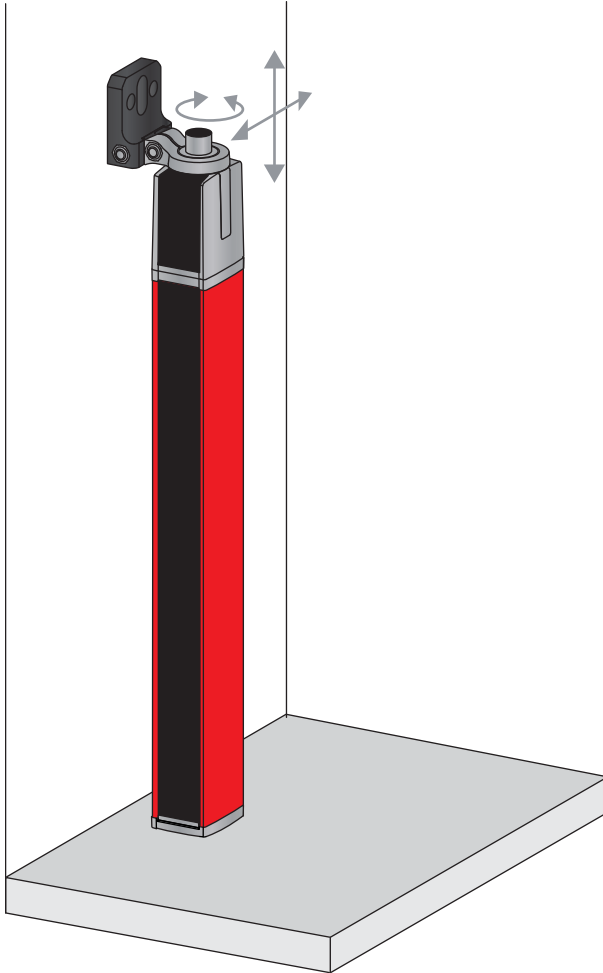

Figure 6.5: Mounting directly on the machine table

6.5 Fastening via swiveling mounting brackets

When mounting with the BT-2SSD/BT-4SSD or BT-2SSD-270 swiveling mounting brackets ((see table 19.10)), sold separately, the sensor can be aligned as follows:

- Sliding in the direction of slot
- Turning $\pm 8^\circ$ around the longitudinal axis

The BT-SSD swiveling mounting brackets are also equipped with a vibration damper.

7 Electrical connection

7.1 Connection cables



Use only the cables listed in the accessories (see chapter 19 „Ordering information and accessories“) for all connections (connection cable, analog/IO-Link/fieldbus connection cable, cable between transmitter and receiver).

Use only shielded cables for the cable between transmitter and receiver.

| |
|---|
| NOTICE |
| Competent persons and approved purpose! |
| <ul style="list-style-type: none"> ↳ Only allow competent persons to perform the electrical connection. ↳ Select the functions so that the measuring light curtain can be used as intended (see chapter 2.1 „Approved purpose and foreseeable improper operation“). |

7.2 Device connections

The measuring light curtain is provided with the following connections:

| Device connection | Type | Function |
|-------------------|----------------------|---|
| X1 on Receiver | M12 connector, 8-pin | Control interface and data interface: <ul style="list-style-type: none"> • Voltage supply • Switching outputs and control inputs • Configuration interface • Synchronization interface (for devices with fieldbus interfaces) |
| X2 on Receiver | M12 socket, 5-pin | Synchronization interface and fieldbus interface: <ul style="list-style-type: none"> • Synchronization interface (for devices with analog output or IO-Link interface) • Fieldbus interface (for CANopen/Profibus devices) |
| X3 on Transmitter | M12 connector, 5-pin | Synchronization interface: <ul style="list-style-type: none"> • Synchronization interface (for all controller types) |

7.3 Electrical connection of the system components for IO-Link devices and analog devices

The electrical connection of IO-Link devices and analog devices is established in the same way.

| |
|--|
| NOTICE |
| Ground the light curtain! |
| <ul style="list-style-type: none"> ↳ Ground the light curtain before establishing an electrical connection or connecting the voltage supply. ↳ Connect the transmitter and receiver housing to the protective conductor on the machine star point via the PE screw on the grounding slot nut. ↳ Tighten the small Allen screw to ensure a secure connection between the grounding slot nut and housing. |

- ↳ Connect connection X1 to the power supply and the control using the appropriate connection cable.
- ↳ Connect connection X2 to connection X3 using the appropriate connection cable.

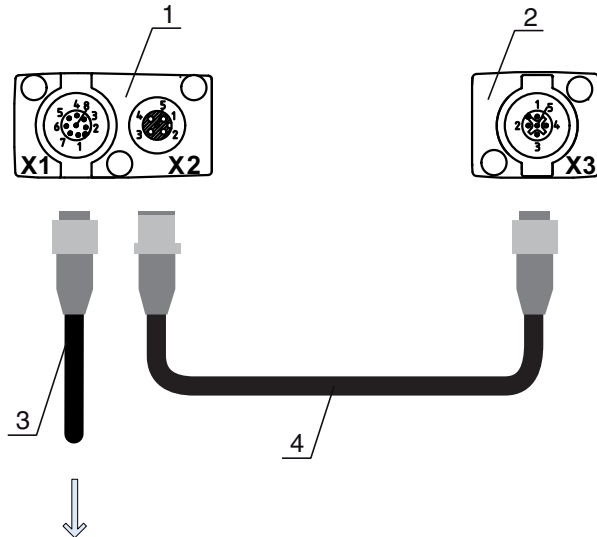

PWR IN/OUT

- 1 Receiver (R)
- 2 Transmitter (T)
- 3 Connection cable (M12 socket, 8-pin)
- 4 Synchronization cable (M12 plug/socket, 5-pin)

Figure 7.1: Electrical connection for IO-Link devices/analog devices

7.3.1 X1 pin assignment for IO-Link devices (logic and power on the receiver)

8-pin, M12 plug (A-coded) for connecting to PWR IN/OUT and IO-Link interface.

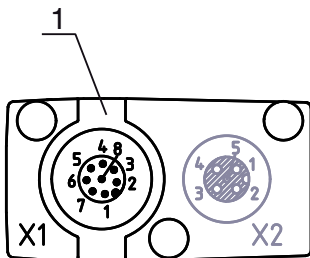

- 1 M12 plug (8-pin, A-coded)

Figure 7.2: X1 connection for IO-Link devices

Table 7.1: X1 pin assignment for IO-Link devices

| Pin | X1 - logic and power on the receiver | Core color |
|-----|---|------------|
| 1 | VIN: +24 V DC supply voltage | white |
| 2 | IO 1: input/output (configurable) Ex works: teach input (Teach In) | brown |
| 3 | GND: ground (0 V) | green |
| 4 | C/Q: IO-Link communication | yellow |
| 5 | IO 2: input/output (configurable) Ex works: trigger input (Trigger-In) | gray |
| 6 | IO 3: input/output (configurable) | pink |
| 7 | IO 4: input/output (configurable) | blue |
| 8 | GND: ground (0 V) | red |

Connection cables: (see table 19.3).

 The specified core colors apply only if the cables from Leuze electronic are used ((see table 19.3)).

Ex works, input/output IO 1 (pin 2) is assigned the teach-in function and input/output IO 2 (pin 5) is assigned the trigger-in function.

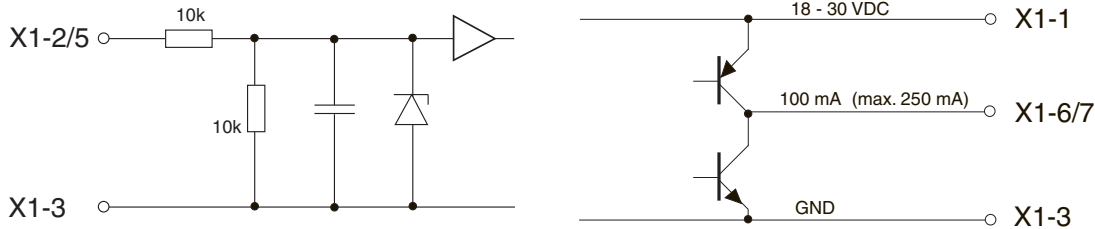
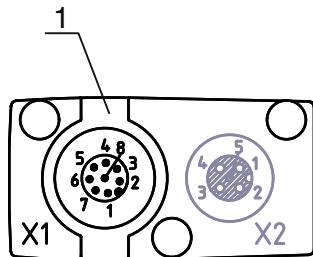

Figure 7.3: Input/output schematic diagram

| |
|---|
| NOTICE |
| Single assignment of input functions! |
| ↪ Each input function may only be used one time. If multiple inputs are assigned the same function, malfunctions may occur. |

7.3.2 X1 pin assignment for analog devices (logic and power on the receiver)

8-pin, M12 plug (A-coded) is used for connecting to PWR IN/OUT and analog interface.



1 M12 plug (8-pin, A-coded)

Figure 7.4: X1 connection for analog devices

Table 7.2: X1 pin assignment for analog devices

| Pin | X1 - logic and power on the receiver | Core color |
|-----|--|------------|
| 1 | VIN: +24 V DC supply voltage | white |
| 2 | IO 1: input/output (configurable) Ex works: teach input | brown |
| 3 | GND: ground (0 V) | green |
| 4 | C/Q: IO-Link communication | yellow |
| 5 | IO 2: input/output (configurable) Ex works: trigger input | gray |
| 6 | 0-10 V: analog voltage output | pink |
| 7 | 4-20 mA: analog current output | blue |
| 8 | AGND: analog output reference potential | red |

Connection cables: (see table 19.3).

 The specified core colors apply only if the cables from Leuze electronic are used ((see table 19.3)).

NOTICE
Select either voltage output (pin 6) or current output (pin 7)!
 ↳ Voltage output and current output (pin 6 and pin 7) are not available simultaneously. The type of analog signal must be selected either via the IO-Link configuration software or via the receiver control panel (see chapter 9 „Starting up the device - Analog output“).

NOTICE
Signal crosstalk in analog operation during simultaneous IO-Link communication!
 If the simultaneous operation of IO-Link and analog signals is desired, perform one of the following two measures:
 ↳ Wire a filter to the PLC analog output.
 ↳ Use shielded cables for the analog lines.

NOTICE
Single assignment of input functions!
 ↳ Each input function may only be used one time. If multiple inputs are assigned the same function, malfunctions may occur.

NOTICE
Permissible load resistance on the analog output!
 When connecting the analog output, note the permissible load resistance.
 ↳ Voltage output 0 ... 10 V DC / 0 ... 11 V DC: $R_L \geq 2 \text{ k}\Omega$
 ↳ Current output 4 ... 20 mA DC / 0 ... 24 mA DC: $R_L \leq 500 \Omega$

7.3.3 X2/X3 pin assignment for IO-Link devices/analog devices (receiver or transmitter)

5-pin, M12 socket/plug (A-coded) for the connection between transmitter and receiver.

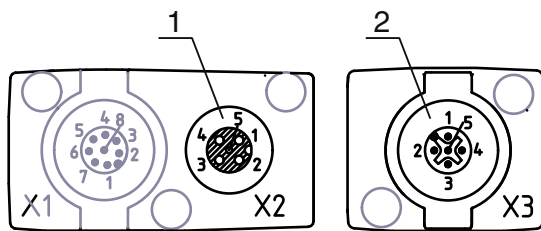

- 1 M12 socket X2 (5-pin, A-coded)
- 2 M12 plug X3 (5-pin, A-coded)

Figure 7.5: X2/X3 connection for IO-Link devices/analog devices

Table 7.3: X2/X3 pin assignment for IO-Link devices/analog devices

| Pin | X2/X3 - Transmitter and receiver | Core color |
|-----|----------------------------------|------------|
| 1 | SHD: FE functional earth, shield | shield |
| 2 | VIN: +24 V DC supply voltage | red |
| 3 | GND: ground (0 V) | black |
| 4 | RS 485 Tx+: synchronization | white |
| 5 | RS 485 Tx-: synchronization | blue |

Connection cables: (see table 19.4).

 The specified core colors apply only if the cables from Leuze electronic are used ((see table 19.4)).

7.4 Electrical connection of the system components for fieldbus devices

The electrical connection is established in the same way for all fieldbus devices.

- ⚡ Ground the light curtain before establishing an electrical connection or connecting the voltage supply.
Connect the transmitter and receiver housing to the protective conductor on the machine star point via the PE screw on the grounding slot nut.
Tighten the small Allen screw to ensure a secure connection between the grounding slot nut and housing.
- ⚡ Connect connection X1 with the Y-connection cable; connect the short end to the power supply or configuration software interface and connect the long end to connection X3 on the transmitter.
- ⚡ Connect connection X2 on the receiver with the Y-connection cable; use both ends to connect to BUS IN or BUS OUT on the other network devices.

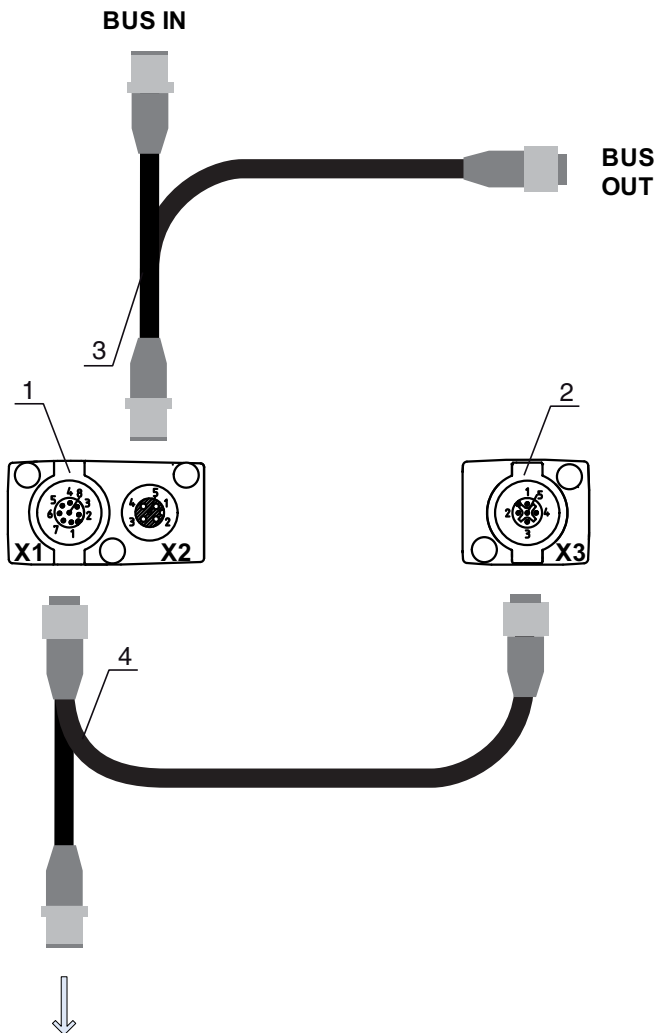

PWR IN/OUT

- 1 Receiver (R)
- 2 Transmitter (T)
- 3 Y-fieldbus cable (M12 plug/socket, 5-pin)
- 4 Y-fieldbus cable and synchronization cable (M12 socket/plug, 8-pin/5-pin)

Figure 7.6: Electrical connection for fieldbus devices

7.4.1 Pin assignment for fieldbus devices

X1 pin assignment (logic and power on the receiver and connection to transmitter)

8-pin, M12 plug (A-coded) for connecting to PWR IN/OUT and transmitter.

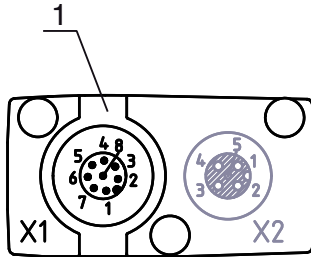

1 M12 plug (5-pin, A-coded)

Figure 7.7: X1 connection for fieldbus devices

Table 7.4: X1 pin assignment for fieldbus devices

| Pin | X1 - logic and power on the receiver and connection to transmitter | Core color |
|-----|--|------------|
| 1 | VIN: +24 V DC supply voltage | white |
| 2 | IO 1: input/output (configurable) | brown |
| 3 | GND: ground (0 V) | green |
| 4 | C/Q: IO-Link communication | yellow |
| 5 | IO 2: input/output (configurable) | gray |
| 6 | Synchronization | pink |
| 7 | Synchronization | blue |
| 8 | SHD: FE functional earth, shield | shield |

Connection cables: (see table 19.5).



The specified core colors apply only if the cables from Leuze electronic are used ((see table 19.5)).

Pin assignment on the short end of the Y-connection cable (logic and power)

5-pin, M12 plug (A-coded) on the short end of the Y-connection cable for connecting to PWR IN/OUT.

PWR IN/OUT



1 M12 plug (5-pin, A-coded)

Figure 7.8: X1 connection on the short end of the Y-connection cable - for fieldbus devices

Table 7.5: X1 pin assignment on the short end of the Y-connection cable - for fieldbus devices

| Pin | X1 - short end of the Y-connection cable | Core color |
|-----|--|------------|
| 1 | VIN: +24 V DC supply voltage | brown |
| 2 | IO 1: input/output (configurable) Ex works: teach input | white |
| 3 | GND: ground (0 V) | blue |
| 4 | C/Q: IO-Link communication | black |
| 5 | IO 2: input/output (configurable) Ex works: trigger input | green |

Connection cables: (see table 19.6).

| |
|---|
| NOTICE |
| Single assignment of input functions! |
| ↪ Each input function may only be used one time. If multiple inputs are assigned the same function, malfunctions may occur. |

Pin assignment on the long end of the Y-connection cable (logic and power)

The pin assignment on the long end of the Y-connection cable for synchronization of transmitter and receiver for devices with fieldbus interface is the same as for IO-Link/analog (see chapter 7.3.1 „X1 pin assignment for IO-Link devices (logic and power on the receiver)“).

X2 pin assignment (CANopen interface)

5-pin, M12 plug (A-coded) for a CANopen device for connecting to BUS IN/BUS OUT.

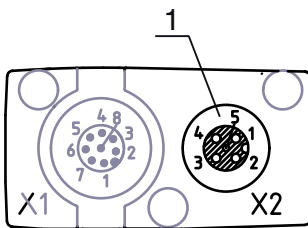

1 M12 socket (5-pin, A-coded)

Figure 7.9: X2 connection for CANopen devices

Table 7.6: X2 pin assignment for CANopen devices

| Pin | X2 - CANopen fieldbus | Core color |
|-----|----------------------------------|------------|
| 1 | SHD: FE functional earth, shield | shield |
| 2 | NC: (optional CAN_+5 V) | red |
| 3 | CAN_GND: ground (0 V) | black |
| 4 | CAN_H: | white |
| 5 | CAN_L: | blue |

Connection cables: (see table 19.7).

i The specified core colors apply only if the cables from Leuze electronic are used ((see table 19.7)).

X2 pin assignment (Profibus interface)

5-pin, M12 plug (B-coded) for a Profibus device for connecting to BUS IN/BUS OUT.

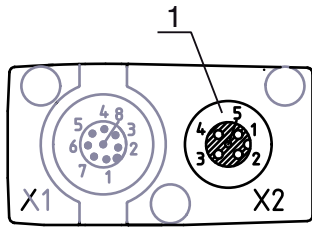

1 M12 socket (5-pin, B-coded)

Figure 7.10: X2 connection for Profibus devices

Table 7.7: X2 pin assignment for Profibus devices

| Pin | X2 - Profibus fieldbus | Core color |
|-----|--|------------|
| 1 | VP: +5 V supply voltage | white |
| 2 | PB_A: receive/transmit data, A-cable (Tx-) | red |
| 3 | PB_GND: ground (0 V) | black |
| 4 | PB_B (P): receive/transmit data, B-cable (Tx+) | green |
| 5 | SHD: FE functional earth, shield | shield |

Connection cables: (see table 19.8).

Profibus termination: (see table 19.9).

i The specified core colors apply only if the cables from Leuze electronic are used ((see table 19.8)).

X3 pin assignment (transmitter)

The pin assignment on the transmitter for devices with fieldbus interface is the same as for IO-Link/analog (see chapter 7.3.3 „X2/X3 pin assignment for IO-Link devices/analog devices (receiver or transmitter)“).

Connection cables: (see table 19.5).

7.5 Electrical supply

With regard to the data for the electrical supply, (see table 18.7).

8 Starting up the device - Basic configuration

The basic configuration includes the alignment of transmitter and receiver and the basic configuration steps via the receiver control panel.

The following optional basic functions are available for operation and configuration via the receiver control panel:

- Define digital inputs/outputs
- Defining the filter depth
- Defining the display properties
- Changing the language
- Product information
- Resetting to factory settings

8.1 Aligning transmitter and receiver

NOTICE

Alignment during start-up!

- ↪ The alignment performed during start-up should only be performed by qualified personnel.
- ↪ Observe the data sheets and mounting instructions of the individual components.

Prerequisites:

- The measuring light curtain has been mounted (see chapter 6 „Mounting and installation“) and connected (see chapter 7 „Electrical connection“) correctly.

↪ Switch on the measuring light curtain.

NOTICE

Alignment operation!

- ↪ When switched on for the first time ex works, the sensor automatically starts in alignment operation.
- ↪ You can switch from measurement operation to alignment operation via the menu.

↪ Check whether the green LEDs on the receiver control panel and transmitter illuminate continuously.

The display shows the alignment state of the first beam (FB) and last beam (LB) beam via two bar graph fields.



Figure 8.1: Example: display showing an incorrectly aligned light curtain

Align the light curtain.

↪ Loosen the fastening screws of the transmitter and receiver.



Loosen the screws only enough so that the devices can just be moved.

↪ Turn or slide the transmitter and receiver until the optimum position is reached and the bar graph indicators show the maximum value for the alignment.

↪ Align the transmitter and receiver with one another until the maximum value of the respective bar graph indicator is reached for the alignment of the first beam (FB) and the last beam (LB).

NOTICE
Minimum sensitivity of the sensor!
 ↪ In order to perform a teach, a minimum level must be reached in the bar graph indicator.



Figure 8.2: Display showing an optimally aligned light curtain

↪ Tighten the fastening screws of the transmitter and receiver.
 Transmitter and receiver are aligned.

Switching to measurement operation

After aligning, switch to measurement operation.

↪ Select **Main Settings > Mode > Operation**.

The display in the receiver of the measuring light curtain shows the measurement operation states with the number of all interrupted beams (TIB) and the logic states of all four inputs/outputs (IOs).



Figure 8.3: Display showing the measurement operation state of the light curtain

The structure of the configuration in the receiver control panel menu is as follows:

| Level 0 | Level 1 | Level 2 | Description |
|---------------|---------|---------|--|
| Main Settings | Mode | | Measurement operation Alignment |
| | Command | | Teach Reset Factory Settings |

Switching to alignment operation

You can switch from measurement operation to alignment operation via the menu.

↪ Select **Main Settings > Mode > Alignment**.

The structure of the configuration in the receiver control panel menu is as follows:

| Level 0 | Level 1 | Level 2 | Description |
|---------------|---------|---------|--|
| Main Settings | Mode | | Measurement operation Alignment |
| | Command | | Teach Reset Factory Settings |

The next configuration step is teaching the environmental conditions (teach).

8.2 Teaching the environmental conditions

During teaching, the system checks whether the signals of all beams are within a certain corridor. This means that a teach event generally regulates all beams to the preset performance reserve for the current operating range. This ensures that all beams exhibit an identical switching behavior.

The performance reserve can be set to four levels:

- High performance reserve
- Medium performance reserve
- Low performance reserve
- Transparent objects

Teaching can be triggered:

- via the control panel
- via the teach input (if configured)
- via the fieldbus interface (IO-Link, CANopen, Profibus)
- via the configuration interface (IO-Link connected to the PC)

In addition, teaching is also possible with free light paths (without blanking) and with obstacles in the light path (auto blanking).



Depending on the PLC configuration interface (for IO-Link or fieldbus), it is possible, for example, to make the following parameter settings via the configuration software from Leuze electronic (see chapter 14 „Connection to a PC“) or via the respective fieldbus interface (see chapter 10 „Starting up the device - IO-Link interface“ ff.):

The sensitivity levels (e.g., high performance reserve for stable operation, medium performance reserve and low performance reserve) are configured ex works with “high performance reserve for stable operation”. The “low performance reserve” configuration enables the detection of partially transparent objects.

Selection of whether the teach values are to be stored permanently or only temporarily (while the operating voltage is applied). The configuration ex works is for permanent (non-volatile) storage.

A teach event can be performed both directly from measurement operation as well as from alignment operation.

NOTICE

Perform teach after configuring performance reserve!

↪ A teach is to be performed after changing the performance reserve.

↪ A teach is also always to be performed after changing the beam scanning mode (parallel-/diagonal-/crossed-beam).

Prerequisites:

- The measuring light curtain must be correctly aligned (see chapter 8.1 „Aligning transmitter and receiver“).
- The bar graph indicator must show a minimum level.

↪ You can use one of the following teach types:

- Teach via receiver control panel (see chapter 8.2.1 „Teach via receiver control panel“).
- Teach via teach input (see chapter 8.2.2 „Teaching via a control signal from the control“).
- Teach via fieldbus interface (IO-Link, CANopen, Profibus) (see chapter 10 „Starting up the device - IO-Link interface“, see chapter 11 „Starting up the device - CANopen fieldbus interface“, see chapter 12 „Starting up the device - Profibus fieldbus interface“).
- Teach via the configuration interface (IO-Link connected to PC) (see chapter 14 „Connection to a PC“).

8.2.1 - Teach via receiver control panel

If blanking areas are configured via the configuration software interface, a teach event is performed that takes these blanking areas into account (blanking teach or auto blanking, see chapter 4.6 „Blanking“).

NOTICE

Conditions for performing a teach!

- ↪ When teaching without preconfigured blanking areas, the light path must always be completely free. A teaching error will otherwise occur.
- ↪ If the light path is partially interrupted by structural elements, the permanently interrupted beams can be suppressed by means of blanking. To automatically suppress the affected beams during teaching, the number of blanking areas is to be configured via the configuration software interface (see chapter 4.6.1 „Auto blanking during teaching“).



During a blanking teach or auto blanking, an “additional distance” is always added to the beams detected as interrupted. Safer operation is thereby achieved, e.g., in the case of vibrating guides, etc., in the “blanked” area.

Optimization of the blanked beams is to be performed via a software interface configuration.

A maximum of four adjacent areas of suppressed beams (blanking areas) can be configured.

A maximum of 50% of the existing beams can be suppressed.

The structure of the configuration in the receiver control panel menu is as follows:

| Level 0 | Level 1 | Level 2 | Description |
|---------------|---------|---------|--|
| Main Settings | Mode | | Measurement operation Alignment |
| | Command | | Teach Reset Factory Settings |

↪ Select **Main Settings > Command > Teach**.

↪ Press the **↵** button to execute the teach.

The display shows

Waiting

If the teach was started while in measurement operation, the display returns to the measurement operation display after a successful teach (see chapter 8.1 „Aligning transmitter and receiver“).

If the teach was started from alignment operation, the display returns to the bar graph display following a successful teach and shows the received signal level of the first beam (FB) and the last beam (LB) as bars in the bar graph (see chapter 8.1 „Aligning transmitter and receiver“).

If teach is successful, both bars display the maximum value.



Figure 8.4: Display after successful teach

If no bars are visible in the bar graph display for the first beam (FB) and the last beam (LB), an error has occurred. It is possible, e.g., that the reception signal is too low. You can correct errors according to the error list (see chapter 15 „Troubleshooting“).

The next configuration step is to check the alignment.

8.2.2 Teaching via a control signal from the control

Teach input (Teach In)

This input can be used to perform a teach following initial commissioning, change of the alignment or during operation. During this procedure, the transmitter and receiver adjust themselves to the maximum performance reserve according to the distance.

To trigger a teach, a pulse must be applied on the X1 connection on the receiver IO1 = pin 2 (factory setting) for longer than 20 ms ... but less than 80 ms.

Depending on the configuration (PNP or NPN), this corresponds to the following signal response:

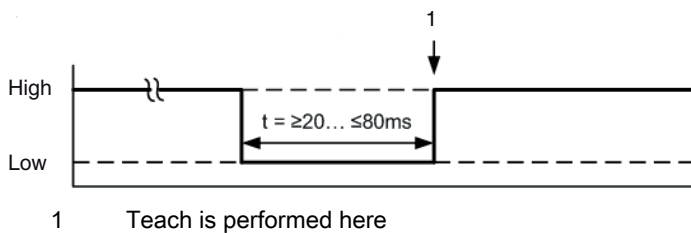

Figure 8.5: Control signals for line teach with PNP configuration

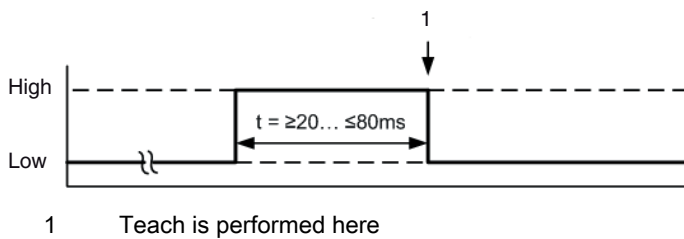

Figure 8.6: Control signals for line teach with NPN configuration

Performing a teach via the line input

| |
|---|
| NOTICE |
| Conditions for performing a teach via the line input (teach-in) |
| 👉 For teaching, the light path must always be completely free; otherwise a teaching error occurs. |

Prerequisites:

- The measuring light curtain must be correctly aligned (see chapter 8.1 „Aligning transmitter and receiver“).
- A connection must be established between PLC and the line input (teach-in).

👉 Send a teach signal to the teach input via the control (see *** 'Teach input (Teach In)' on page 54 *** for the data) to trigger a teach.

The display on the receiver control panel shows

| Waiting

Following a successful teach, the display switches back to the bar graph diagram (alignment mode).

If teach is successful, both bars display the maximum value.



Figure 8.7: Display after successful teach

The next configuration step is to check the alignment.

8.3 Check alignment

Prerequisites:

- The measuring light curtain must first be correctly aligned and a teach must be performed.
- ↪ Check whether the green LEDs on the receiver control panel and transmitter illuminate continuously.
- ↪ Use the bar graph indicator to check whether the light curtain is optimally aligned, i.e., whether the maximum bar graph indicator is reached for both the first beam (FB) and the last beam (LB).
- ↪ Use the bar graph indicator to check the optimum alignment of the measuring light curtain if you have corrected an error that occurred.

The next configuration steps:

- Perform extended configurations on the receiver control panel if necessary (see chapter 8.4 „Extended configurations on the receiver control panel menu“)
- Start up CML light curtains with analog output (see chapter 9 „Starting up the device - Analog output“)
- Start up CML light curtains with IO-Link interface (see chapter 10 „Starting up the device - IO-Link interface“)
- Start up CML light curtains with CANopen interface (see chapter 11 „Starting up the device - CANopen fieldbus interface“)
- Start up CML light curtains with Profibus interface (see chapter 12 „Starting up the device - Profibus fieldbus interface“)

8.4 Extended configurations on the receiver control panel menu



It is not mandatory that extended configurations be performed on the receiver control panel menu for all process interface types in order to start up a measuring light curtain.

8.4.1 Define digital inputs/outputs

The parameters for the switching outputs are configured with the IO logic, IO pin x (for IO-direction, inversion, input function, output function, area logic, start beam, end beam) configurations.



The individual configuration steps are not described separately for the extended configuration combinations.

When configuring start and end beam, you can configure values of up to 1776. Values above 1776 (to 1999) are not accepted and must be entered again.

The structure of these configurations in the receiver control panel menu is as follows (multiple configurations displayed simultaneously):

Examples

Configuration of pin 2 as PNP switching output

The following example shows a configuration of pin 2 as PNP switching output with additional configurations, such as area logic “OR” with a beam area of 1 ... 32 and beam 1 as start beam according to the following table.

| | OR |
|----------------------|---------------------|
| Start Beam | 1 |
| End Beam | 32 |
| Switch-on condition | 1 beam interrupted |
| Switch-off condition | 0 beams interrupted |

| Level 0 | Level 1 | Level 2 | Description | | |
|-------------|---------------|----------|--------------|--------------|---------------------------|
| Digital IOs | IO Logic | IO Pin 2 | Negative NPN | Positive PNP | |
| | | | <hr/> | | |
| | IO-Direction | | Output | Input | |
| | Inversion | | Normal | Inverted | |
| | Input-funct. | | Off | Trigger In | Teach In |
| | Output-Funct. | | Off | Area Out | Warn Out Trigger Out |
| | Area Logic | | AND | OR | |
| | Start Beam | | 001 | | |
| | End Beam | | 032 | | |

Configuration of pin 2 as PNP warning output

The following example shows the configuration of pin 2 as PNP warning output.

| Level 0 | Level 1 | Level 2 | Description | | |
|-------------|---------------|----------|---------------|--------------|---------------------------|
| Digital IOs | IO Logic | IO Pin 2 | Negative NPN | Positive PNP | |
| | | | <hr/> | | |
| | IO-Direction | | Output | Input | |
| | Inversion | | Normal | Inverted | |
| | Input-funct. | | Off | Trigger In | Teach In |
| | Output-funct. | | Off | Area Out | Warn Out Trigger Out |
| | Area Logic | | AND | OR | |
| | Start Beam | | (enter value) | | |
| | End Beam | | (enter value) | | |

Configuration of pin 2 as PNP trigger output

The following example shows the configuration of pin 2 as PNP trigger output.

| Level 0 | Level 1 | Level 2 | Description | | |
|-------------|--------------|----------|--------------|--------------|--|
| Digital IOs | IO Logic | IO Pin 2 | Negative NPN | Positive PNP | |
| | | | <hr/> | | |
| | IO-Direction | | Output | Input | |
| | Inversion | | Normal | Inverted | |

| Level 0 | Level 1 | Level 2 | Description |
|---------|---------|----------------------|--|
| | | Input-funct. | Off Trigger In Teach In |
| | | Output-funct. | Off Area Out Warn Out Trigger Out |
| | | Area Logic | AND OR |
| | | Start Beam | (enter value) |
| | | End Beam | (enter value) |

Configuration of pin 5 as PNP trigger input

The following example shows the configuration of pin 5 as PNP trigger input.

| Level 0 | Level 1 | Level 2 | Description |
|-------------|----------|---------------------|--|
| Digital IOs | IO Logic | | Negative NPN Positive PNP |
| | | | |
| | IO pin 5 | IO-Direction | Output Input |
| | | Inversion | Normal Inverted |
| | | Input-funct. | Off Trigger In Teach In |
| | | Output-funct. | Off Area Out Warn Out Trigger Out |
| | | Area Logic | AND OR |
| | | Start Beam | (enter value) |
| | | End Beam | (enter value) |

A teach input is configured according to the same principle.

8.4.2 Inversion of the switching behavior (light/dark switching)

Light/dark switching is configured with this configuration.



For all digital process interface types, the configuration can also be performed via the configuration software from Leuze electronic (see chapter 14 „Connection to a PC“) or via the respective fieldbus interface (see chapter 10 „Starting up the device - IO-Link interface“ ff.).

The following example shows how the switching output is switched from light switching (normal) to dark switching (inverted).

The structure of the configuration in the receiver control panel menu is as follows:

| Level 0 | Level 1 | Level 2 | Description |
|-------------|----------|---------------------|--|
| Digital IOs | IO Logic | | Negative NPN Positive PNP |
| | | | |
| | IO Pin 2 | IO-Direction | Output Input |
| | | Inversion | Normal Inverted |
| | | Input-funct. | Off Trigger In Teach In |
| | | Output-funct. | Off Area Out Warn Out Trigger Out |
| | | Area Logic | AND OR |
| | | Start Beam | (enter value) |
| | | End Beam | (enter value) |

↩ Select **Digital IOs > IO Pin x > Normal/Inverted.**

↩ Press the **←** button to save the selected value.

8.4.3 Defining the filter depth

The filter depth is configured with this configuration. The filter depth is used to specify that an evaluation of the measurement values occurs only once the beam states are stable over multiple measurement cycles.

Example: with a filter depth of 5, five measurement cycles must be consistent before a beam evaluation is performed. For further information, see also the description of interference suppression (see chapter 4.11 „Interference suppression (filter depth)“).



For all digital process interface types, the configuration can also be performed via the configuration software from Leuze electronic (see chapter 14 „Connection to a PC“) or via the respective fieldbus interface (see chapter 10 „Starting up the device - IO-Link interface“ ff.).

When configuring the filter depth, you can enter values of up to 255. Values above 255 (to 299) are not accepted and must be entered again.

The structure of the configuration in the receiver control panel menu is as follows:

| Level 0 | Level 1 | Level 2 | Description |
|---------------|--------------|---------|---------------------------------------|
| Main Settings | Mode | | Measurement operation Alignment |
| | Command | | Teach Reset Factory Settings |
| | Filter Depth | | (enter value) min = 1 max = 255 |

Select **Main Settings > Filter Depth**.

8.4.4 Defining the display properties

With these configurations for the display, the brightness and a time unit for darkening the display are defined.

Visibility:

- **Off:** no display; the display remains dark until a button is pressed.
- **Dark:** text is only slightly visible.
- **Normal:** text is visible with good contrast.
- **Bright:** text appears very bright.
- **Dynamic:** The display darkens successively over the course of the number of seconds configured under **Time unit**. During this time span, the display passes through all levels, from **bright to off**.



After approx. 5 minutes without button actuation, configuration mode is exited and the display changes to the previous mode.

In the **dark**, **normal** and **bright** modes, the display is completely inverted after approx. 15 minutes to prevent the LEDs from burning in.

When configuring the time unit (s), you can enter values of up to 240 seconds. Values above 240 (to 299) are not accepted and must be entered again.

The structure of these configurations in the receiver control panel menu is as follows:

| Level 0 | Level 1 | Level 2 | Description |
|---------|----------|---------|----------------|
| Display | Language | | English German |

| Level 0 | Level 1 | Level 2 | Description |
|---------|---------------|---------|---|
| | Visibility | | Off Dark Normal Bright Dynamic |
| | Time Unit (s) | | (enter value) min = 1 max = 240 |

↪ Select **Display > Visibility**.

↪ Select **Display > Time Unit (s)**.

8.4.5 Changing the language

The system language can be configured with this configuration.

The structure of the configuration in the receiver control panel menu is as follows:

| Level 0 | Level 1 | Level 2 | Description |
|---------|------------|---------|--|
| Display | Language | | English German |
| | Visibility | | Off Dark Normal Bright Dynamic |
| | Time Unit | | (enter value) min = 1 max = 240 |

↪ Select **Display > English/German**.

8.4.6 Product information

With this configuration, you can read out product data (part number, type designation and other production-specific data) of the measuring light curtain.

The structure of the configuration in the receiver control panel menu is as follows:

| Level 0 | Level 1 | Level 2 | Description |
|-------------|-------------------|---------|---|
| Information | Product name | | CML 730i |
| | Product ID | | Receiver part no. (e.g., 50119835) |
| | Serial number | | Receiver serial number (e.g., 120950648) |
| | Tx.transmitter-ID | | Transmitter part no. (e.g., 50119407) |
| | Tx.transmitter-SN | | Transmitter serial number (e.g., 120950650) |
| | SW version | | E.g., 01.61 |
| | HW version | | E.g., A001 |
| | Kx version | | E.g., P01.30e |

↪ Select **Information**.

8.4.7 Resetting to factory settings

Factory settings can be restored with this configuration.

 The factory settings can also be restored via a control command in the used configuration software (e.g., IO-Link Device Tool).

The structure of this menu item in the receiver control panel menu is as follows:

| Level 0 | Level 1 | Level 2 | Description |
|----------------------|----------------|------------------|-------------------------|
| Main Settings | Mode | | Measurement operation |
| | Command | Teach Reset | Factory Settings |
| | Filter Depth | | (enter value) |

↩ Select **Main Settings > Command > Factory Settings**.

9 Starting up the device - Analog output

9.1 Analog output configuration on the receiver control panel

The configuration of the analog output involves the following steps on the receiver control panel.



The configurations can be performed via the receiver control panel or the IO-Link Device Tool (with connection to the PC). These configurations are stored in non-volatile memory so that they are retained the next time the device is switched on.

It is always the last-made settings which are active.

General prerequisites:

- The measuring light curtain has been mounted (see chapter 6 „Mounting and installation“) and connected ((see chapter 7)) correctly.
- The basic configuration has been performed (see chapter 8 „Starting up the device - Basic configuration“).

Configuration of analog signal, analog function, characteristic curve (start beam / end beam)

The following example shows the configuration of an analog output to 4 ... 20 mA. Current output pin 7 supplies an analog output signal depending on the first (FIB) interrupted beam. The measurement range goes from beam no. 1 ... 32.

Structure of the analog signal, analog function, characteristic curve (start beam, end beam) settings in the receiver control panel menu (multiple settings shown simultaneously):

| Level 0 | Level 1 | Level 2 | Description |
|---------------|-----------------|---------|--|
| Analog output | Analog signals | Off | U: 0 ... 5 V U: 0 ... 10 V U: 0 ... 11 V I: 4 ... 20 mA I: 0 ... 20 mA I: 0 ... 24 mA |
| | Analog function | Off | FIB FNIB LIB LNIB TIB TNIB |
| | Start Beam | | 001 |
| | End Beam | | 032 |

↪ Select the type of analog signal.

Not active, or a defined voltage level and/or current level.

↪ Select the type of analog function.

Not active or FIB; FNIB; LIB; LNIB; TIB; TNIB.

↪ Set the start of the characteristic curve.

The start of the characteristic curve is defined by the start beam.

↪ Set the end of the characteristic curve.

The end of the characteristic curve is defined by the end beam.

The analog-device-specific configuration is concluded. The CML is ready for measurement operation.

9.2 Analog output configuration via the IO-Link configuration interface

The configuration of the analog output involves the following steps in the configuration software from Leuze electronic (see chapter 14 „Connection to a PC“).



The configurations that are available in the IODD file via the configuration software from Leuze electronic (see chapter 14 „Connection to a PC“), can, in part, also be performed via the receiver control panel. Both configuration types are stored in non-volatile memory so that they are retained the next time the device is switched on.

It is always the last set configurations which are active. If the last changes to the configuration were made via the receiver control panel, any settings changed via, e.g., the control or PC are overwritten.

General prerequisites:

- The measuring light curtain has been mounted (see chapter 6 „Mounting and installation“) and connected (see chapter 7 „Electrical connection“) correctly.
- The measuring light curtain is connected to a PC via an IO-Link USB master (see chapter 14 „Connection to a PC“).
- The IO-Link device configuration software (incl. device-specific IODD file) is installed on the PC.
- The basic configuration has been performed (see chapter 8 „Starting up the device - Basic configuration“).



The IO-Link Device Description (IODD) can be used both with connected light curtain for direct configuration as well as without connected light curtain for creating device configurations.

An IODD file is supplied with the product. It can also be downloaded from the Internet.

↪ Open the configuration software.

↪ Configure the following parameters:

- Smoothing (definition of a beam number for which no object detection is yet detected)
- Type of analog signal (not active; or selection of defined voltage level and/or current level) (see chapter 9 „Starting up the device - Analog output“)
- Type of analog function (not active; or FIB; FNIB; LIB; LNIB; TIB; TNIB) (see chapter 9 „Starting up the device - Analog output“)
- Characteristic curve configuration (start beam and end beam) (see chapter 9 „Starting up the device - Analog output“)
- Filter depth (definition of a minimum number of measurement cycles after which beam evaluation is performed)

↪ If necessary, configure additional parameter/process data with the aid of the process data table (see chapter 10.3 „Parameter/process data for IO-Link“).

↪ Save the configuration in the light curtain.



After the IODD file has been transmitted from the PC to the CML, the updated configurations are active.

The IO-Link-specific configurations have been performed, copied to the CML and the CML is ready for measurement operation.

9.3 Behavior of the analog output

The output logic of the CML returns the output signals to the programmable logic control (PLC). On the X1 interface, two pins can be assigned as output for the analog control of the PLC process interface.

The selected beam area (start beam/end beam) is mapped to the analog output of the CML. The conversion is by means of a 12-bit D/A converter, whereby the 12-bit value (4096) is divided by the selected number of beams. The resulting values, mapped to the respective, configured analog values, yield the characteristic curve. If there are only a few beams, this results in an erratic characteristic curve.

i The beams used for the measurement can be freely defined from 1 to n via the receiver control panel. It is also possible to specify that only a part of the beam area be used for the measurement.

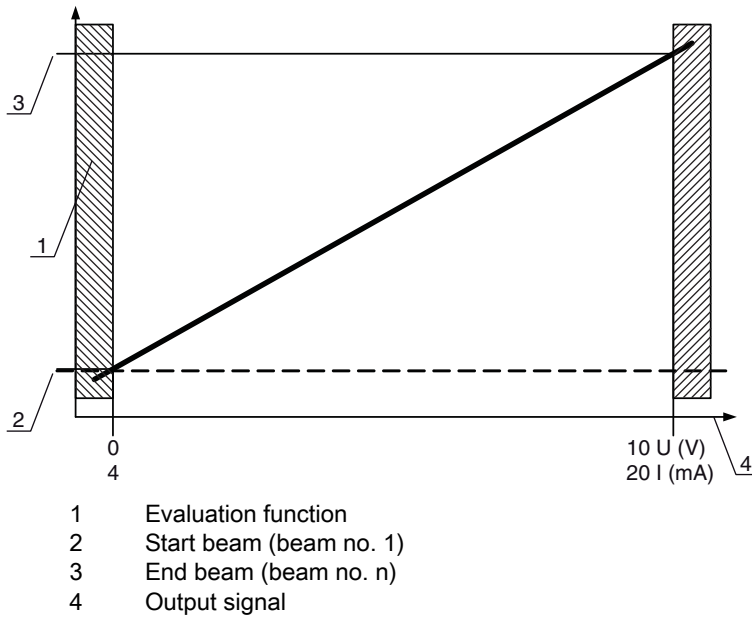

Figure 9.1: Characteristic curve of analog output (default)

If a higher beam number is selected for the beginning of the measurement range than for the end of the measurement range, the characteristic curve is inverted.

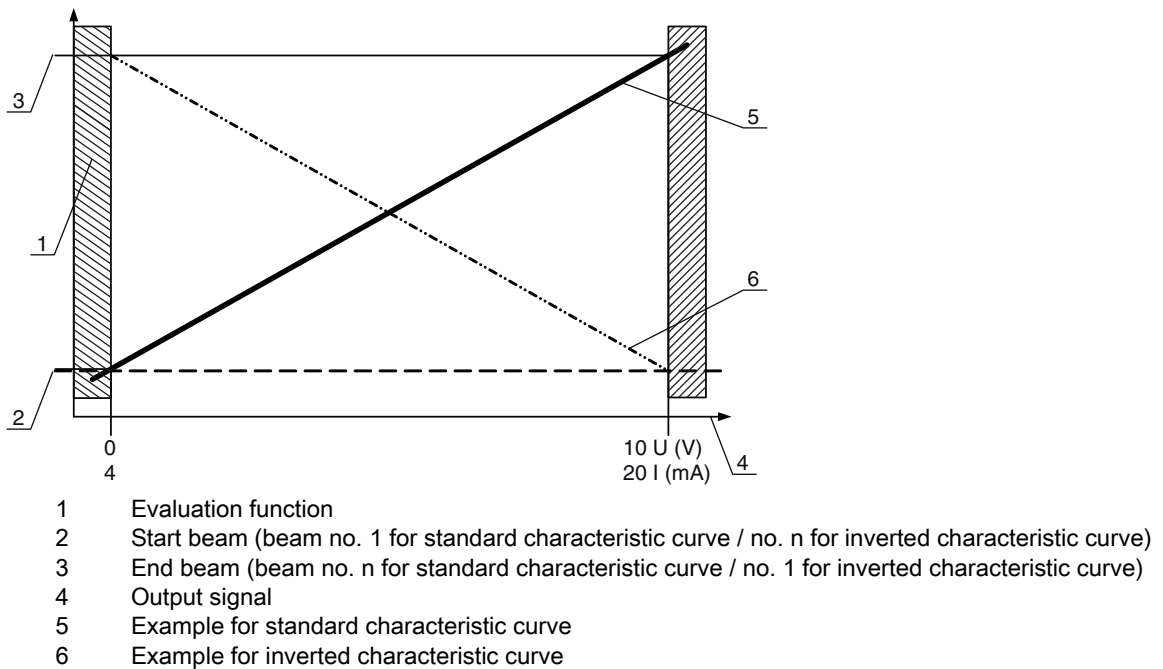

Figure 9.2: Characteristic curves of analog output

Overview: states of the analog output

| | | | |
|---|--|------------------------|---|
| Configuration for height and edge measurement | Analog value corresponding to the beam state | | |
| | All free | All or LIB interrupted | Half are free or one beam in middle is interrupted. |

| | | | | | |
|----------|---|---|---------------|---------------|-----------------|
| Standard | 1 | n | 4 mA | 20 (24) mA | 12 (14) mA |
| | | | 0 V | (5) 10 (11) V | (2.5) 5 (5.5) V |
| Inverted | n | 1 | 20 (24) mA | 4 mA | 12 (14) mA |
| | | | (5) 10 (11) V | 0 V | (2.5) 5 (5.5) V |

10 Starting up the device - IO-Link interface

The configuration of an IO-Link interface involves the following steps on the receiver control panel and in the configuration software of the used IO-Link master (e.g., IO-Link USB master from Leuze electronic, see chapter 14 „Connection to a PC“).



The configurations that are available in the IODD file via the configuration software from Leuze electronic (see chapter 14 „Connection to a PC“), can, in part, also be performed via the receiver control panel. Both configuration types are stored in non-volatile memory so that they are retained the next time the device is switched on.

It is always the last set configurations which are active. If the last changes to the configuration were made via the receiver control panel, any settings changed via, e.g., the control or PC are overwritten.

General prerequisites:

- The measuring light curtain has been mounted (see chapter 6 „Mounting and installation“) and connected (see chapter 7 „Electrical connection“) correctly.
- The basic configuration has been performed (see chapter 8 „Starting up the device - Basic configuration“).

10.1 Defining I/O-Link device configurations on the receiver control panel

The parameters for the IO-Link interface are configured with the baud rate and process data length (PD length) configurations.

The structure of these configurations in the receiver control panel menu is as follows:

| Level 0 | Level 1 | Level 2 | Description | |
|---------------|--------------|-----------|--|---------------------------------|
| Main Settings | Mode | | Measurement operation Alignment | |
| | Command | | Teach Reset Factory Settings | |
| | Filter Depth | | (enter value) | |
| | IO-Link | Baud rate | | COM3: 230.4 COM2: 38.4 |
| | | PD Length | | 32 bytes 8 bytes 2 bytes |

↪ Select **Main Settings > IO-Link > Baud rate**.

↪ Select **Main Settings > IO-Link > PD length**.

Possible additional configuration steps are performed within the configuration software from Leuze electronic.

10.2 Configurations on the IO-Link master module of the PLC

The configuration of an IO-Link interface involves the following steps in the configuration software of the IO-Link master module of the PLC (see chapter 14 „Connection to a PC“).

General prerequisites:

- The measuring light curtain has been mounted (see chapter 6 „Mounting and installation“) and connected (see chapter 7 „Electrical connection“) correctly.
- The basic configuration has been performed (see chapter 8 „Starting up the device - Basic configuration“).
- IO-Link-specific basic configurations have been performed.
 - IO-Link baud rate selected
 - IO-Link PD length selected



The IO-Link Device Description (IODD) can be used both with connected light curtain for direct configuration as well as without connected light curtain for creating device configurations.

An IODD file is supplied with the product. It can also be downloaded from the Internet.

| |
|---|
| NOTICE |
| Configuration dependent on the configuration software! |
| ↪ The sequence of the configurations is dependent on the specific configuration software. |

- ↪ Open the configuration software of the IO-Link master module.
- ↪ Configure the following parameters:
 - Operating mode (parallel-beam; diagonal-beam; crossed-beam)
 - Blanking areas
- ↪ Perform a teach.
- ↪ If necessary, configure additional parameter/process data (see chapter 10.3 „Parameter/process data for IO-Link“).
- ↪ Save the configuration.

The IO-Link-specific configurations have been performed, copied to the CML and the CML is ready for measurement operation.

10.3 Parameter/process data for IO-Link

In the standard design (factory setting), the light curtain cyclically transfers a data packet of 2 bytes at a baud rate of 38.4 k (COM2) to the IO-Link master module.

The parameter- and process data are described in the IO-Link Device Description (IODD) file.

Details on the parameters and on the structure of the process data can be found in the **.html** document, which is contained in the **IODD zip file**.

Overview

| Group 1 | Group name |
|----------|--|
| Group 1 | System commands |
| Group 2 | CML status information |
| Group 3 | Device description |
| Group 4 | General configurations |
| Group 5 | Extended settings |
| Group 6 | Process data settings |
| Group 7 | Cascading/trigger settings |
| Group 8 | Blanking settings |
| Group 9 | Teach settings |
| Group 10 | Digital IO Pin x Settings |
| Group 11 | Time module settings for digital outputs |
| Group 12 | Analog device settings |
| Group 13 | Autosplitting |
| Group 14 | Configuration for block evaluation of beam areas |
| Group 15 | Evaluation functions |

System commands (group 1)



Configured in module 3 “General configurations” are the type of scanning (parallel-/diagonal-/crossed-beam), counting direction and minimum object size for the evaluation (smoothing). The minimum hole size for the evaluation, e.g., in a web, is configured via inverted smoothing.

| Parameter | Index | Sub-index | Data type | Access | Value range | Default | Description |
|----------------|-------|-----------|------------------------|--------|--------------------|---------|--|
| System command | 2 | | unsigned integer 8 bit | WO | 128, 130, 162, 163 | 128 | 128: Reset device 130: Restore factory settings 162: Perform teach 163: Save settings |

| Parameter | Index | Sub-index | Data type | Access | Value range | Default | Description |
|----------------------------|-------|---------------------|--|--------|-------------|---------|--|
| Status of teach event | 69 | | unsigned integer 8 bit | RO | 0, 1, 128 | 0 | Status information on teach event 0: Teach successful 1: Teach running 128: Teaching error |
| Alignment | 70 | | record 32 bit, isolated access of sub-index not possible | RO | | | Information on the signal level of the first and last beam. The value changes depending on the selected performance reserve. |
| Signal level of last beam | 70 | 1 (bit offset = 16) | unsigned integer 16 bit | RO | | 0 | |
| Signal level of first beam | 70 | 2 (bit offset = 16) | unsigned integer 16 bit | RO | | 0 | |

CML status information (group 2)



The CML status information specifies operating state information or error messages.

| Parameter | Index | Sub-index | Data type | Access | Value range | Default | Description |
|------------------------|-------|-----------|-------------------------|--------|-------------|---------|---|
| CML status information | 162 | | unsigned integer 16 bit | RO | | | Operating state information or error messages |

Device description (group 3)



The device description specifies the device characteristics, e.g., beam spacing, number of physical / logical light axes, the number of cascades (16 individual beams) in the device and the cycle time.

| Parameter | Index | Sub-index | Data type | Access | Value range | Default | Description |
|-------------------|-------|-----------|-----------------|--------|-------------|---------|--------------------------------------|
| Manufacturer name | 16 | | string 32 bytes | RO | | | Leuze electronic GmbH + Co. KG |
| Manufacturer text | 17 | | string 64 bytes | RO | | | Leuze electronic - the sensor people |
| Product name | 18 | | string 64 bytes | RO | | | CML 730i |

| Parameter | Index | Sub-index | Data type | Access | Value range | Default | Description |
|-----------------------------------|-------|------------------------|---|--------|---------------|---------|--|
| Product ID | 19 | | string 64 bytes | RO | | | Receiver serial number: 9-digit number for unique product identification |
| Product text | 20 | | string 64 bytes | RO | | | |
| Serial number | 21 | | string 64 bytes | RO | | | |
| Hardware version | 22 | | string 16 bytes | RO | | | |
| Firmware version | 23 | | string 64 bytes | RO | | | |
| User-specific name | 24 | | string 32 bytes | RW | | | |
| Receiver part no. | 64 | | string 20 bytes | RO | | | Order number of the receiver (8-digit) |
| Transmitter product designation | 65 | | string 64 bytes | RO | | | Type designation |
| Transmitter part no. | 66 | | string 64 bytes | RO | | | Order number of the transmitter (8-digit) |
| Transmitter serial number | 67 | | string 64 bytes | RO | | | 9-digit number for unique product identification |
| Device characteristics | 68 | | record 80 bit, isolated access of sub-index not possible | RO | | | The device characteristics specify the beam spacing, the number of physical / logical light axes, the number of cascades (16 individual beams) in the device and the cycle time. |
| Beam spacing | 68 | 1 (bit offset = 64) | unsigned integer 16 bit | RO | 5, 10, 20, 40 | 5 | |
| Number of physical light axes | 68 | 2 (bit offset = 48) | unsigned integer 16 bit | RO | | 16 | |
| Number of configured logical axes | 68 | 3 (bit offset = 32) | unsigned integer 16 bit | RO | | 16 | |
| Number of optical cascades | 68 | 4 (bit offset = 16) | unsigned integer 16 bit | RO | | 1 | |
| Device cycle time | 68 | 5 (bit offset = 0) | unsigned integer 16 bit | RO | | 1000 | |

General configurations (group 4)



Configured under group 4 “General configurations” are the type of scanning (parallel-/diagonal-/crossed-beam), counting direction and minimum object size for the evaluation (smoothing). The minimum hole size for the evaluation, e.g., in a web, is configured via inverted smoothing.

| Parameter | Index | Sub-index | Data type | Access | Value range | Default | Description |
|---|-------|---------------------|--|--------|-------------|---------|---|
| General settings | 71 | | record 32 bit, isolated access of sub-index not possible | RW | | | |
| Mode | 71 | 1 (bit offset = 24) | unsigned integer 8 bit | RW | 0 ... 2 | 0 | 0: Parallel-beam scanning 1: Diagonal-beam scanning 2: Crossed-beam scanning |
| Counting direction | 71 | 2 (bit offset = 16) | unsigned integer 8 bit | RW | 0 ... 1 | 0 | 0: Normal - beginning at the connection side, 1: Inverted - beginning opposite the connection side |
| Smoothing - less than N interrupted beams are ignored | 71 | 3 (bit offset = 8) | unsigned integer 8 bit | RW | 1 ... 255 | | |
| Inverted smoothing - less than N free beams are ignored | 71 | 4 (bit offset = 0) | unsigned integer 8 bit | RW | 1 ... 255 | | |

Extended settings (group 5)



The extended settings specify the filter depth, integration time and button lock on the receiver control panel. The filter depth indicates the necessary number of consistent beam states before the evaluation of the measurement values; the measurement values are accumulated and retained over the duration of the integration time.

| Parameter | Index | Sub-index | Data type | Access | Value range | Default | Description |
|-------------------------|-------|---------------------|--|--------|-------------|---------|---|
| Extended settings | 74 | | record 32 bit, isolated access of sub-index not possible | RW | | | |
| Filter Depth | 73 | 2 (bit offset = 16) | unsigned integer 8 bit | RW | | 1 | |
| Integration time | 73 | 3 (bit offset = 0) | unsigned integer 8 bit | RW | | 0 | |
| Button lock and display | 78 | | unsigned integer 8 bit | RW | 0 ... 1 | 0 | Lock operational controls on the device. 0: Enabled 1: Locked |

Process data settings (group 6)



The process data settings describe the cyclically transmitted process data.

| Parameter | Index | Sub-index | Data type | Access | Value range | Default | Description |
|-------------------------------|-----------------------|-----------|---|--------|---|---------|--|
| Process data settings | 72 | | record 128 bit, isolated access of sub-index not possible | RW | | | |
| Evaluation function module 01 | 72 (bit offset = 120) | 1 | unsigned integer 8 bit | RW | 1 ... 111, 0, 200 ... 205, 208 ... 210, 212 | 0 | 1 ... 111: Number of optical cascades for beam-stream evaluation (16 beams) 0: No evaluation (NOP) 200: First interrupted beam (FIB) 201: First uninterrupted beam (FNIB) 202: Last interrupted beam (LIB) 203: Last uninterrupted beam (LNIB) 204: Number of interrupted beams (TIB) 205: Number of uninterrupted beams (TNIB) 208: Area Out - LoWord 209: Area Out - HiWord 210: Status of the digital inputs/outputs 212: CML status information |
| Evaluation function module 02 | 72 (bit offset = 112) | 2 | unsigned integer 8 bit | RW | 1 ... 111, 0, 200 ... 205, 208 ... 210, 212 | 0 | 1 ... 111: Number of optical cascades for beam-stream evaluation (16 beams) 0: No evaluation (NOP) 200: First interrupted beam (FIB) 201: First uninterrupted beam (FNIB) 202: Last interrupted beam (LIB) 203: Last uninterrupted beam (LNIB) 204: Number of interrupted beams (TIB) 205: Number of uninterrupted beams (TNIB) 208: Area Out - LoWord 209: Area Out - HiWord 210: Status of the digital inputs/outputs 212: CML status information |
| | | | | .. | .. | .. | |
| | | | | .. | .. | .. | |
| Evaluation function module 16 | 72 (bit offset = 0) | 1 | unsigned integer 8 bit | RW | 1 ... 111, 0, 200 ... 205, 208 ... 210, 212 | 0 | 1 ... 111: Number of optical cascades for beam-stream evaluation (16 beams) 0: No evaluation (NOP) 200: First interrupted beam (FIB) 201: First uninterrupted beam (FNIB) 202: Last interrupted beam (LIB) 203: Last uninterrupted beam (LNIB) 204: Number of interrupted beams (TIB) 205: Number of uninterrupted beams (TNIB) 208: Area Out - LoWord 209: Area Out - HiWord 210: Status of the digital inputs/outputs 212: CML status information |

Cascading/trigger settings (group 7)



To prevent mutual interference, multiple light curtains can be operated with a time offset with respect to one another (cascade). Here, the master generates the cyclical trigger signal; the slaves start their measurement after delay times, which are to be set to different values.

| Parameter | Index | Sub-index | Data type | Access | Value range | Default | Description |
|---|-------|---------------------|--|--------|---------------|---------|---|
| Trigger Settings | 73 | | record 64 bit, isolated access of sub-index not possible | RW | | 0 | |
| Cascading | 73 | 1 (bit offset = 56) | unsigned integer 8 bit | RW | 0 ... 1 | 0 | 0: Not active (constant measurement of the sensor) 1: Active (sensor expects trigger signal) |
| Function type | 73 | 2 (bit offset = 48) | unsigned integer 8 bit | RW | 0 ... 1 | 0 | 0: slave (expects trigger signal) 1: master (sends trigger signal) |
| Trigger delay time -> Start measurement | 73 | 3 (bit offset = 32) | unsigned integer 16 bit | RW | 500 ... 65535 | 0 | |
| Master cycle time | 73 | 3 (bit offset = 0) | unsigned integer 16 bit | RW | 1 ... 65535 | 0 | |

Blanking settings (group 8)



Up to 4 beam areas can be deactivated. Deactivated beams can be assigned the logical values 0, 1 or the value of the adjacent beam. With auto blanking activated, the selected area number (1 ... 4) is automatically suppressed during teaching.

| Parameter | Index | Sub-index | Data type | Access | Value range | Default | Description |
|-----------------------------------|-------|----------------------|---|--------|-------------|---------|--|
| Blanking settings | 76 | | record 208 bit, isolated access of sub-index not possible | RW | | | |
| Number of blanking areas | 76 | 1 (bit offset = 200) | unsigned integer 8 bit | RW | 0 ... 4 | 0 | |
| Auto blanking | 76 | 2 (bit offset = 192) | unsigned integer 8 bit | RW | 0 ... 1 | 0 | 0: Not active (manual blanking - area configuration) 1: Active (automatic area configuration through teach) |
| Logical value for blanking area 1 | 76 | 3 (bit offset = 176) | unsigned integer 16 bit | RW | 0 ... 4 | 0 | 0: No beams blanked 1: Logical value 0 for blanked beams 2: Logical value 1 for blanked beams 3: Logical value = same as adjacent beam with lower beam number 4: Logical value = same as adjacent beam with higher beam number |
| Start beam of blanking area 1 | 76 | 4 (bit offset = 160) | unsigned integer 16 bit | RW | 1 ... 1776 | 1 | |
| End beam of blanking area 1 | 76 | 5 (bit offset = 160) | unsigned integer 16 bit | RW | 1 ... 1776 | 1 | |

| Parameter | Index | Sub-index | Data type | Access | Value range | Default | Description |
|-----------------------------------|-------|-------------------------|----------------------------|--------|-------------|---------|--|
| Logical value for blanking area 2 | 76 | 6 (bit offset = 128) | unsigned integer 16 bit | RW | 0 ... 4 | 0 | 0: No beams blanked 1: Logical value 0 for blanked beams 2: Logical value 1 for blanked beams 3: Logical value = same as adjacent beam with lower beam number 4: Logical value = same as adjacent beam with higher beam number |
| Start beam of blanking area 2 | 76 | 7 (bit offset = 112) | unsigned integer 16 bit | RW | 1 ... 1776 | 1 | |
| End beam of blanking area 2 | 76 | 8 (bit offset = 96) | unsigned integer 16 bit | RW | 1 ... 1776 | 1 | |
| | | | | .. | .. | .. | |
| | | | | .. | .. | .. | |
| Logical value for blanking area 4 | 76 | 12 (bit offset = 32) | unsigned integer 16 bit | RW | 0 ... 4 | 0 | 0: No beams blanked 1: Logical value 0 for blanked beams 2: Logical value 1 for blanked beams 3: Logical value = same as adjacent beam with lower beam number 4: Logical value = same as adjacent beam with higher beam number |
| Start beam of blanking area 4 | 76 | 13 (bit offset = 16) | unsigned integer 16 bit | RW | 1 ... 1776 | 1 | |
| End beam of blanking area 4 | 76 | 14 (bit offset = 0) | unsigned integer 16 bit | RW | 1 ... 1776. | 1 | |

Teach settings (group 9)



In most applications, it is recommended that the teach values be stored in non-volatile memory. Depending on the performance reserve selected for the teach event, the sensitivity is higher or lower. Low performance reserve = high sensitivity.

| Parameter | Index | Sub-index | Data type | Access | Value range | Default | Description |
|--|-------|------------------------|---|--------|-------------|---------|---|
| Teach Settings | 79 | | record 32 bit, isolated access of sub-index not possible | RW | | 128 | |
| Type of storage for teach values | 79 | 2 (bit offset = 16) | unsigned integer 8 bit | RW | 0 ... 1 | 0 | 0: Non-volatile storage of teach values 1: Teach values stored only while voltage is ON |
| Sensitivity adjustment for teach event | 79 | 3 (bit offset = 8) | unsigned integer 8 bit | RW | 0 ... 3 | 0 | 0: High performance reserve for stable operation 1: Medium performance reserve 2: Low performance reserve 3: Transparent media |

Digital IO Pin x Settings (group 10)



In this group, the inputs/outputs can be set to positive switching (PNP) or to negative switching (NPN). The switching behavior applies the same for all inputs/outputs.

Moreover, the inputs/outputs can be configured via this group: pin 2 / 5 / 6 / 7 for IO-Link devices, pin 2 / 5 for analog or fieldbus devices.

| Parameter | Index | Sub-index | Data type | Access | Value range | Default | Description |
|---------------------------------------|-------|---------------------|--|--------|-------------|---------|---|
| Switching level of the inputs/outputs | 77 | | unsigned integer 8 bit | RW | 0 ... 1 | 1 | 0: Transistor, NPN 1: Transistor, PNP |
| Digital IO Pin 2 Settings | 80 | | record 32 bit, isolated access of sub-index not possible | RW | | | |
| Input/output selection | 80 | 1 (bit offset = 24) | unsigned integer 8 bit | RW | 0 ... 1 | 0 | 0: Output 1: Input |
| Switching behavior | 80 | 2 (bit offset = 16) | unsigned integer 8 bit | RW | 0 ... 1 | 0 | 0: Normal - light switching 1: Inverted - dark switching |
| Input function | 80 | 3 (bit offset = 8) | unsigned integer 8 bit | RW | 0 ... 2 | 0 | 0: Deactivated 1: Trigger input 2: Teach input |
| Output function | 80 | 4 (bit offset = 0) | unsigned integer 8 bit | RW | 0 ... 3 | 0 | 0: Deactivated 1: Switching output (area 1 ... 32) 2: Warning output 3: Trigger output |
| Area mapping 32 ... 1 (OR linked) | 84 | 3 (bit offset = 0) | unsigned integer 32 bit | RW | | 1 | |
| | | | | .. | .. | .. | |
| | | | | .. | .. | .. | |
| Digital IO Pin 7 Settings | 83 | | record 32 bit, isolated access of sub-index not possible | RW | | | |
| Input/output selection | 83 | 1 (bit offset = 24) | unsigned integer 8 bit | RW | 0 ... 1 | 0 | 0: Output 1: Input |
| Switching behavior | 83 | 2 (bit offset = 16) | unsigned integer 8 bit | RW | 0 ... 1 | 0 | 0: Normal - light switching 1: Inverted - dark switching |
| Input function | 83 | 3 (bit offset = 8) | unsigned integer 8 bit | RW | 0 ... 2 | 0 | 0: Deactivated 1: Trigger input 2: Teach input |
| Output function | 83 | 4 (bit offset = 0) | unsigned integer 8 bit | RW | 0 ... 3 | 0 | 0: Deactivated 1: Switching output (area 1 ... 32) 2: Warning output 3: Trigger output |
| Area mapping 32 ... 1 (OR linked) | 87 | 3 (bit offset = 0) | unsigned integer 32 bit | RW | | 1 | |

Time module settings for digital outputs (group 11)



Four different time functions can be configured in this group. The max. time duration that can be set is 65 s. Map output to areas 1 ... 32. Activate the area by entering a 1 at the corresponding position in the 32-bit word. Area 1 ... 32 increasing from right.

| Parameter | Index | Sub-index | Data type | Access | Value range | Default | Description |
|-----------------------------------|-------|---------------------|--|--------|-------------|---------|---|
| Digital Output Pin 2 Settings | 84 | | record 56 bit, isolated access of sub-index not possible | RW | | | |
| Operating mode of the time module | 84 | 1 (bit offset = 48) | unsigned integer 8 bit | RW | 0 ... 4 | 0 | 0: Deactivated 1: Start-up delay 2: Switch-off delay 3: Pulse stretching 4: Pulse suppression |
| Delay time for selected function | 84 | 2 (bit offset = 32) | unsigned integer 16 bit | RW | | 0 | |
| | | | | .. | .. | .. | |
| | | | | .. | .. | .. | |
| Digital Output Pin 7 Settings | 87 | | record 56 bit, isolated access of sub-index not possible | RW | | | |
| Operating mode of the time module | 87 | 1 (bit offset = 48) | unsigned integer 8 bit | RW | 0 ... 4 | 0 | 0: Deactivated 1: Start-up delay 2: Switch-off delay 3: Pulse stretching 4: Pulse suppression |
| Delay time for selected function | 87 | 2 (bit offset = 32) | unsigned integer 16 bit | RW | | 8 | |

Analog device settings (group 12)



In this group, various parameters can be used to set the analog device configurations, e.g, the configuration of the analog output level and how the evaluation function that is represented on the analog output is selected.

| Parameter | Index | Sub-index | Data type | Access | Value range | Default | Description |
|---|-------|---------------------|--|--------|-------------|---------|---|
| Signal level | 88 | | unsigned integer 8 bit | RW | 0 ... 6 | 0 | Configuration of the analog output level: voltage: 0-5 V voltage: 0-10 V voltage: 0-11 V current: 4-20 mA current: 0-20 mA current: 0-24 mA 0: Deactivated 1: Voltage: 0-5 V 2: Voltage: 0-10 V 3: Voltage: 0-11 V 4: Current: 4-20 mA 5: Current: 0-20 mA 6: Current: 0-24 mA |
| Evaluation function | 89 | | record 48 bit, isolated access of sub-index not possible | RW | | | Selection of the evaluation function that is represented on the analog output: first interrupted/uninterrupted beam (FIB/FNIB), last interrupted/uninterrupted beam (LIB/LNIB), number of interrupted/uninterrupted beams (TIB/TNIB) |
| Analog Function | 89 | 1 (bit offset = 40) | unsigned integer 8 bit | RW | 0 ... 6 | 0 | 0: No evaluation (NOP) 1: First interrupted beam (FIB) 2: First uninterrupted beam (FNIB) 3: Last interrupted beam (LIB) 4: Last uninterrupted beam (LNIB) 5: Number of interrupted beams (TIB) 6: Number of uninterrupted beams (TNIB) |
| Start beam for analog measurement range | 89 | 2 (bit offset = 16) | unsigned integer 16 bit | RW | 1 ... 1776 | 1 | |
| End beam for analog measurement range | 89 | 3 (bit offset = 16) | unsigned integer 16 bit | RW | 1 ... 1776 | 1 | |

Autosplitting (group 13)



In this group, it is possible to split all physically present beams into areas of identical size. The fields of areas 01 ... 32 are thereby automatically configured.

| Parameter | Index | Sub-index | Data type | Access | Value range | Default | Description |
|-------------------------------------|-------|--------------------|--|--------|-------------|---------|--|
| Splitting | 98 | | record 16 bit, isolated access of sub-index not possible | RW | | | Splitting of all physically present beams into areas of identical size according to the number of areas set under "number of areas". The fields of areas 01 ... 32 are thereby automatically configured. |
| Evaluation of the beams in the area | 98 | 1 (bit offset = 8) | unsigned integer 8 bit | RW | 0 ... 1 | 0 | 0: OR combination 1: AND combination |
| Number of areas (evenly split) | 98 | 2 (bit offset = 0) | unsigned integer 8 bit | RW | 1 ... 32 | 1 | |

Configuration for block evaluation of beam areas (group 14)



In this group, a detailed area configuration can be displayed and a beam area configured for the block evaluation.

| Parameter | Index | Sub-index | Data type | Access | Value range | Default | Description |
|-------------------------------------|-------|----------------------|---|--------|--|---------|--|
| Display detailed area configuration | 99 | | unsigned integer 8 bit | RW | 0 ... 32 | 0 | Select the desired area (1 ... 32) for which the configuration is to be edited in detail. 0: Area 01 1: Area 02 2: Area 03 ... 31: Area 32 |
| Configuration of area 01 | 100 | | record 112 bit, isolated access of sub-index not possible | RW | | | Configuration of the area: definition of the status conditions so that the area takes on a logical 1 or 0. For diagonal- or crossed-beam mode, the numbers of the logical beams are to be entered. |
| Area | 100 | 1 (bit offset = 104) | unsigned integer 8 bit | RW | 0 ... 1 | 0 | 0: Deactivated 1: Activated |
| Logical behavior of the area | 100 | 2 (bit offset = 96) | unsigned integer 8 bit | RW | 0 ... 1 | 0 | 0: Normal - light switching 1: Inverted - dark switching |
| Start beam of the area | 100 | 3 (bit offset = 80) | unsigned integer 16 bit | RW | 1 ... 1776 65534 65533 65532 65531 | 1 | 65534: First interrupted beam (FIB) 65533: First uninterrupted beam (FNIB) 65532: Last interrupted beam (LIB) 65531: Last uninterrupted beam (LNIB) |
| End beam of the area | 100 | 4 (bit offset = 64) | unsigned integer 16 bit | RW | 1 ... 1776 65534 65533 65532 65531 | 1 | 65534: First interrupted beam (FIB) 65533: First uninterrupted beam (FNIB) 65532: Last interrupted beam (LIB) 65531: Last uninterrupted beam (LNIB) |
| Number of active beams for area ON | 100 | 5 (bit offset = 48) | unsigned integer 16 bit | RW | 0 ... 1776 | 0 | |
| Number of active beams for area OFF | 100 | 6 (bit offset = 32) | unsigned integer 16 bit | RW | 0 ... 1776 | 0 | |
| Specified middle of the area | 100 | 7 (bit offset = 16) | unsigned integer 16 bit | RW | 0 ... 1776 | 0 | |
| Specified width of the area | 100 | 8 (bit offset = 0) | unsigned integer 16 bit | RW | 0 ... 1776 | 0 | |
| | | | | .. | .. | .. | |
| | | | | .. | .. | .. | |
| Configuration of area 32 | 131 | | record 112 bit, isolated access of sub-index not possible | RW | | | Configuration of the area: definition of the status conditions so that the area takes on a logical 1 or 0. For diagonal- or crossed-beam mode, the numbers of the logical beams are to be entered. |
| Area | 131 | 1 (bit offset = 104) | unsigned integer 8 bit | RW | 0 ... 1 | 0 | 0: Deactivated 1: Activated |
| Logical behavior of the area | 131 | 2 (bit offset = 96) | unsigned integer 8 bit | RW | 0 ... 1 | 0 | 0: Normal - light switching 1: Inverted - dark switching |

| Parameter | Index | Sub-index | Data type | Access | Value range | Default | Description |
|-------------------------------------|-------|------------------------|----------------------------|--------|-------------|---------|-------------|
| Start beam of the area | 131 | 3 (bit offset = 80) | unsigned integer 16 bit | RW | 1 ... 65534 | 1 | |
| End beam of the area | 131 | 4 (bit offset = 64) | unsigned integer 16 bit | RW | 1 ... 65534 | 1 | |
| Number of active beams for area ON | 131 | 5 (bit offset = 48) | unsigned integer 16 bit | RW | 1 ... 1776 | 0 | |
| Number of active beams for area OFF | 131 | 6 (bit offset = 32) | unsigned integer 16 bit | RW | 1 ... 1776 | 0 | |
| Specified middle of the area | 131 | 7 (bit offset = 16) | unsigned integer 16 bit | RW | 1 ... 1776 | 0 | |
| Specified width of the area | 131 | 8 (bit offset = 0) | unsigned integer 16 bit | RW | 1 ... 1776 | 0 | |

Evaluation functions (group 15)



In this group, all evaluation functions can be configured.

| Parameter | Index | Sub-index | Data type | Access | Value range | Default | Description |
|--------------------------------------|-------|-----------|----------------------------|--------|-------------|---------|--|
| First interrupted beam (FIB) | 150 | | unsigned integer 16 bit | RO | | | Logical beam number of the first darkened light axis. The logical beam numbers change in diagonal- or crossed-beam mode. Note any changed configuration of the counting direction! |
| First uninterrupted beam (FNIB) | 151 | | unsigned integer 16 bit | RO | | | Logical beam number of the first undarkened light axis. The logical beam numbers change in diagonal- or crossed-beam mode. Note any changed configuration of the counting direction! |
| Last interrupted beam (LIB) | 152 | | unsigned integer 16 bit | RO | | | Logical beam number of the last darkened light axis. The logical beam numbers change in diagonal- or crossed-beam mode. Note any changed configuration of the counting direction! |
| Last uninterrupted beam (LNIB) | 153 | | unsigned integer 16 bit | RO | | | Logical beam number of the last undarkened light axis. The logical beam numbers change in diagonal- or crossed-beam mode. Note any changed configuration of the counting direction! |
| Number of interrupted beams (TIB) | 154 | | unsigned integer 16 bit | RO | | | Sum of all darkened light axes. The sum changes in diagonal- or crossed-beam mode. |
| Number of uninterrupted beams (TNIB) | 155 | | unsigned integer 16 bit | RO | | | Sum of all undarkened light axes. The sum changes in diagonal- or crossed-beam mode. |
| Area Out - LoWord | 158 | | unsigned integer 16 bit | RO | | | Status of areas 01-16 as 2 bytes of process data |
| Area Out - HiWord | 159 | | unsigned integer 16 bit | RO | | | Status of areas 17-32 as 2 bytes of process data |
| Status of the digital inputs/outputs | 160 | | unsigned integer 16 bit | RO | | | Status of the 2 or 4 digital inputs or outputs |

| Parameter | Index | Sub-index | Data type | Access | Value range | Default | Description |
|-----------------|-------|-----------|-------------------------|--------|-------------|---------|-------------|
| HW analog (HWA) | 161 | | unsigned integer 16 bit | RO | | | |
| PD BeamStream | 171 | | array | RO | | | 8 bytes |
| PD BeamStream | 172 | | array | RO | | | 16 bytes |
| PD BeamStream | 173 | | array | RO | | | 32 bytes |
| PD BeamStream | 172 | | array | RO | | | 64 bytes |
| PD BeamStream | 172 | | array | RO | | | 128 bytes |

11 Starting up the device - CANopen fieldbus interface

The configuration of a CANopen fieldbus interface involves the following steps on the receiver control panel and in the fieldbus-specific configuration software.



The configurations that are available in the EDS file via the fieldbus-specific configuration software can, in part, also be performed via the receiver control panel. Both configuration types are stored in non-volatile memory so that they are retained the next time the device is switched on.

It is always the last set configurations which are active. If the last changes to the configuration were made via the receiver control panel, any settings changed via, e.g., the control or PC are overwritten.

General prerequisites:

- The measuring light curtain has been mounted (see chapter 6 „Mounting and installation“) and connected (see chapter 7 „Electrical connection“) correctly.
- The basic configuration has been performed (see chapter 8 „Starting up the device - Basic configuration“).

11.1 Defining the CANopen basic configuration on the receiver control panel

The parameters for the CANopen interface are defined with the node ID and baud rate configurations. The structure of these configurations in the receiver control panel menu is as follows:

| Level 1 | Level 2 | Description |
|--------------|-----------|---|
| Mode | | Measurement oper- Alignment ation |
| Command | | Teach Reset Factory Settings |
| Filter Depth | | (enter value) |
| CANopen | Node ID | (enter value) min = 1 max = 127 |
| | Baud rate | 1000 kBaud 500 kBaud 250 kBaud 125 kBaud |

Prerequisites:

- The measuring light curtain must be correctly aligned (see chapter 8.1 „Aligning transmitter and receiver“).
- The measuring light curtain must be correctly taught (see chapter 8.2 „Teaching the environmental conditions“).

The following procedure describes the configurations for CANopen interfaces.

☞ Select **Main Settings > CANopen > Node ID**.

☞ Select **Main Settings > CANopen > Baud rate**.

The CANopen address (Node ID) and baud rate have been configured.

Possible additional configuration steps are performed within the configuration software for the fieldbus-specific interface.

11.2 Configurations with the fieldbus-specific software

General prerequisites:

- The measuring light curtain has been mounted (see chapter 6 „Mounting and installation“) and connected (see chapter 7 „Electrical connection“) correctly.
- The fieldbus-specific configuration software has been installed on the PC.
- The basic configuration has been performed (see chapter 8 „Starting up the device - Basic configuration“).
- The CANopen basic configurations have been performed:

- CANopen node ID selected
- CANopen baud rate selected

Specific prerequisites:

- The CANopen-specific EDS file must be installed on the PC.



The CANopen Device Description (EDS) can be used both with connected light curtain for direct configuration as well as without connected light curtain for creating device configurations.

An EDS file is supplied with the product. It can also be downloaded from the Internet at www.leuze.com.

NOTICE

Configuration dependent on the fieldbus-specific software!

- ↪ The sequence of the configurations is dependent on the fieldbus-specific software.
- ↪ First configure the EDS file while off-line.
- ↪ Once all parameters have been configured, transmit them to the CML.



Information on using the configuration parameters can be found in the general descriptions of the individual functions of the CML (see chapter 4 „Functions“).

- ↪ Open the interface configuration software.
- ↪ Configure the following configuration parameters:
 - Operating mode (parallel-beam; diagonal-beam; crossed-beam)
 - Blanking areas
- ↪ Perform a teach.
- ↪ If necessary, configure additional parameter/process data (see chapter 11.3 „Parameter/process data for CANopen“).
- ↪ Save the configuration.

The CANopen-specific configurations have been performed and the CML is ready for measurement operation.

11.3 Parameter/process data for CANopen

The configuration parameters or process data for CANopen is defined via the following object descriptions.

NOTICE

Boundary conditions for object descriptions!

- ↪ The CML light curtains communicate according to the specifications for CANopen profiles “DS301” and “DS401”.
- ↪ Indices 1000 -1FFF contain the standard communication-specific parameters used with CANopen.
- ↪ The product-specific parameters begin with index 2000.
- ↪ Communication-specific parameters are automatically persistent.
- ↪ In order for product-specific parameters to be retained following a power down/up, a save command (index 0x2200) is necessary.



The following **abbreviations for data types** apply in the following module descriptions:

t08U = type 8 bit unsigned integer

t08S = type 8 bit signed integer

t16U = type 16 bit unsigned integer

t16S = type 16 bit signed integer



The following **abbreviations for max. values** apply in the following module descriptions:

MAX-BEAM = maximum number of beams

MAX_T08U = maximum 8 bit unsigned integer

MAX_T16U = maximum 16 bit unsigned integer

MAX_T32U = maximum 32 bit unsigned integer

Module overview

| Module | Module name |
|-----------|---|
| Module 1 | CANopen-specific objects |
| Module 2 | Device description |
| Module 3 | General configurations |
| Module 4 | Cascading configuration |
| Module 5 | Teach settings |
| Module 6 | Blanking settings |
| Module 7 | Switching level of the inputs/outputs |
| Module 8 | Area configuration |
| Module 9 | Commands |
| Module 10 | Teach status |
| Module 11 | Check the alignment of the light curtains |
| Module 12 | Process data |
| Module 13 | Status |

CANopen-specific objects (module 1)

| Parameter | Index (hex) | Sub-index (hex) | Data type | Access | Min. value | Max. value | Default | Description |
|----------------|-------------|-----------------|-----------|--------|------------|------------|----------------|-------------|
| Device Type | 1000 | | | RO | | | 0x008 B0191 | |
| Error Register | 1001 | | | RO | | | | |
| COB-ID-SYNC | 1005 | | | RW | | | 0x000 00080 | |

| Parameter | Index (hex) | Sub-index (hex) | Data type | Access | Min. value | Max. value | Default | Description |
|-------------------------------|-------------|-----------------|-----------|--------|------------|------------|---------|-----------------------------------|
| Receiver product designation | 1008 | | | CONST | | | | |
| Hardware revision | 1009 | | | CONST | | | | |
| Software revision | 100A | | | CONST | | | | |
| Producer heartbeat time | 1017 | | | RW | | | 0 | Necessary for heartbeat mechanism |
| PDO_COMMUNICATION_PARAMETER_1 | 1800 | | | RW | | | | PDO 1 properties |
| PDO_COMMUNICATION_PARAMETER_2 | 1801 | | | RW | | | | PDO 2 properties |
| PDO_COMMUNICATION_PARAMETER_3 | 1802 | | | RW | | | | PDO 3 properties |
| PDO_COMMUNICATION_PARAMETER_4 | 1803 | | | RW | | | | PDO 4 properties |
| PDO_MAPPING_PARAMETER_1 | 1A00 | | t32U | RW | | | | Mapped objects in PDO 1 |
| PDO_MAPPING_PARAMETER_2 | 1A01 | | t32U | RW | | | | Mapped objects in PDO 2 |
| PDO_MAPPING_PARAMETER_3 | 1A02 | | t32U | RW | | | | Mapped objects in PDO 3 |
| PDO_MAPPING_PARAMETER_4 | 1A03 | | t32U | RW | | | | Mapped objects in PDO 4 |



The following standard procedure for the TPDO mapping may vary depending on the used configuration software.

Standard procedure for the TPDO mapping:

- ↵ Set the device to the “Preoperational” state.
- ↵ In the desired TPDO 1 ... 4 (objects 1800 ... 1803 “PDO Mapping Entry”), set the COB-ID (sub-index 1) to 0x80000xxx (where the xxx part is node-dependent) and transmit this COB-ID to the device.
This sets the invalid bit, thereby making the TPDO entry invalid.
- ↵ In the desired TPDO mapping entry (objects 1A00 ... 1A03 “PD 01 to PD 04”), set the entry for the number of following elements (sub-index 0, “numOfEntries”) to 0 and transmit this to the device.
An existing mapping is thereby deleted.
- ↵ Then reset this entry to the number of desired mapping elements, whereby a maximum of 4 elements are possible.
Transmit this entry back to the device.
- ↵ Set the mapping entries to the desired values. Each of the mapping sub-indices contains a 32-bit value that is structured as follows: SDO object number, sub-index and length. Normally (depending on the used master), the respective settings can be selected from a list.
- ↵ After completing the mapping, transmit the complete TPDO mapping object to the device.
- ↵ In the TPDO object (objects 1800-1803 “PDO Mapping Entry”), set the transmission type (sub-index 2 “Transmission Type”) and, if applicable, the event timer (sub-index 5, “Event Timer”).
- ↵ In the same TPDO object, set the COB-ID (sub-index 1) to 0x00000xxx (where the xxx part is node-dependent) and transmit the complete TPDO object including all sub-indices to the device. This sets the valid bit, thereby making the TPDO entry valid.
- ↵ Set the device to the “Operational” state.
Depending on the set operating mode, the device will then begin to send PDOs.

Device description (module 2)



The device characteristics, beginning with index 200B, specify the beam spacing, the number of physical / logical light axes, the number of cascades (16 individual beams) in the device and the cycle time.

| Parameter | Index (hex.) | Sub-index (hex) | Data type | Access | Min. value | Max. value | Default | Description |
|---------------------------------------|--------------|-----------------|-----------|--------|------------|------------|---------|--|
| Vendor Name | 2000 | | | RO | | | | Leuze electronic |
| Manufacturer text | 2001 | | | RO | | | | The sensor people |
| Receiver part no. | 2002 | | | RO | | | | Receiver |
| Receiver serial number | 2003 | | | RO | | | | Receiver |
| Transmitter product designation | 2008 | | | RO | | | | Transmitter |
| Transmitter part no. | 2009 | | | RO | | | | Transmitter |
| Transmitter serial number | 200A | | | RO | | | | Transmitter |
| Beam spacing | 200B | 1 | t16U | RO | | | | |
| Number of physical light axes | 200B | 2 | t16U | RO | | | | |
| Number of configured logical cascades | 200B | 3 | t16U | RO | | | | With parallel scanning, the number of logical axes corresponds to the number of physical axes; with diagonal scanning, this number is doubled. |
| Number of optical cascades | 200B | 4 | t16U | RO | | | | |
| Device cycle time [µs] | 200B | 5 | t16U | RO | | | | Duration for a complete measurement cycle (measurement cycle for one measurement); minimum time is 1 ms |

General configurations (module 3)



Configured in module 3 “General configurations” are the type of scanning (parallel-/diagonal-/crossed-beam), counting direction and minimum object size for the evaluation (smoothing). The minimum hole size for the evaluation, e.g., in a web, is configured via inverted smoothing.

| Parameter | Index (hex.) | Sub-index (hex) | Data type | Access | Min. value | Max. value | Default | Description |
|--------------------|--------------|-----------------|-----------|--------|------------|------------|---------|---|
| Mode | 2100 | 1 | t08U | RW | 0 | 3 | 0 | 0: Parallel-beam scanning 1: Diagonal-beam scanning 2: Crossed-beam scanning |
| Counting direction | 2100 | 2 | t08U | RW | 0 | 1 | 0 | 0: Normal – beginning at the connection side, 1: Inverted – beginning opposite the connection side |
| Smoothing | 2100 | 3 | t08U | RW | 1 | MAX_T08U | 1 | Less than n interrupted beams are ignored |
| Smoothing inverted | 2100 | 4 | t08U | RW | 1 | MAX_T08U | 1 | Less than n free beams are ignored |



The filter depth indicates the necessary number of consistent beam states before the evaluation of the measurement values.

All measurement values are accumulated and retained over the duration of the integration time.

| Parameter | Index (hex.) | Sub-index (hex) | Data type | Access | Min. value | Max. value | Default | Description |
|-------------------------|--------------|-----------------|-----------|--------|------------|------------|---------|---|
| | 2101 | 1 | t08U | RO | 0 | | | Reserved |
| Filter Depth | 2101 | 2 | t08U | RW | 0 | MAX_T08U | 1 | The necessary number of consistent beam states before the evaluation of the measurement values. |
| Integration / hold time | 2101 | 3 | T16U | RW | 0 | MAX_T16U | 0 | Hold function in ms All measurement values are accumulated and retained over the duration of the integration time. |

Cascading configuration (module 4)



To prevent mutual interference, multiple light curtains can be operated with a time offset with respect to one another (cascade). Here, the master generates the cyclical trigger signal; the slaves start their measurement after delay times, which are to be set to different values.

| Parameter | Index (hex.) | Sub-index (hex) | Data type | Access | Min. value | Max. value | Default | Description |
|--|--------------|-----------------|-----------|--------|------------|------------|---------|--|
| Cascading | 2102 | 1 | t08U | RW | | 1 | 0 | 0: Not active (constant measurement of the sensor) 1: Active (sensor expects trigger signal) Notice: With cascading operation, the master must also be set to 1 (active)! |
| Function type | 2102 | 2 | t08U | RW | | 1 | 0 | 0: slave (expects trigger signal) 1: master (sends trigger signal) |
| Trigger delay time -> Start of measurement | 2102 | 3 | T16U | RW | | MAX_T16U | 500 | Delay time in µs (from rising edge at TRIGGER until start of measurement cycle) |
| Pulse width of the trigger signal | 2102 | 4 | T16U | RO | | | 100 | Pulse width of the master trigger in µs (for information only) |
| Master cycle time | 2102 | 5 | T16U | RW | | 6500 | 1 | Duration of a TRIGGER_cycle in ms |

Teach settings (module 5)



In most applications, it is recommended that the teach values be stored in non-volatile memory. Depending on the performance reserve selected for the teach event, the sensitivity is higher or lower. Low performance reserve = high sensitivity.

| Parameter | Index (hex.) | Sub-index (hex) | Data type | Access | Min. value | Max. value | Default | Description |
|--|--------------|-----------------|-----------|--------|------------|------------|---------|---|
| Number of teach cycles | 2103 | 1 | t08U | RO | | | 10 | Depending on the environmental conditions or application, the light curtain may have completed multiple cycles after the triggering of a teach. |
| Type of storage for teach values | 2103 | 2 | t08U | RW | 0 | 1 | 0 | 0: Non-volatile storage of teach values 1: Teach values stored only while voltage is ON |
| Sensitivity adjustment for teach event | 2103 | 3 | t08U | RW | 0 | 2 | 0 | 0: High performance reserve for stable operation 1: Medium performance reserve 2: Low performance reserve |
| Teach status | 2400 | 1 | t08S | RO | 0 | MAX_T08U | | Information about the last teach. 0x00: Teach ok 0x01: Teach busy 0x80: Teach error (bit8 = error bit) |

Blanking Settings (module 6)



Up to 4 beam areas can be deactivated. Deactivated beams can be assigned the logical values 0, 1 or the value of the adjacent beam. With auto blanking activated, the selected area number (1-4) is automatically suppressed during teaching.

For details on this topic see chapter 13.4 „Example configuration - activating and deactivating blanking areas“.

| Parameter | Index (hex.) | Sub-index (hex) | Data type | Access | Min. value | Max. value | Default | Description |
|---------------------------------|--------------|-----------------|-----------|--------|------------|------------|---------|--|
| Number of auto-blanking areas | 2104 | 1 | t08U | RW | 0 | 4 | 0 | Permissible number of blanking areas during automatic teaching |
| Auto blanking (during teaching) | 2104 | 2 | t08U | RW | 0 | 1 | 0 | 0: Not active (manual blanking-area configuration) 1: Active (automatic blanking-area configuration through teach) |
| Function for blanking area 1 | 2104 | 3 | t16U | RW | 0 | 4 | 0 | 0: No beams blanked 1: Logical value 0 for blanked beams 2: Logical value 1 for blanked beams 3: Logical value = same as adjacent beam with lower beam number 4: Logical value = same as adjacent beam with higher beam number |
| Start beam of blanking area 1 | 2104 | 4 | t16U | RW | 1 | MAX_BEAM | 1 | Start beam of the blanking area |
| End beam of blanking area 1 | 2104 | 5 | t16U | RW | 1 | MAX_BEAM | 1 | End beam of the blanking area |
| Function for blanking area 2 | 2104 | 6 | t16U | RW | 0 | 4 | 0 | 0: No beams blanked 1: Logical value 0 for blanked beams 2: Logical value 1 for blanked beams 3: Logical value = same as adjacent beam with lower beam number 4: Logical value = same as adjacent beam with higher beam number |

| Parameter | Index (hex.) | Sub-index (hex) | Data type | Access | Min. value | Max. value | Default | Description |
|-------------------------------|--------------|-----------------|-----------|--------|------------|------------|---------|--|
| Start beam of blanking area 2 | 2104 | 7 | t16U | RW | 1 | MAX_BEAM | 1 | Start beam of the blanking area |
| End beam of blanking area 2 | 2104 | 8 | t16U | RW | 1 | MAX_BEAM | 1 | End beam of the blanking area |
| Function for blanking area 3 | 2104 | 9 | t16U | RW | 0 | 4 | 0 | 0: No beams blanked 1: Logical value 0 for blanked beams 2: Logical value 1 for blanked beams 3: Logical value = same as adjacent beam with lower beam number 4: Logical value = same as adjacent beam with higher beam number |
| Start beam blanking area 3 | 2104 | A | t16U | RW | 1 | MAX_BEAM | 1 | Start beam of the blanking area |
| End beam of blanking area 3 | 2104 | B | t16U | RW | 1 | MAX_BEAM | 1 | End beam of the blanking area |
| Function for blanking area 4 | 2104 | C | t16U | RW | 0 | 4 | 0 | 0: No beams blanked 1: Logical value 0 for blanked beams 2: Logical value 1 for blanked beams 3: Logical value = same as adjacent beam with lower beam number 4: Logical value = same as adjacent beam with higher beam number |
| Start beam of blanking area 4 | 2104 | D | t16U | RW | 1 | MAX_BEAM | 1 | Start beam of the blanking area |
| End beam of blanking area 4 | 2104 | E | t16U | RW | 1 | MAX_BEAM | 1 | End beam of the blanking area |

Switching level of the inputs/outputs (module 7)



The inputs/outputs can be set to positive switching (PNP) or to negative switching (NPN). The switching behavior applies the same for all inputs/outputs.

For details on this topic see chapter 13 „Example configurations“.

| Parameter | Index (hex.) | Sub-index (hex) | Data type | Access | Min. value | Max. value | Default | Description |
|---------------|--------------|-----------------|-----------|--------|------------|------------|---------|------------------|
| Type of level | 2150 | | Bool | RW | 0 | 1 | 1 | 0: NPN 1: PNP |



Configuration of the inputs/outputs: pin 2 and/or pin 5.

| Parameter | Index (hex.) | Sub-index (hex) | Data type | Access | Min. value | Max. value | Default | Description |
|----------------------------------|--------------|-----------------|-----------|--------|------------|------------|---------|---|
| Configuration of pin 2 | | | | | | | | |
| Pin 2: Output function | 2151 | 1 | t08U | RW | 0 | 3 | 0 | 0: Deactivated 1: Switching output (area 1 ... 32) 2: Warning output 3: Trigger output |
| Pin 2: Input function | 2151 | 2 | t08U | RW | 0 | 2 | 2 | 0: Deactivated 1: Trigger input 2: Teach input |
| Pin 2: Switching behavior | 2151 | 3 | t08U | RW | 0 | 1 | 0 | 0: Normal - light switching 1: Inverted - dark switching |
| Pin 2: Input/output selection | 2151 | 4 | t08U | RW | 0 | 1 | 1 | 0: Output 1: Input |
| Configuration of pin 5 | | | | | | | | |
| Pin 5: Output function | 2152 | 1 | t08U | RW | 0 | 3 | 0 | 0: Deactivated 1: Switching output (area 1 ... 32) 2: Warning output 3: Trigger output |
| Pin 5: Input function | 2152 | 2 | t08U | RW | 0 | 2 | 1 | 0: Deactivated 1: Trigger input 2: Teach input |
| Pin 5: Switching behavior | 2152 | 3 | t08U | RW | 0 | 1 | 0 | 0: Normal - light switching 1: Inverted - dark switching |
| Pin 5: Input/output selection | 2152 | 4 | t08U | RW | 0 | 1 | 1 | 0: Output 1: Input |

Procedure for the four time ranges:

Four different time functions can be set; the maximum duration that can be set is 65 s.

Mapping of an area 1-32 to output pin 2 = index 2155 sub 3 or index 2156 sub 3 for pin 5.

↳ Activate the area by entering a 1 at the corresponding position in the 32-bit word. Area 1 ... 32 increasing from right.



For details on this topic see chapter 13 „Example configurations“.

| Parameter | Index (hex.) | Sub-index (hex) | Data type | Access | Min. value | Max. value | Default | Description |
|--------------------------------------|--------------|-----------------|-----------|--------|------------|------------|---------|---|
| Digital Output Pin 2 Settings | | | | | | | | |
| Operating mode of the time module | 2155 | 1 | t08U | RW | 0 | 4 | 0 | 0: Deactivated 1: Start-up delay 2: Switch-off delay 3: Pulse stretching 4: Pulse suppression |
| Delay time for selected function | 2155 | 2 | t16U | RW | 0 | MAX_T16U | 0 | 0 ... 65535 ms |
| Area mapping 32 ... 1 | 2155 | 3 | t32U | RW | 0 | MAX_T32U | 0 | Logical OR link mask of the switching outputs |
| Digital Output Pin 5 Settings | | | | | | | | |

| Parameter | Index (hex.) | Sub-index (hex) | Data type | Access | Min. value | Max. value | Default | Description |
|-----------------------------------|--------------|-----------------|-----------|--------|------------|------------|---------|---|
| Operating mode of the time module | 2156 | 1 | t08U | RW | 0 | 4 | 0 | 0: Deactivated 1: Start-up delay 2: Switch-off delay 3: Pulse stretching 4: Pulse suppression |
| Delay time for selected function | 2156 | 2 | t16U | RW | 0 | MAX_T16U | 0 | 0 ... 65535 ms |
| Area mapping 32 ... 1 | 2156 | 3 | t32U | RW | 0 | MAX_T32U | 0 | Logical OR link mask of the switching outputs |

Area configuration (module 8)

Procedure for manual area splitting of the maximum 32 areas:

↳ Definition of the status conditions so that the area takes on a logical 1 or 0.

For diagonal- or crossed-beam mode, the numbers of the logical beams are to be entered.



For details on this topic see chapter 13 „Example configurations“.

| Parameter | Index (hex.) | Sub-index (hex) | Data type | Access | Min. value | Max. value | Default | Description |
|-------------------------------------|--------------|-----------------|-----------|--------|------------|------------|---------|--|
| Configuration of area 1 | 2170 | | | | | | | |
| Area | 2170 | 1 | t08U | RW | 0 | 1 | 0 | 0: Deactivated 1: Activated |
| Logical behavior of the area | 2170 | 2 | t08U | RW | 0 | 1 | 0 | 0: Normal - light switching 1: Inverted - dark switching |
| Start beam of the area | 2170 | 3 | t16U | RW | 1 | 0xFFFFE | 1 | 1 ... 1776 65534: First interrupted beam (FIB) 65533: First uninterrupted beam (FNIB) 65532: Last interrupted beam (LIB) 65531: Last uninterrupted beam (LNIB) |
| End beam of the area | 2170 | 4 | t16U | RW | 1 | 0xFFFFE | 1 | 1 ... 1776 65534: First interrupted beam (FIB) 65533: First uninterrupted beam (FNIB) 65532: Last interrupted beam (LIB) 65531: Last uninterrupted beam (LNIB) |
| Number of active beams for area ON | 2170 | 5 | t16U | RW | 0 | MAX_BEAM | 0 | 0 ... 1776 |
| Number of active beams for area OFF | 2170 | 6 | t16U | RW | 0 | MAX_BEAM | 0 | 0 ... 1776 |
| Specified middle of the area | 2170 | 7 | t16U | RW | 0 | MAX_BEAM | 0 | 0 ... 1776 |
| Specified width of the area | 2170 | 8 | t16U | RW | 0 | MAX_BEAM | 0 | 0 ... 1776 |
| Configuration of area 2 | 2171 | | | | | | | |
| Area | 2171 | 1 | t08U | RW | 0 | 1 | 0 | 0: Deactivated 1: Activated |
| Logical behavior of the area | 2171 | 2 | t08U | RW | 0 | 1 | 0 | 0: Normal - light switching 1: Inverted - dark switching |

| Parameter | Index (hex.) | Sub-index (hex) | Data type | Access | Min. value | Max. value | Default | Description |
|---|--------------|-----------------|-----------|--------|------------|------------|---------|--|
| Start beam of the area | 2171 | 3 | t16U | RW | 1 | 0xFFFE | 1 | 1 ... 1776 65534: First interrupted beam (FIB) 65533: First uninterrupted beam (FNIB) 65532: Last interrupted beam (LIB) 65531: Last uninterrupted beam (LNIB) |
| End beam of the area | 2171 | 4 | t16U | RW | 1 | 0xFFFE | 1 | 1 ... 1776 65534: First interrupted beam (FIB) 65533: First uninterrupted beam (FNIB) 65532: Last interrupted beam (LIB) 65531: Last uninterrupted beam (LNIB) |
| Number of active beams for area ON | 2171 | 5 | t16U | RW | 0 | MAX_BEAM | 0 | 0 ... 1776 |
| Number of active beams for area OFF | 2171 | 6 | t16U | RW | 0 | MAX_BEAM | 0 | 0 ... 1776 |
| Specified middle of the area | 2171 | 7 | t16U | RW | 0 | MAX_BEAM | 0 | 0 ... 1776 |
| Specified width of the area | 2171 | 8 | t16U | RW | 0 | MAX_BEAM | 0 | 0 ... 1776 |
| All other 30 areas are configured in the same way as described for 2170 and 2171: | | | | | | | | |
| Configuration of area 3 | 2172 | | | | | | | |
| Configuration of area 4 | 2173 | | | | | | | |
| Configuration of area 5 | 2174 | | | | | | | |
| Configuration of area 6 | 2175 | | | | | | | |
| Configuration of area 7 | 2176 | | | | | | | |
| Configuration of area 8 | 2177 | | | | | | | |
| Configuration of area 9 | 2178 | | | | | | | |
| Configuration of area 10 | 2179 | | | | | | | |
| Configuration of area 11 | 217A | | | | | | | |
| Configuration of area 12 | 217B | | | | | | | |
| Configuration of area 13 | 217C | | | | | | | |
| Configuration of area 14 | 217D | | | | | | | |
| Configuration of area 15 | 217E | | | | | | | |
| Configuration of area 16 | 217F | | | | | | | |
| Configuration of area 17 | 2180 | | | | | | | |
| Configuration of area 18 | 2181 | | | | | | | |
| Configuration of area 19 | 2182 | | | | | | | |
| Configuration of area 20 | 2183 | | | | | | | |
| Configuration of area 21 | 2184 | | | | | | | |
| Configuration of area 22 | 2185 | | | | | | | |
| Configuration of area 23 | 2186 | | | | | | | |
| Configuration of area 24 | 2187 | | | | | | | |
| Configuration of area 25 | 2188 | | | | | | | |

| Parameter | Index (hex.) | Sub-index (hex) | Data type | Access | Min. value | Max. value | Default | Description |
|--------------------------|--------------|-----------------|-----------|--------|------------|------------|---------|-------------|
| Configuration of area 26 | 2189 | | | | | | | |
| Configuration of area 27 | 218A | | | | | | | |
| Configuration of area 28 | 218B | | | | | | | |
| Configuration of area 29 | 218C | | | | | | | |
| Configuration of area 30 | 218D | | | | | | | |
| Configuration of area 31 | 218E | | | | | | | |
| Configuration of area 32 | 218F | | | | | | | |

Commands (module 9)

Procedure for "automatic" area splitting:

- ↳ Send the desired number of areas to the command argument (index 2200, Sub 2).
- ↳ Perform area splitting: set command argument (index 2200, sub 1) to value 8.

| Parameter | Index (hex.) | Sub-index (hex) | Data type | Access | Min. value | Max. value | Default | Description |
|--------------------|--------------|-----------------|-----------|--------|------------|------------|---------|--|
| Command Identifier | 2200 | 1 | t16U | WO | | | | <p>Command to be executed for write access</p> <p>0: Start measurement cycle 1: Stop measurement cycle</p> <p>Notice on measurement cycle: The commands "0: start measurement cycle" and "1: stop measurement cycle" start or stop measurement operation of the sensor. They are not normally needed, but are rather intended for switching off a specific light curtain during troubleshooting, etc.</p> <p>3: Teach 4: Reboot 5: Reset</p> <p>Notice on reset: Reset deletes the user settings. On the next PowerOn, the factory settings are applied. To reset to factory settings, a reboot must follow a reset.</p> <p>6: Save 7: Reserved 8: Splitting, division of the evaluation areas</p> |
| Command argument | 2200 | 2 | t16U | WO | | | | <p>Argument for command 8 (splitting): Into how many areas should the beams be split? Number of areas 1 ... N Enter value (max. 32): 1 N = 1: All beams of the light curtain form one area 2: N = 2: Beams are split into 2 equally large areas 3: N = 3: Beams are split into 3 equally large areas, etc. (bit: 0 ... 7)</p> <p>Notice on splitting: The result of the splitting function is written in the "configuration area ... " objects with indices 0x2170 ... 0x218F.</p> <hr/> <p>0: Area result active if a beam is interrupted (AND) 1: Area result active if all beams are interrupted (OR) (bit: 8)</p> |

Teach status (module 10)

| Parameter | Index (hex.) | Sub-index (hex) | Data type | Access | Min. value | Max. value | Default | Description |
|--------------|--------------|-----------------|-----------|--------|------------|------------|---------|---|
| Teach status | 2400 | 1 | t08S | RO | | MAX_T08U | | <p>Information about the last teach event: 0x00: Teach ok 0x01: Teach busy 0x80: Teach error (bit8 = error bit)</p> |

Check the alignment of the light curtains (module 11)



Information on the signal level of the first and last beam.

The value changes depending on the selected performance reserve.

| Parameter | Index (hex.) | Sub-index (hex) | Data type | Access | Min. value | Max. value | Default | Description |
|----------------------------|--------------|-----------------|-----------|--------|------------|------------|---------|----------------------------|
| Signal level of first beam | 2404 | 1 | t16U | RO | | | | Signal level on beam no. 1 |
| Signal level of last beam | 2404 | 2 | t16U | RO | | | | Signal level on beam no. n |

Process data (module 12)



Configuration of the process data:

- First interrupted/uninterrupted beam (FIB/FNIB),
- Last interrupted/uninterrupted beam (LIB/LNIB),
- Number of interrupted/uninterrupted beams (TIB/TNIB);
- Area Out 1-16 or 17-32; digital inputs/outputs

| Parameter | Index (hex.) | Sub-index (hex) | Data type | Access | Min. value | Max. value | Default | Description |
|--------------------------------------|--------------|-----------------|--------------|----------|------------|------------|---------|---|
| First interrupted beam (FIB) | 2405 | | t16U | RO | | | | First interrupted beam |
| First uninterrupted beam (FNIB) | 2406 | | t16U | RO | | | | First uninterrupted beam |
| Last interrupted beam (LIB) | 2407 | | t16U | RO | | | | Last interrupted beam |
| Last uninterrupted beam (LNIB) | 2408 | | t16U | RO | | | | Last uninterrupted beam |
| Number of interrupted beams (TIB) | 2409 | | t16U | RO | | | | Sum of interrupted beams |
| Number of uninterrupted beams (TNIB) | 240A | | t16U | RO | | | | Sum of uninterrupted beams |
| Area Out - LoWord | 240D | | t16U | RO | | | | Logical value of areas 1 ... 16 |
| Area Out - HiWord | 240E | | t16U | RO | | | | Logical value of areas 17 ... 32 |
| Status of the digital inputs/outputs | 240F | | t16U | RO | | | | Representation of the hardware switching outputs; these are mapped to the areas |
| CML status information | 2411 | | t16U | RO | | | | Bits 0 ... 11: measurement cycle number of a measurement; Bits 12 ... 13: reserved; Bit 14: 1 = event (is set if the state changes) Cause/reason for event can be seen in index 2162. Bit 15: 1 = valid measurement result exists |
| Beam stream | 2412 | 1 | t16U [111] | RO | | | | Reading out of the beam states of all existing light axes Read out beam 1 ... 16 An object contains 16 light axes One bit is transmitted for each interrupted or uninterrupted beam in inverted operation |
| | | 2 | t16U | RO | | | | Read out beam 17 ... 32 |
| | | 3 ... | t16U | RO .. | | | | Read out beam 33 ... 48 |
| | | 6F | t16U | RO | | | 0 | Read out beam 1761 ... 1776 Beam n to (n+15) |

Status (module 13)



Information on the status of the light curtain.

| Parameter | Index (hex.) | Sub-index | Data type | Access | Min. value | Max. value | Default | Description |
|----------------|--------------|-----------|-----------|--------|------------|------------|---------|---|
| Device status | 2162 | | t16S | RO | | | | 0: Normal function 1: Teaching error 2: Internal temperature/voltage monitoring 3: Invalid configuration 4: Hardware error 5: 24 V voltage error (supply voltage U _B) 6: Transmitter and receiver incompatible 7: No connection to transmitter |
| RX Error Field | 2600 | | t16U | RO | | | | For internal diagnosis only |
| TX Error Field | 2601 | | t16U | RO | | | | For internal diagnosis only |

12 Starting up the device - Profibus fieldbus interface

The configuration of a Profibus fieldbus interface involves the following steps on the receiver control panel and in the fieldbus-specific configuration software.



The configurations that are available in the GSD file via the fieldbus-specific configuration software can, in part, also be performed via the receiver control panel. Both configuration types are stored in non-volatile memory so that they are retained the next time the device is switched on.

It is always the last set configurations which are active. If the last changes to the configuration were made via the receiver control panel, any settings changed via, e.g., the control or PC are overwritten.

General prerequisites:

- The measuring light curtain has been mounted (see chapter 6 „Mounting and installation“) and connected (see chapter 7 „Electrical connection“) correctly.
- The basic configuration has been performed (see chapter 8 „Starting up the device - Basic configuration“).

12.1 Defining the Profibus basic configuration on the receiver control panel

The parameters for the Profibus interface are defined with the slave address and baud rate configurations. The structure of these configurations in the receiver control panel menu is as follows:

| Level 0 | Level 1 | Level 2 | Description | | | | | | | |
|----------------|--------------|---------------|--|---|----------------|-----------|-----------|-------------|-------------|-------------|
| Main Settings | Mode | | Measurement operation Alignment | | | | | | | |
| | Command | | Teach Reset Factory Settings | | | | | | | |
| | Filter Depth | | (enter value) | | | | | | | |
| | Profibus | Slave address | | (enter value) min = 1 max = 126 | | | | | | |
| | | Baud rate | | <table border="1"> <tr> <td>3 MBaud</td> <td>1.5 MBaud</td> <td>500 kBaud</td> <td>187.5 kBaud</td> </tr> <tr> <td>93.75 kBaud</td> <td>45.45 kBaud</td> <td>19.2 kBaud</td> <td>9.6 kBaud</td> </tr> </table> | 3 MBaud | 1.5 MBaud | 500 kBaud | 187.5 kBaud | 93.75 kBaud | 45.45 kBaud |
| 3 MBaud | 1.5 MBaud | 500 kBaud | 187.5 kBaud | | | | | | | |
| 93.75 kBaud | 45.45 kBaud | 19.2 kBaud | 9.6 kBaud | | | | | | | |

Prerequisites:

- The measuring light curtain must be correctly aligned (see chapter 8.1 „Aligning transmitter and receiver“).
- The measuring light curtain must be correctly taught (see chapter 8.2 „Teaching the environmental conditions“).

The following procedure describes the configurations for Profibus interfaces.

↩ Select **Main Settings > Profibus > Slave Address**.

↩ Select **Main Settings > Profibus > Baud Rate**.

The Profibus address and baud rate are configured.

Possible additional configuration steps are performed within the configuration software for the fieldbus-specific interface.

12.2 Configurations with the fieldbus-specific software

General prerequisites:

- The measuring light curtain has been mounted (see chapter 6 „Mounting and installation“) and connected (see chapter 7 „Electrical connection“) correctly.
- The fieldbus-specific configuration software has been installed on the PC.
- The basic configuration has been performed (see chapter 8 „Starting up the device - Basic configuration“).
- The Profibus basic configurations have been performed:
 - Profibus address selected
 - Profibus baud rate selected

Specific prerequisites:

- The Profibus-specific GSD file must be installed on the PC.



The Profibus Device Description (GSD) can be used both with connected light curtain for direct configuration as well as “off-line” without connected light curtain for creating device configurations.

The GSD file is supplied with the product. It can also be downloaded from the Internet at “www.leuze.com”.

NOTICE

Configuration dependent on the fieldbus-specific software!

- ↪ The sequence of the configurations is dependent on the fieldbus-specific software.
- ↪ First configure the GSD file while off-line.
- ↪ Once all parameters have been configured, transmit them to the CML.



Information on using the configuration parameters can be found in the general descriptions of the individual functions of the CML (see chapter 4 „Functions“).

- ↪ Open the interface software.
- ↪ Configure the following configuration parameters:
 - Operating mode (parallel-beam; diagonal-beam; crossed-beam)
 - Blanking areas
- ↪ Perform a teach.
- ↪ If necessary, configure additional parameter/process data (see chapter 12.3 „Parameter/process data for Profibus“).
- ↪ Save the configuration.

The Profibus-specific configurations have been performed, copied to the CML and the CML is ready for measurement operation.

12.3 Parameter/process data for Profibus

12.3.1 General information on Profibus

In addition to the basic configurations (see chapter 8 „Starting up the device - Basic configuration“), the functionality of the CML is defined via the GSD modules. The necessary modules are linked and appropriately configured for the given measurement application with a user-specific PLC configuration software program.

NOTICE

Extended configuration of the CML via Profibus if the CML is operated via Profibus!

↳ If the CML is operated on a Profibus control, the extended configuration may only be performed via the Profibus.

For operation of the CML on the Profibus, all configuration parameters are set to adjustment values ex works. If you do not change these configuration parameters, the CML operates with the adjustment values set ex works by Leuze electronic on delivery. For the adjustment values set ex works, please refer to the following module descriptions.

NOTICE

Working with the GSD file modules!

↳ At least one module must be configured with input data from the GSD file in the fieldbus-specific configuration software, e.g., module 1 “evaluation functions (16 bit)”.

↳ Some programmable logic controls make available a so-called “universal module”. This module is used for control purposes and must not be activated for the CML.

12.4 Parameter/process data for Profibus

The configuration parameters or process data for Profibus is defined via the following module descriptions.

Module overview

| Module no. | Module name | ID (HEX) | Parameter | Inputs | Outputs |
|------------|-------------------------------|----------|-----------|--------|---------|
| Module 0 | Sensor control module | 0xC0 | 1 | 0 | 2 |
| Module 1 | Evaluation functions (16 bit) | 0xF0 | 1 | 2 | 0 |
| Module 2 | BeamStream (16 bit) | 0xB0 | 1 | 2 | 0 |
| Module 3 | BeamStream (32 bit) | 0xB1 | 1 | 4 | 0 |
| Module 4 | BeamStream (64 bit) | 0xB2 | 1 | 8 | 0 |
| Module 5 | BeamStream (128 bit) | 0xB3 | 1 | 16 | 0 |
| Module 6 | BeamStream (256 bit) | 0xB4 | 1 | 32 | 0 |
| Module 7 | Read device parameters | 0xE0 | 1 | 0 | 0 |
| Module 8 | General settings | 0xD0 | 3 | 0 | 0 |
| Module 9 | Extended settings | 0xD1 | 4 | 0 | 0 |
| Module 10 | Configuration digital I/Os | 0xD2 | 15 | 0 | 0 |
| Module 11 | Teach settings | 0xD3 | 3 | 0 | 0 |
| Module 12 | Cascading configuration | 0xD4 | 7 | 0 | 0 |
| Module 13 | Blanking configuration | 0xD6 | 19 | 0 | 0 |
| Module 14 | Autosplitting configuration | 0xD7 | 1 | 0 | 0 |
| Module 15 | Area settings | 0xD8 | 13 | 0 | 0 |

Sensor control module (module 0)



The sensor control module allows the CML to control via the process data with byte 1 and byte 2. In both cases, the command is triggered in the device by incrementing the data value.

| Parameter | Rel. addr. | Data type | Value range | Default | Description |
|-----------------------|------------|-----------|------------------------------------|---------|-------------|
| Sensor control module | | | Trigger = byte 1 Teach = byte 2 | | |

Evaluation function (16 bit) (module 1)



Configuration of the process data module (16 bit):

- First interrupted/uninterrupted beam (FIB/FNIB),
- Last interrupted/uninterrupted beam (LIB/LNIB),
- Number of interrupted/uninterrupted beams (TIB/TNIB);
- Status area 1 ... 32

| Parameter | Rel. addr. | Data type | Value range | Default | Description |
|---------------------|------------|-------------------|-------------|---------|---|
| Evaluation function | 0 | Unsigned8 0-13 | 0 ... 13 | 0 | Process data module (16 bit) 0: No evaluation (NOP) 1: 1st interrupted beam 2: 1st uninterrupted beam 3: Last interrupted beam 4: Last uninterrupted beam 5: Number of interrupted beams 6: Number of uninterrupted beams 9: Status of areas 16 ... 1 10: Status of areas 32 ... 17 11: Status digital inputs/outputs 12: Status analog output 13: CML status information |

Beam stream (16 bit) (module 2)



Reading out of the beam states of all existing light axes. The object transmits the 16 light axes beginning with the configured optical cascade. One bit is transmitted for each interrupted or un-interrupted beam.

| Parameter | Rel. addr. | Data type | Value range | Default | Description |
|-------------------------------|------------|-----------|-------------|---------|---|
| Number of the optical cascade | 0 | Unsigned8 | 1 ... 111 | 0 | Number of the optical cascade beginning with which the beam-stream data is to be transmitted. |

Beam stream (32 bit) (module 3)



Reading out of the beam states of all existing light axes. The object transmits the 32 light axes beginning with the configured optical cascade. One bit is transmitted for each interrupted or un-interrupted beam.

| Parameter | Rel. addr. | Data type | Value range | Default | Description |
|-------------------------------|------------|-----------|-------------|---------|---|
| Number of the optical cascade | 0 | Unsigned8 | 1 ... 111 | 0 | Number of the optical cascade beginning with which the beam-stream data is to be transmitted. |

Beam stream (64 bit) (module 4)



Reading out of the beam states of all existing light axes. The object transmits the 64 light axes beginning with the configured optical cascade. One bit is transmitted for each interrupted or un-interrupted beam.

| Parameter | Rel. addr. | Data type | Value range | Default | Description |
|-------------------------------|------------|-----------|-------------|---------|---|
| Number of the optical cascade | 0 | Unsigned8 | 1 ... 111 | 0 | Number of the optical cascade beginning with which the beam-stream data is to be transmitted. |

Beam stream (128 bit) (module 5)



Reading out of the beam states of all existing light axes. The object transmits the 128 light axes beginning with the configured optical cascade. One bit is transmitted for each interrupted or un-interrupted beam.

| Parameter | Rel. addr. | Data type | Value range | Default | Description |
|-------------------------------|------------|-----------|-------------|---------|---|
| Number of the optical cascade | 0 | Unsigned8 | 1 ... 111 | 0 | Number of the optical cascade beginning with which the beam-stream data is to be transmitted. |

Beam stream (256 bit) (module 6)



Reading out of the beam states of all existing light axes. The object transmits the 256 light axes beginning with the configured optical cascade. One bit is transmitted for each interrupted or un-interrupted beam.

| Parameter | Rel. addr. | Data type | Value range | Default | Description |
|-------------------------------|------------|-----------|-------------|---------|---|
| Number of the optical cascade | 0 | Unsigned8 | 1 ... 111 | 0 | Number of the optical cascade beginning with which the beam-stream data is to be transmitted. |

Read device parameters (module 7)



With the “Read device parameters” module, various data (e.g., manufacturer, device type, serial number, etc.) can be read out for diagnostics or to check the configuration.

| Parameter | Rel. addr. | Data type | Value range | Default | Description |
|-----------|------------|------------------------|-------------|---------|---|
| Parameter | 0 | Unsigned8 0 ... 255 | 0 ... 161 | 0 | 0: ZERO 16: Manufacturer 17: Manufacturer text 18: Receiver product designation 19: Receiver part no. 20: Product description 21: Receiver serial number 22: Hardware version 23: Software version 24: Application-specific name 64: Transmitter product designation 65: Transmitter part no. 66: Transmitter serial number 67: Device description 68: Teach status 69: Status - alignment 70: General settings 71: Process data configuration 72: Cascading configuration 73: Extended settings 75: Blanking area configuration 76: Digital PNP/NPN 80: Digital IO 01 81: Digital IO 02 82: Digital IO 03 83: Digital IO 04 84: Digital Output 01 85: Digital Output 02 86: Digital Output 03 87: Digital Output 04 88: Analog output configuration 89: Analog function 100: Area 01 101: Area 02 102: Area 03 103: Area 04 104: Area 05 105: Area 06 106: Area 07 107: Area 08 108: Area 09 109: Area 10 110: Area 11 111: Area 12 112: Area 13 113: Area 14 114: Area 15 115: Area 16 116: Area 17 117: Area 18 118: Area 19 119: Area 20 120: Area 21 121: Area 22 122: Area 23 123: Area 24 124: Area 25 125: Area 26 126: Area 27 127: Area 28 128: Area 29 129: Area 30 130: Area 31 131: Area 32 150: 1st interrupted beam 151: 1st uninterrupted beam 152: Last interrupted beam 153: Last uninterrupted beam 154: Number of interrupted beams 155: Number of uninterrupted beams 158: Status of areas 16 ... 1 159: Status of areas 32 ... 17 160: Status of digital inputs/outputs 161: Status of analog output |

General settings (module 8)



Under general settings, the type of scanning (parallel-/diagonal-/crossed-beam), counting direction and minimum object for evaluation (smoothing) or minimum hole size (inverted smoothing) are set.

| Parameter | Rel. addr. | Data type | Value range | Default | Description |
|--------------------|------------|-----------------------------|-------------|---------|--|
| Operating mode | 0 | BitArea(4 ... 7) 0 ... 3 | 0 ... 2 | 0 | 0: Parallel-beam scanning 1: Diagonal-beam scanning 2: Crossed-beam scanning |
| Counting direction | 0 | Bit (0) 0 ... 1 | 0 ... 1 | 0 | 0: Normal (interface ->) 1: Inverted (-> interface) |
| Smoothing | 1 | Unsigned8 | 1 ... 255 | 1 | |
| Inverted smoothing | 2 | Unsigned8 | 1 ... 255 | 1 | |

Extended settings (module 9)



The filter depth indicates the necessary number of consistent beam states before the evaluation of the measurement values. All measurement values are accumulated and retained over the duration of the integration time.

| Parameter | Rel. addr. | Data type | Value range | Default | Description |
|-----------------------------------|------------|--------------------|-------------|---------|---|
| Autoteach on power-on | 0 | Bit (7) 0 ... 1 | 0 ... 1 | 0 | Automatic teach on power-on 0: Deactivated 1: Activated |
| Button lock on the display | 0 | Bit (0) 0 ... 1 | 0 ... 1 | 0 | 0: Deactivated 1: Activated |
| Filter depth [measurement cycles] | 1 | Unsigned8 | 1 ... 255 | 1 | |
| Integration/hold time [ms] | 2 | Unsigned8 | 1 ... 65535 | 0 | |

Configuration of digital I/Os (module 10)



Configuration of the inputs/outputs. The inputs/outputs can be set to positive switching (PNP) or to negative switching (NPN). The switching behavior applies the same for all inputs/outputs.

| Parameter | Rel. addr. | Data type | Value range | Default | Description |
|------------------------------------|------------|-----------------------------|------------------------------------|---------|---|
| Switching level of digital I/Os | 0 | Bit (7) 0 ... 1 | 0 ... 1 | 0 | 0: Transistor, NPN 1: Transistor, PNP |
| Pin 2 - Input/output selection | 0 | Bit (5) 0 ... 1 | 0 ... 1 | 0 | 0: Output 1: Input |
| Pin 2 - Switching behavior | 0 | Bit (4) 0 ... | 0 ... 1 | 0 | 0: Light switching: Rx light = '1' 1: Dark switching: Rx dark = '1' |
| Pin 2 - Input function | 0 | BitArea(2 ... 3) 0-2 | 0 ... 2 | | 0: Deactivated 1: Trigger input 2: Teach input |
| Pin 2 - Output function | 0 | BitArea(0 ... 1) 0 ... 3 | 0 ... 3 | | 0: Deactivated 1: Switching output (area 1 ... 32) 2: Warning output 3: Trigger output |
| Pin 2 - Time module operating mode | 1 | BitArea(4 ... 7) 0 ... 4 | 0 ... 4 | | 0: Deactivated 1: Start-up delay 2: Switch-off delay 3: Pulse stretching 4: Pulse suppression |
| Pin 2 - Delay time [ms] | 2 | Unsigned16 | 0 ... 65535 | | |
| Pin 2 - area mapping 32 ... 1 | 4 | Unsigned 32 | 0b00000000000000000000000000000000 | | |

| Parameter | Rel. addr. | Data type | Value range | Default | Description |
|------------------------------------|------------|-------------------------|------------------------------------|---------|---|
| Pin 5 - Input/output selection | 8 | Bit(5) 0 ... 1 | 0 ... 1 | | 0: Output 1: Input |
| Pin 5 - Switching behavior | 8 | Bit(4)0 ... 1 | 0 ... 1 | 0 | 0: Light switching: Rx light = '1' 1: Dark switching: Rx dark = '1' |
| Pin 5 - Input function | 8 | BitArea(2 ... 3)0 ... 2 | 0 ... 2 | | 0: Deactivated 1: Trigger input 2: Teach input |
| Pin 5 - Output function | 8 | BitArea(0 ... 1)0 ... 3 | 0 ... 3 | | 0: Deactivated 1: Switching output (area 1 ... 32) 2: Warning output 3: Trigger output |
| Pin 5 - Time module operating mode | 9 | BitArea(0 ... 3)0 ... 4 | 0 ... 4 | | 0: Deactivated 1: Start-up delay 2: Switch-off delay 3: Pulse stretching 4: Pulse suppression |
| Pin 5 - Delay time [ms] | 10 | Unsigned16 | 0-65535 | | |
| Pin 5 - area mapping 32 ... 1 | 12 | Unsigned32 | 0b00000000000000000000000000000000 | | |

Teach settings (module 11)



In most applications, it is recommended that the teach values be stored in non-volatile memory. Depending on the performance reserve selected for the teach, the sensitivity is higher or lower.

| Parameter | Rel. addr. | Data type | Value range | Default | Description |
|----------------------------------|------------|-------------------------|-------------|---------|---|
| Type of storage for teach values | 0 | BitArea(4 ... 7)0-1 | 0 ... 1 | 0 | 0: Non-volatile storage 1: Teach values stored only in RAM |
| Sensitivity adjustment | 0 | BitArea(0 ... 3)0 ... 3 | 0 ... 3 | 0 | 0: High performance reserve 1: Medium performance reserve 2: Low performance reserve 3: Detection of transparent media |
| Number of teach cycles | 1 | Unsigned8 | 1 ... 255 | 1 | |
| Switching threshold after teach | 2 | Unsigned8 | 10 ... 98 | 10 | |

Cascading configuration (module 12)



To prevent mutual interference, multiple CMLs can be operated with a time offset with respect to one another (cascade). Here, the master generates the cyclical trigger signal; the slaves start their measurement after delay times, which are to be set to different values.

| Parameter | Rel. addr. | Data type | Value range | Default | Description |
|------------------------------------|------------|---------------|---------------|---------|---|
| Cascading | 0 | Bit(7)0 ... 1 | 0 ... 1 | 0 | 0: Not active 1: Active |
| Function type | 0 | Bit(0)0 ..1 | 0 ... 1 | 0 | 0: slave (expects trigger signal) 1: master (sends trigger signal) |
| Delay time Trigger -> Scan [us] | 1 | Unsigned16 | 500 ... 65535 | 500 | |
| Pulse width of trigger signal [us] | 3 | Unsigned16 | 100 ... 65535 | 100 | |
| Master cycle time [ms] | 5 | Unsigned16 | 1 ... 6500 | 1 | |

Blanking configuration (module 13)



Up to 4 beam areas can be suppressed. Deactivated beams can be assigned the logical values 0, 1 or the value of the adjacent beam. With auto blanking, the selected area number (1 ... 4) is automatically suppressed during teaching.

| Parameter | Rel. addr. | Data type | Value range | Default | Description |
|---------------------------------|------------|------------------------------|-------------|---------|--|
| Number of auto-blanking areas | 0 | BitArea(4 ... 7) 0 ... 4 | 0 ... 4 | 0 | 0: 0 auto-blanking areas 1: 1 auto-blanking area 2: 2 auto-blanking areas 3: 3 auto-blanking areas 4: 4 auto-blanking areas |
| Auto blanking (during teaching) | 0 | Bit(0) 0 ... 1 | 0 ... 1 | 0 | 0: Not active 1: Active |
| Log. value for blanking area 1 | 1 | BitArea(4 ... 7) 0 ... 4 | 0 ... 4 | 0 | 0: No beams blanked 1: Blanked beams = log. 0 2: Blanked beams = log. 1 3: Value = lower-value neighbor 4: Value = higher-value neighbor |
| Start beam of blanking area 1 | 2 | Unsigned16 | 1 ... 1776 | 1 | |
| End beam of blanking area 1 | 4 | Unsigned16 | 1 ... 1776 | 1 | |
| Log. value for blanking area 2 | 6 | BitArea(0 ... 3) 0 ... 4. | 0 ... 4 | 0 | 0: No beams blanked 1: Blanked beams = log. 0 2: Blanked beams = log. 1 3: Value = lower-value neighbor 4: Value = higher-value neighbor |
| Start beam of blanking area 2 | 7 | Unsigned16 | 1 ... 1776 | 1 | |
| End beam of blanking area 2 | 9 | Unsigned16 | 1 ... 1776 | 1 | |
| Log. value for blanking area 3 | 11 | BitArea(4 ... 7) 0 ... 4 | 0 ... 4 | 0 | 0: No beams blanked 1: Blanked beams = log. 0 2: Blanked beams = log. 1 3: Value = lower-value neighbor 4: Value = higher-value neighbor |
| Start beam of blanking area 3 | 12 | Unsigned16 | 1 ... 1776 | 1 | |
| End beam of blanking area 3 | 14 | Unsigned16 | 1 ... 1776 | 1 | |
| Log. value for blanking area 4 | 16 | BitArea(0 ... 3) 0 ... 4 | 0 ... 4 | 0 | 0: No beams blanked 1: Blanked beams = log. 0 2: Blanked beams = log. 1 3: Value = lower-value neighbor 4: Value = higher-value neighbor |
| Start beam of blanking area 4 | 17 | Unsigned16 | 1 ... 1776 | 1 | |
| End beam of blanking area 4 | 19 | Unsigned16 | 1 ... 1776 | 1 | |

Autosplitting configuration (module 14)



Configuration of autosplitting (areas).

| Parameter | Rel. addr. | Data type | Value range | Default | Description |
|------------------------------|------------|------------------|-------------|---------|---|
| Logical behavior of the area | 0 | Bit(7)0 ... 1 | 0 ... 1 | 0 | 0: Logical OR linked 1: Logical AND linked |
| Number of areas | 0 | BitArea(0 ... 6) | 1 ... 111 | 1 | Number of areas for autosplitting |

Area settings (module 15)



Configuration of the respective area: definition of the status conditions so that the area takes on a logical 1 or 0. For diagonal- or crossed-beam mode, the numbers of the logical beams are to be entered.

| Parameter | Rel. addr. | Data type | Value range | Default | Description |
|-------------------------------|------------|------------------------------|--|---------|---|
| Area configuration | 0 | BitArea(0 ... 5) 1 ... 32 | 1 ... 32 | 1 | 1: Area 01 2: Area 02 3: Area 03 4: Area 04 5: Area 05 6: Area 06 7: Area 07 8: Area 08 9: Area 09 10: Area 10 11: Area 11 12: Area 12 13: Area 13 14: Area 14 15: Area 15 16: Area 16 17: Area 17 18: Area 18 19: Area 19 20: Area 20 21: Area 21 22: Area 22 23: Area 23 24: Area 24 25: Area 25 26: Area 26 27: Area 27 28: Area 28 29: Area 29 30: Area 30 31: Area 31 32: Area 32 |
| Area (active/not active) | 0 | Bit(7) 0 ... 1 | 0 ... 1 | 0 | 0: Deactivated 1: Activated |
| Logical behavior of the area | 0 | Bit(6) 0 ... 1 | 0 ... 1 | 0 | 0: active HIGH 1: active LOW |
| Start beam of the area | 1 | Unsigned16 | 1 ... 1776 65534 65533 65532 65531 | 1 | 65534: First interrupted beam (FIB) 65533: First uninterrupted beam (FNIB) 65532: Last interrupted beam (LIB) 65531: Last uninterrupted beam (LNIB) |
| End beam of the area | 3 | Unsigned16 | 1 ... 1776 65534 65533 65532 65531 | 1 | 65534: First interrupted beam (FIB) 65533: First uninterrupted beam (FNIB) 65532: Last interrupted beam (LIB) 65531: Last uninterrupted beam (LNIB) |
| Number of active beams -> ON | 5 | Unsigned16 | 0 ... 1776 | 0 | |
| Number of active beams -> OFF | 7 | Unsigned16 | 0 ... 1776 | 0 | |
| Specified middle of the area | 9 | Unsigned16 | 0 ... 1776 | 0 | |
| Specified width of the area | 11 | Unsigned16 | 0 ... 1776 | 0 | |

13 Example configurations

13.1 Example configurations for reading out 64 beams (beam stream)

The beam-stream evaluation function is used, e.g., for evaluating the size and position of objects on a transport system.

13.1.1 Configuration of beam-stream process data via IO-Link interface

↪ Map the beam states of the individual optical cascades in the CML to the process data as follows:

| | | |
|---|------------------------------|---|
| Evaluation function 01 (group 6) | Index 72, bit offset 120 = 1 | (The first optical cascade (beams 1 ... 16) is transmitted in process data module 01) |
| Evaluation function 02 (group 6) | Index 72, bit offset 112 = 2 | (The second optical cascade (beams 17 ... 32) is transmitted in process data module 02) |
| Evaluation function 03 (group 6) | Index 72, bit offset 104 = 3 | (The third optical cascade (beams 33 ... 48) is transmitted in process data module 03) |
| Evaluation function 04 (group 6) | Index 72, bit offset 96: = 4 | (The fourth optical cascade (beams 49 ... 64) is transmitted in process data module 04) |

13.1.2 Configuration of beam-stream process data via CANopen interface

↪ Map the TPDO1 as follows:

| | | |
|---------------|------------|---|
| MAPPINGENTRY1 | 0x24120110 | (Index 0x2412 sub-index 01 is mapped, Length of the mapped object: 16 bits) |
| MAPPINGENTRY2 | 0x24120210 | (Index 0x2412 sub-index 02 is mapped, Length of the mapped object: 16 bits) |
| MAPPINGENTRY3 | 0x24120310 | (Index 0x2412 sub-index 03 is mapped, Length of the mapped object: 16 bits) |
| MAPPINGENTRY4 | 0x24120410 | (Index 0x2412 sub-index 04 is mapped, Length of the mapped object: 16 bits) |

These 32 bits are to be read as follows:

| | | | |
|-------|-----------|--------|-----|
| 31 | 16 15 | 8 7 | 0 |
| Index | Sub-index | Length | |
| MSB | | | LSB |

This means that 4 x 16 bit objects can be mapped per PDO -> 64 beams.

13.1.3 Configuration of beam-stream process data via Profibus interface

↪ Map the beam states of the 64 beams starting with the first optical cascade in the CML to the beam stream (64 bits) as follows:

| | | |
|---------------------------------------|---|--|
| BeamStream (64 bit) (module 4) | Parameter "number of the optical cascade" = 1 | (The first optical cascade (beams 1 ... 64) is transmitted in the beam-stream module (64 bit)) |
|---------------------------------------|---|--|

13.2 Example configuration: mapping of beams 1 to 32 to output pin 2

13.2.1 Configuration of area/output mapping (general)

The following table shows an example configuration for an area mapping to an output. In this example, beams 1 to 32 are to be applied to output pin 2 on the X1 interface.

↪ Map beams 1 to 32 to area 01.

| |
|--|
| Description / variables |
| Display detailed area configuration Value: 0 = area 01 |
| Configuration of area 01 |
| Area Value: 1 = activated |

| | | | |
|--|----------------------------|------|---------------------------------------|
| Configuration of area 01 (group 16) | Index 100, bit offset 104: | = 1 | (area 01 activated) |
| | Index 100, bit offset 96: | = 0 | (light switching) |
| | Index 100, bit offset 80: | = 1 | (start beam of the area) |
| | Index 100, bit offset 64: | = 32 | (end beam of the area) |
| | Index 100, bit offset 48: | = 32 | (number of active beams for area ON) |
| | Index 100, bit offset 32: | = 31 | (number of active beams for area OFF) |
| Digital IO Pin 2 Settings (group 11/12) | Index 80, bit offset 24: | = 0 | (pin 2 as output) |
| | Index 80, bit offset 16: | = 1 | (switching behavior inverted) |
| | Index 80, bit offset 0: | = 1 | (switching output area 32 ... 1) |
| | Index 84, bit offset 0: | = 1 | (bit mapping of area 01 to pin 2) |

13.2.3 Configuration of area/output mapping via CANopen interface

↪ Map the beams to an output pin as follows:

| | | | |
|---|----------------|------|---------------------------------------|
| Configuration of area 01 (module 8) | 0x2170 sub 01: | = 1 | (area 01 activated) |
| | 0x2170 sub 02: | = 0 | (light switching) |
| | 0x2170 sub 03: | = 1 | (start beam of the area) |
| | 0x2170 sub 04: | = 32 | (end beam of the area) |
| | 0x2170 sub 05: | = 32 | (number of active beams for area ON) |
| | 0x2170 sub 06: | = 31 | (number of active beams for area OFF) |
| Switching level of the inputs/outputs (module 7) | 0x2151 sub 01: | = 0 | (pin 2 as output) |
| | 0x2151 sub 03: | = 1 | (switching behavior inverted) |
| | 0x2151 sub 04: | = 1 | (switching output area 32 ... 1) |
| | 0x2155 sub 03: | = 1 | (bit mapping of area 01 to pin 2) |

13.2.4 Configuration of area/output mapping via Profibus interface

↪ Map the beams to an output pin as follows:

| | | | |
|--|---|------|---------------------------------------|
| Area settings (module 15) | Parameter "Area configuration": | = 1 | (area 01 selected) |
| | Parameter "Area": | = 1 | (area 01 activated) |
| | Parameter "Logical behavior of the area": | = 0 | (active HIGH) |
| | Parameter "Start beam of the area": | = 1 | (start beam of the area) |
| | Parameter "End beam of the area": | = 32 | (end beam of the area) |
| | Parameter "Number of active beams -> ON": | = 32 | (number of active beams for area ON) |
| | Parameter "Number of active beams -> OFF": | = 31 | (number of active beams for area OFF) |
| Configuration of digital I/Os (module 10) | Parameter "Pin 2 - Input/output selection": | = 0 | (pin 2 as output) |
| | Parameter "Pin 2 - Switching behavior": | = 1 | (switching behavior inverted) |
| | Parameter "Pin 2 - Output function": | = 1 | (switching output area 1 ... 32) |
| | Parameter "Pin 2 - area mapping 32 ... 1": | = 1 | (bit mapping of area 01 to pin 2) |

13.3 Example configuration - hole recognition

The following table shows an example configuration for hole recognition for a web with signaling of a hole at output pin 2. Example for detection beginning with a free beam with fixed / dynamic web position.

↪ Map an area 01.

| Description / variables | | |
|--|------|---|
| Configuration of area 01 | | |
| Area Value: 1 = activated | 0x01 | This area is then mapped to output pin 2. |
| Logical behavior of the area Value: 1 = inverted - dark switching | 0x01 | Beams are darkened depending on the web width; the logical behavior is thus dark switching. |
| Start beam of the area Value: 5, if a fixed position value is specified Value: FIB, for dynamic web position | 5 | Evaluation of hole recognition begins with this beam (no. 5). If a hole is to be detected in a web with arbitrary position or width, the value FIB is to be set for the start beam. |
| End beam of the area Value: 25, if a fixed position value is specified Value: LIB, for dynamic web position | 25 | Evaluation of hole recognition ends with this beam (no. 25). If a hole is to be detected in a web with arbitrary position or width, the value LIB is to be set for the end beam. |
| Number of active beams for area ON Value: 21 | 21 | With this setting, the area (output) switches as soon as one or more beams are not interrupted. |
| Number of active beams for area OFF Value: 20 | 20 | |

↪ Map the area to the corresponding switching output.

| Description / variables | | |
|---|--|---|
| Configuration pin 2 | | |
| Area (area 1 ... 32) Value: 1 = switching output | 0x00000001 | |
| Switching behavior Value: 0 = normal - light switching | Switching behavior Value: 1 = inverted - dark switching | Configuration according to the necessary switching behavior of the output |
| Input/output selection Value: 0 = output | 0x00000000 | |

↪ Map the configured area 01 to pin 2.

| | |
|---|------------|
| Digital Output 2 Settings | |
| Area mapping 32 ... 1 (OR combination) | 0x00000001 |

13.3.1 Configuration of hole recognition via IO-Link interface

↪ For hole recognition for a web with signaling of a hole at the output, map to pin 2.

| | | |
|--|--------------------------------|---|
| Configuration of area 01 (group 16) | Index 100, bit offset 104: = 1 | (area 01 activated) |
| | Index 100, bit offset 96: = 1 | (dark switching) |
| | Index 100, bit offset 80: = 5 | (start beam of the area) dynamic: on 65534 (start beam = FIB) |
| | Index 100, bit offset 64: = 25 | (end beam of the area) dynamic: on 65532 (start beam = LIB) |
| | Index 100, bit offset 48: = 20 | (number of active beams for area ON) |
| | Index 100, bit offset 32: = 21 | (number of active beams for area OFF) |
| Digital IO Pin 2 Settings (group 11/12) | Index 80, bit offset 24: = 0 | (pin 2 as output) |
| | Index 80, bit offset 16: = 1 | (switching behavior inverted) |
| | Index 80, bit offset 0: = 1 | (switching output area 32 ... 1) |
| | Index 84, bit offset 0: = 1 | (bit mapping of area 01 to pin 2) |

13.3.2 Configuration of hole recognition via CANopen interface

↪ For hole recognition for a web with signaling of a hole at the output, map to pin 2.

| | | | |
|---|----------------|------|---|
| Configuration of area 01 (module 8) | 0x2170 sub 01: | = 1 | (area 01 activated) |
| | 0x2170 sub 02: | = 1 | (dark switching) |
| | 0x2170 sub 03: | = 5 | (start beam of the area) dynamic: on 65534 (start beam = FIB) |
| | 0x2170 sub 04: | = 25 | (end beam of the area) dynamic: on 65532 (start beam = LIB) |
| | 0x2170 sub 05: | = 20 | (number of active beams for area ON) |
| | 0x2170 sub 06: | = 21 | (number of active beams for area OFF) |
| Switching level of the inputs/outputs (module 7) | 0x2151 sub 01: | = 0 | (pin 2 as output) |
| | 0x2151 sub 03: | = 1 | (switching behavior inverted) |
| | 0x2151 sub 04: | = 1 | (switching output area 32 ... 1) |
| | 0x2155 sub 03: | = 1 | (bit mapping of area 01 to pin 2) |

13.3.3 Configuration of hole recognition via Profibus interface

↪ For hole recognition for a web with signaling of a hole at the output, map to pin 2.

| | | | |
|---|---|------|---|
| Area settings (module 15) | Parameter "Area configuration": | = 1 | (area 01 selected) |
| | Parameter "Area": | = 1 | (area 01 activated) |
| | Parameter "Logical behavior of the area": | = 1 | (active LOW) |
| | Parameter "Start beam of the area": | = 5 | (start beam of the area) dynamic: on 65534 (start beam = FIB) |
| | Parameter "End beam of the area": | = 25 | (end beam of the area) dynamic: on 65532 (start beam = LIB) |
| | Parameter "Number of active beams -> ON": | = 20 | (number of active beams for area ON) |
| | Parameter "Number of active beams -> OFF": | = 21 | (number of active beams for area OFF) |
| Configuration digital I/Os (module 10) | Parameter "Pin 2 - Input/output selection": | = 0 | (pin 2 as output) |
| | Parameter "Pin 2 - Switching behavior": | = 1 | (switching behavior inverted) |
| | Parameter "Pin 2 - Output function": | = 1 | (switching output area 1 ... 32) |
| | Parameter "Pin 2 - area mapping 32 ... 1": | = 1 | (bit mapping of area 01 to pin 2) |

13.4 Example configuration - activating and deactivating blanking areas

13.4.1 Configuration of blanking areas (general)

↪ Perform the following settings to activate or deactivate blanking areas.

Example: automatic blanking of 2 areas during teaching

| | | | |
|------------------------|--|-----|--|
| Blanking settings | Parameter "Number of auto blanking areas": | = 2 | (2 blanking areas permitted) |
| | Parameter "Auto blanking (during teaching)": | = 1 | (automatic blanking-area configuration active) |
| System commands | Parameter "Teach command": | = 1 | (execute teach command) |

Example: deactivating / resetting the blanking areas

| | | | |
|------------------------|--|-----|--|
| Blanking settings | Parameter "Number of auto blanking areas": | = 0 | (no blanking areas permitted) |
| | Parameter "Auto blanking (during teaching)": | = 1 | (automatic blanking-area configuration active) |
| System commands | Parameter "Teach command": | = 1 | (execute teach command) |

13.4.2 Configuration of blanking areas via IO-Link interface

↪ Map for blanking area activation and deactivation.

Example: automatic blanking of 2 areas during teaching

| | | | |
|--------------------------------|---------------------------|-------|--|
| Blanking settings (group 7) | Index 76, bit offset 200: | = 2 | (2 blanking areas permitted) |
| | Index 76, bit offset 192: | = 1 | (automatic blanking-area configuration active) |
| System commands (group 1) | Index 2 | = 162 | (perform teach) |

In the background, the values of objects INDEX 76 sub-index 3 ff. are calculated and stored in non-volatile memory. Upon successful teach completion, all other objects of index 76 are stored in non-volatile memory if index 79, sub-index 2 is set to value 0 = non-volatile storage of teach values.

Example: deactivating / resetting the blanking areas

| | | | |
|--------------------------------|---------------------------|-------|--|
| Blanking settings (group 7) | Index 76, bit offset 200: | = 0 | (no blanking areas permitted) |
| | Index 76, bit offset 192: | = 1 | (automatic blanking-area configuration active) |
| System commands (group 1) | Index 2: | = 162 | (perform teach) |

13.4.3 Configuration of blanking areas via CANopen interface

↳ Map for blanking area activation and deactivation:

Example: automatic blanking of 2 areas during teaching

| | | | |
|---------------------------------|----------------|-----|--|
| Blanking settings (module 6) | 0x2104 sub 01: | = 2 | (2 blanking areas permitted) |
| | 0x2104 sub 02: | = 1 | (automatic blanking-area configuration active) |
| Commands (module 9) | 0x2200 sub 01: | = 3 | (perform teach) |

In the background, the values of objects 0x2104 sub 04 and 0x2104 sub 05 as well as 0x2104 sub 07 and 0x2104 sub 08 are calculated and stored in non-volatile memory. Following a successful teach, all other 0x2104 objects are stored in non-volatile memory if 0x2103 sub 02 is set to value 0 = non-volatile storage of teach values.

Example: deactivating / resetting the blanking areas

| | | | |
|---------------------------------|----------------|-----|--|
| Blanking settings (module 6) | 0x2104 sub 01: | = 0 | (no blanking areas permitted) |
| | 0x2104 sub 02: | = 1 | (automatic blanking-area configuration active) |
| Commands (module 9) | 0x2200 sub 01: | = 3 | (perform teach) |

13.4.4 Configuration of blanking areas via Profibus interface

↳ Map for blanking area activation and deactivation:

Example: automatic blanking of 2 areas during teaching

| | | | |
|---------------------------------------|---|-----|--|
| Blanking configuration (module 13) | Parameter "Number of auto blanking areas" | = 2 | (2 blanking areas permitted) |
| | Parameter "Auto blanking (during teaching)" | = 1 | (automatic blanking-area configuration active) |
| Sensor control module (module 0) | Increment value of byte 2 | | (perform teach) |

In the background, the configuration for blanking areas 01 and 02 is calculated and stored in non-volatile memory. Upon successful teach completion, all other objects of the blanking configuration are stored in non-volatile memory if the "Type of storage for teach values" parameter is set to value 0 = non-volatile storage of teach values.

Example: deactivating / resetting the blanking areas

| | |
|------------------------------------|--|
| Blanking configuration (module 13) | Parameter "Number of auto blanking areas" = 0 (no blanking areas permitted) |
| | Parameter "Auto blanking (during teaching)" = 1 (automatic blanking-area configuration active) |
| Sensor control module (module 0) | Increment value of byte 2 (perform teach) |

13.5 Example configuration - configuration of a cascade arrangement

13.5.1 Configuration of a cascade arrangement (general)

The following figure shows an example for a timing sequence of a cascading arrangement with three light curtains.

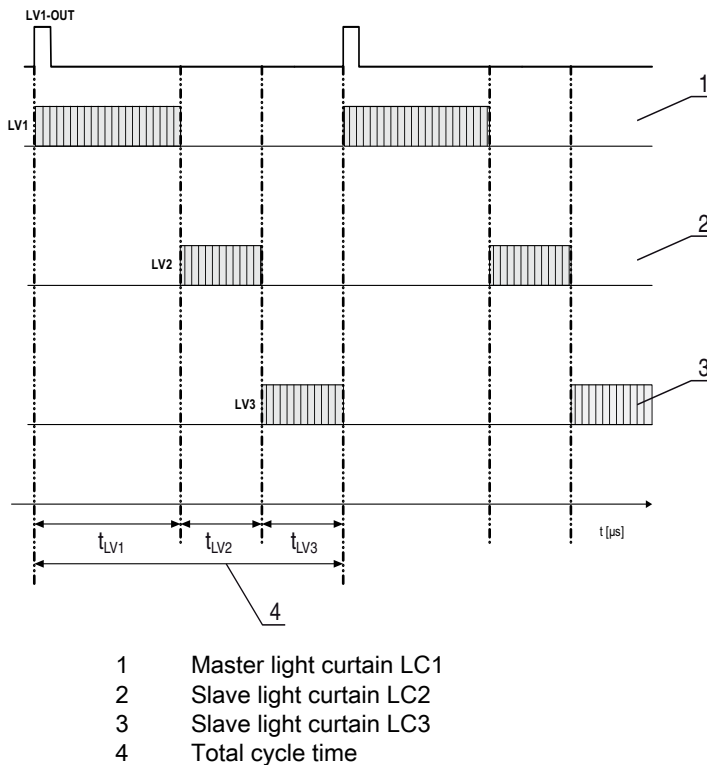

Figure 13.1: Example: cascading with three light curtains

Configuring light curtain 1:

Configure the trigger settings (triggered, master, total cycle time).

| | |
|--------------------------------|--|
| Cascading configuration | |
| Cascading | 1: Active Notice: With cascading operation, the master must also be set to 1 (active)! |
| Function type | 1: master (sends trigger signal) |
| Master cycle time | Total cycle time (= sum of cycle times of the light curtains LC1+LC2+LC3) duration of a TRIGGER cycle in ms |

Configure the digital IO (pin 5) settings.

| | |
|-------------------------------------|--------------------|
| Digital IO1 (Pin 5) Settings | |
| Pin 5 - Input/output selection | 1: Output |
| Pin 5 - Switching behavior | 0: Light switching |
| Pin 5 - Output function | 3: Trigger output |

Configuring light curtain 2:

↪ Configure the trigger settings (triggered, slave, delay time).

| | |
|---------------------------------|--|
| Cascading configuration | |
| Cascading | 1: Active Notice: With cascading operation, the master must also be set to 1 (active)! |
| Function type | 0: slave (expects trigger signal) |
| Delay time Trigger -> Scan [us] | Enter cycle time of light curtain 1 (LC1) |

↪ Configure the digital IO (pin 5) settings.

| | |
|-------------------------------------|--------------------|
| Digital IO1 (Pin 5) Settings | |
| Pin 5 - Input/output selection | 1: Input |
| Pin 5 - Switching behavior | 0: Light switching |
| Pin 5 - Output function | 1: Trigger input |

Configuring light curtain 3:

↪ Configure the trigger settings (triggered, slave, delay time).

| | |
|---------------------------------|--|
| Cascading configuration | |
| Cascading | 1: Active Notice: With cascading operation, the master must also be set to 1 (active)! |
| Function type | 0: slave (expects trigger signal) |
| Delay time Trigger -> Scan [us] | Enter cycle time of light curtain 1 and light curtain 2 (= sum of cycle times of light curtains LC1+LC2) |

↪ Configure the digital IO (pin 5) settings.

| | |
|-------------------------------------|--------------------|
| Digital IO1 (Pin 5) Settings | |
| Pin 5 - Input/output selection | 1: Input |
| Pin 5 - Switching behavior | 0: Light switching |
| Pin 5 - Output function | 1: Trigger input |

13.5.2 Configuration of a cascading arrangement via IO-Link interface

Configuring light curtain 1:

↪ Configure the trigger settings (triggered, master, total cycle time).

| | | |
|--|------------------------------|--|
| Cascading configuration (group 5) | Index 73, bit offset 56: = 1 | (cascading: active) Notice: With cascading operation, the master must also be set to 1 (active)! |
| | Index 73, bit offset 48: = 1 | (function type: master - sends trigger signal) |
| | Index 73, bit offset 32: | (master cycle time: total cycle time of all light curtains (LC1+LC2+LC3)) duration of a TRIGGER cycle in ms |

↪ Configure the digital IO (pin 5) settings.

| | | |
|--|------------------------------|---|
| Digital IO1 (Pin 5) Settings (group 11) | Index 81, bit offset 24: = 0 | (pin 5 - input/output selection: output) |
| | Index 81, bit offset 16: = 0 | (pin 5 - switching behavior: light switching) |
| | Index 81, bit offset 00 = 3 | (pin 5 - output function: trigger output) |

Configuring light curtain 2:

↪ Configure the trigger settings (triggered, slave, delay time).

| | | |
|--|------------------------------|--|
| Cascading configuration (group 5) | Index 73, bit offset 56: = 1 | (cascading: active) Notice: With cascading operation, the master must also be set to 1 (active)! |
| | Index 73, bit offset 48: = 0 | (function type: slave - expects trigger signal) |
| | Index 73, bit offset 00 | (delay time Trigger -> Scan [us]: enter cycle time of light curtain 1 (LC1)) |

↪ Configure the digital IO (pin 5) settings.

| | | |
|--|------------------------------|---|
| Digital IO1 (Pin 5) Settings (group 11) | Index 81, bit offset 24: = 1 | (pin 5 - input/output selection: input) |
| | Index 81, bit offset 16: = 0 | (pin 5 - switching behavior: light switching) |
| | Index 81, bit offset 08: = 1 | (pin 5 - output function: trigger input) |

Configuring light curtain 3:

↪ Configure the trigger settings (triggered, slave, delay time).

| | | |
|--|------------------------------|---|
| Cascading configuration (group 5) | Index 73, bit offset 56: = 1 | (cascading: active) Notice: With cascading operation, the master must also be set to 1 (active)! |
| | Index 73, bit offset 48: = 0 | (function type: slave - expects trigger signal) |
| | Index 73, bit offset 32: | (delay time Trigger -> Scan [us]: enter cycle time of light curtain 1 and light curtain 2 (= sum of the cycle times of light curtains LC1+LC2)) |

↪ Configure the digital IO (pin 5) settings.

| | | |
|--|------------------------------|---|
| Digital IO1 (Pin 5) Settings (group 11) | Index 81, bit offset 24: = 1 | (pin 5 - input/output selection: input) |
| | Index 81, bit offset 16: = 0 | (pin 5 - switching behavior: light switching) |
| | Index 81, bit offset 08: = 1 | (pin 5 - output function: trigger input) |

13.5.3 Configuration of a cascading arrangement via CANopen interface

Configuring light curtain 1:

↪ Configure the trigger settings (triggered, master, total cycle time).

| | | |
|--|-------------------|--|
| Cascading configuration (module 12) | 0x2102 Sub 01 = 1 | (cascading: active) Notice: With cascading operation, the master must also be set to 1 (active)! |
| | 0x2102 Sub 02 = 1 | (function type: master - sends trigger signal) |
| | 0x2102 Sub 05 | (master cycle time: total cycle time of all light curtains (LC1+LC2+LC3)) duration of a trigger cycle in ms |

↪ Configure the digital IO (pin 5) settings.

| | | |
|--|-------------------|---|
| Switching level of the inputs/outputs (module 10) | 0x2152 Sub 04 = 1 | (pin 5 - input/output selection: output) |
| | 0x2152 Sub 03 = 0 | (pin 5 - switching behavior: light switching) |
| | 0x2152 Sub 01 = 3 | (pin 5 - output function: trigger output) |

Configuring light curtain 2:

↪ Configure the trigger settings (triggered, slave, delay time).

| | | | |
|--|---------------|-----|--|
| Cascading configuration (module 12) | 0x2102 Sub 01 | = 1 | (cascading: active) Notice: With cascading operation, the master must also be set to 1 (active)! |
| | 0x2102 Sub 02 | = 0 | (function type: slave - expects trigger signal) |
| | 0x2102 Sub 03 | | (delay time Trigger -> Scan [us]: enter cycle time of light curtain 1 (LC1)) |

↪ Configure the digital IO (pin 5) settings.

| | | | |
|--|---------------|-----|---|
| Switching level of the inputs/outputs (module 10) | 0x2152 Sub 04 | = 1 | (pin 5 - input/output selection: input) |
| | 0x2152 Sub 03 | = 0 | (pin 5 - switching behavior: light switching) |
| | 0x2152 Sub 02 | = 1 | (pin 5 - input function: trigger input) |

Configuring light curtain 3:

↪ Configure the trigger settings (triggered, slave, delay time).

| | | | |
|--|---------------|-----|---|
| Cascading configuration (module 12) | 0x2102 Sub 01 | = 1 | (cascading: active) Notice: With cascading operation, the master must also be set to 1 (active)! |
| | 0x2102 Sub 02 | = 0 | (function type: slave - expects trigger signal) |
| | 0x2102 Sub 03 | | (delay time Trigger -> Scan [us]: enter cycle time of light curtain 1 and light curtain 2 (= sum of the cycle times of light curtains LC1+LC2)) |

↪ Configure the digital IO (pin 5) settings.

| | | | |
|--|---------------|-----|--|
| Switching level of the inputs/outputs (module 10) | 0x2152 Sub 04 | = 1 | (pin 5 - input/output selection = input) |
| | 0x2152 Sub 03 | = 0 | (pin 5 - switching behavior = light switching) |
| | 0x2152 Sub 02 | = 1 | (pin 5 - input function = trigger input) |

13.5.4 Configuration of a cascading arrangement via Profibus interface

Configuring light curtain 1:

↪ Configure the trigger settings (triggered, master, total cycle time).

| | | | |
|--|------------------------------------|-----|---|
| Cascading configuration (module 12) | Parameter "Cascading": | = 1 | (active) Notice: With cascading operation, the master must also be set to 1 (active)! |
| | Parameter "Function type" | = 1 | (master - sends trigger signal) |
| | Parameter "Master cycle time [ms]" | | (total cycle time of all light curtains (LC1+LC2+LC3)) duration of a TRIGGER cycle in ms |

↪ Configure the digital IO (pin 5) settings.

| | | | |
|---|--|-----|-------------------|
| Digital IO1 (Pin 5) Settings (module 10) | Parameter "Pin 5 - Input/output selection" | = 0 | (output) |
| | Parameter "Pin 5 - Switching behavior" | = 0 | (light switching) |
| | Parameter "Pin 5 - Output function" | = 3 | (trigger output) |

Configuring light curtain 2:

↪ Configure the trigger settings (triggered, slave, delay time).

| | |
|--|---|
| Cascading configuration (module 12) | Parameter "Cascading" = 1 (active) Notice: With cascading operation, the master must also be set to 1 (active)! |
| | Parameter "Function type" = 0 (slave - expects trigger signal) |
| | Parameter "Delay time Trigger -> Scan [us]" (enter cycle time of light curtain 1 (LC1)) |

↪ Configure the digital IO (pin 5) settings.

| | |
|---|--|
| Digital IO1 (Pin 5) Settings (module 10) | Parameter "Pin 5 - Input/output selection" = 1 (input) |
| | Parameter "Pin 5 - Switching behavior" = 0 (light switching) |
| | Parameter "Pin 5 - Input function" = 1 (trigger input) |

Configuring light curtain 3:

↪ Configure the trigger settings (triggered, slave, delay time).

| | |
|--|--|
| Cascading configuration (module 12) | Parameter "Cascading" = 1 (active) Notice: With cascading operation, the master must also be set to 1 (active)! |
| | Parameter "Function type" = 0 (slave - expects trigger signal) |
| | Parameter "Delay time Trigger -> Scan [us]" (enter cycle time of light curtain 1 and light curtain 2 (= sum of cycle times of light curtains LC1+LC2)) |

↪ Configure the digital IO (pin 5) settings.

| | |
|---|--|
| Digital IO1 (Pin 5) Settings (module 10) | Parameter "Pin 5 - Input/output selection" = 1 (input) |
| | Parameter "Pin 5 - Switching behavior" = 0 (light switching) |
| | Parameter "Pin 5 - Output function" = 1 (trigger input) |

14 Connection to a PC

14.1 Connection configuration

Independent of the selected process interface, each CML measuring light curtain can be operated and adjusted using the configuration software from Leuze electronic on a PC.

- ↪ Connect the USB master to the plug-in power supply unit or the mains supply.
- ↪ Connect the IO-Link USB master to the CML receiver on the X1 interface.



Included in the delivery contents of USB master is a USB connection cable for connecting the PC to the USB master as well as a plug-in power supply unit and a short description.

The USB master is equipped with an M12 connector (4-pin).

- ↪ Connect the PC to the IO-Link USB master ((see table 19.11), accessories).

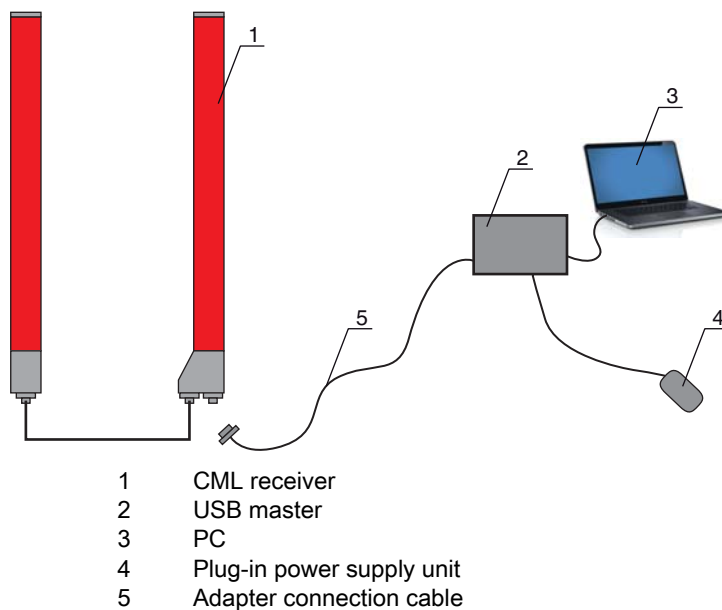

Figure 14.1: PC connection of the CML via the USB master

14.2 Installation requirements on the PC

IO-Link device configuration software

In terms of hardware, the following system recommendations are given for the IO-Link-Master V2.0:

- Processor with clock speed > 1 GHz
- At least 1 GB of free main memory (RAM)
- At least 20MB of free disk space if Microsoft .NET Framework 2.0 and Adobe Acrobat Reader are already installed
- At least 150MB free disk space if Microsoft .NET Framework 2.0 and Adobe Acrobat Reader are not already installed
- Microsoft XP with SP3 as operating system and Microsoft .NET Framework 2.0 or higher
- Free USB 1.1 or USB 2.0 interface



The IO-Link Device Tool software **was developed exclusively for use with the Microsoft Windows XP operating system**. It should, however, also run with Windows 2000.

As our products are continuously adapted to current market demands, please confer with your contact person to receive updates or have a look at our home page.

For further information, please refer to the technical documentation for the IO-Link device configuration software.

15 Troubleshooting

15.1 What to do in case of failure?

After switching on the measuring light curtain, display elements (see chapter 3.4 „Display elements“) assist in checking the proper function and troubleshooting.

In case of failure, you can determine the fault from the LED displays. With the error message you can determine the cause of the fault and initiate measures to rectifying it.

| |
|--|
| NOTICE |
| If the light curtain responds with an error display, you will often be able to eliminate the cause yourself! |
| ↪ Switch off the system and leave it switched off. |
| ↪ Analyze and eliminate the cause of the fault using the following table. |
| ↪ If you are unable to rectify the fault, contact the Leuze electronic branch responsible for you or call the Leuze electronic customer service (see chapter 17 „Service and support“, Service and support). |

15.2 Operating displays of the LEDs

Table 15.1: Receiver LED displays - state and causes

| Green LED | Yellow LED | State | Cause |
|----------------------------------|---------------------|-----------------------------|---|
| ON (continuous light) | - | Sensor ready | |
| OFF | OFF | Sensor not ready | Interruption of the operating voltage; Light curtain in start-up phase |
| OFF | Flashing (15 Hz) | Missing performance reserve | Soiling of lens covers; Misalignment of transmitter or receiver; Operating range exceeded |
| Flashing synchronously (3 Hz) | | Teach running | |
| Flashing synchronously (9 Hz) | | Teach error | Soiling of lens covers; Operating range exceeded |
| Flashing alternately (9 Hz) | | System error | No connection between transmitter and receiver; Operating voltage too low; Inconsistent configuration |

Table 15.2: LED displays - causes and measures

| Error | Cause | Measure |
|--|---|--|
| Teach error | Soiling of the lens covers; Poor alignment of transmitter and receiver | Clean the lens cover on the receiver and on the transmitter; Check alignment |
| Performance reserve too low | Poor alignment of transmitter and receiver; Soiling of the lens covers | Adjust alignment; Test with shorter distance between transmitter and receiver; Clean the lens cover on the receiver and on the transmitter |
| Alignment signal too low | Poor alignment of transmitter and receiver; Soiling of the lens covers | Adjust alignment; Test with shorter distance between transmitter and receiver; Clean the lens cover on the receiver and on the transmitter |
| Outputs are not active or change their state without a contour change in the measurement field | Configuration data is read or written | End configuration communication |



During teaching, the system checks whether the signals of all beams are within a certain corridor. If there are considerable deviations in the signal strength, this results in a teaching error and is indicated on the LEDs. The cause may be partial soiling of the lens cover.

Measure: clean the lens covers on the transmitter and receiver!

16 Care, maintenance and disposal

16.1 Cleaning

In the event of dust build-up on the sensor:

- ↳ Clean the sensor with a soft cloth; use a cleaning agent (commercially available glass cleaner) if necessary.

| |
|---|
| NOTICE |
| Do not use aggressive cleaning agents! |
| ↳ Do not use aggressive cleaning agents such as thinner or acetone for cleaning the measuring light curtains. |
| Use of improper cleaning agents can damage the lens cover. |

16.2 Servicing

The measuring light curtain does not usually require any maintenance by the operator.

Repairs to the device must only be carried out by the manufacturer.

- ↳ For repairs, contact your responsible Leuze electronic subsidiary or Leuze electronic customer service (see chapter 17 „Service and support“).

16.2.1 Firmware update

A firmware update can only be performed by Leuze electronic Service on-site or at the company headquarters.

- ↳ For firmware updates, contact your responsible Leuze electronic subsidiary or Leuze electronic customer service (see chapter 17 „Service and support“).

16.3 Disposing

For disposal observe the applicable national regulations regarding electronic components.

17 Service and support

Telephone number for 24-hour standby service:

+49 (0) 702 573-0

Service hotline:

+49 (0) 8141 5350-111

Monday to Thursday, 8.00 a.m. to 5.00 p.m. (UTC+1)

Friday, 8.00 a.m. to 4.00 p.m. (UTC+1)

E-mail:

service.detect@leuze.de

Return address for repairs:

Service Center

Leuze electronic GmbH + Co. KG

In der Braike 1

D-73277 Owen / Germany

18 Specifications

18.1 General specifications

Table 18.1: Optical data

| | |
|--------------|-------------------------|
| Light source | LED (modulated light) |
| Wavelength | 940 nm (infrared light) |

Table 18.2: Measurement field data: Operating range limit and measurement field length of the CML 730i

| Beam spacing [mm] | Typ. operating range limit ¹⁾ [m] | | Measurement field length ²⁾ [mm] | |
|-------------------|--|------|---|------|
| | min. | max. | min. | max. |
| 5 | 0.1 | 6.0 | 160 | 2960 |
| 10 | 0.2 | 12.0 | 160 | 2880 |
| 20 | 0.2 | 12.0 | 150 | 2870 |
| 40 | 0.2 | 12.0 | 290 | 2850 |

1) Typ. operating range limit: min./max. attainable range without performance reserve for parallel-beam scanning.

2) Measurement field lengths and beam spacings specified in fixed rasters, see ordering table.

Table 18.3: CML 730i Operating ranges

| Beam spacing [mm] | Operating range [m] Parallel-beam | | Operating range [m] Diagonal-beam | | Operating range [m] Crossed-beam | |
|-------------------|--------------------------------------|------|--------------------------------------|------|-------------------------------------|------|
| | min. | max. | min. | max. | min. | max. |
| 5 | 0.1 | 4.0 | 0.2 | 3.0 | 0.2 | 2.5 |
| 10 | 0.3 | 8.0 | 0.3 | 6.1 | 0.3 | 5.0 |
| 20 | 0.3 | 8.0 | 0.3 | 6.1 | 0.3 | 5.0 |
| 40 | 0.3 | 8.0 | 0.3 | 6.1 | 0.6 | 5.0 |

NOTICE

Reduction in operating range if sensitivity is set "for the detection of transparent media"!

↳ If the sensitivity is set for the detection of transparent media, the operating range is reduced to 0.3 ... 3.5 m (with beam spacing 10 mm, parallel-beam operation)

Table 18.4: Profile and measurement field length

| Measurement field length B [mm] at beam spacing A 5 [mm] | Measurement field length B [mm] at beam spacing A 10 [mm] | Measurement field length B [mm] at beam spacing A 20 [mm] | Measurement field length B [mm] at beam spacing A 40 [mm] | Profile length L [mm] |
|--|---|---|---|-----------------------|
| 160 | 160 | 150 | - | 162 |
| 240 | - | - | - | 242 |
| 320 | 320 | 310 | 290 | 322 |

| Measurement field length B [mm] at beam spacing A 5 [mm] | Measurement field length B [mm] at beam spacing A 10 [mm] | Measurement field length B [mm] at beam spacing A 20 [mm] | Measurement field length B [mm] at beam spacing A 40 [mm] | Profile length L [mm] |
|---|--|--|--|-----------------------|
| 400 | - | - | - | 402 |
| 480 | 480 | 470 | - | 482 |
| 560 | - | - | - | 562 |
| 640 | 640 | 630 | 610 | 642 |
| 720 | - | - | - | 722 |
| 800 | 800 | - | - | 802 |
| 880 | - | - | - | 882 |
| 960 | 960 | 950 | 930 | 962 |
| 1040 | - | - | - | 1042 |
| 1120 | 1120 | 1110 | - | 1122 |
| 1200 | - | - | - | 1202 |
| 1280 | 1280 | 1270 | 1250 | 1282 |
| 1360 | - | - | - | 1362 |
| 1440 | 1440 | 1430 | - | 1442 |
| 1520 | - | - | - | 1522 |
| 1600 | 1600 | 1590 | 1570 | 1602 |
| 1680 | - | - | - | 1682 |
| 1760 | 1760 | 1750 | - | 1762 |
| 1840 | - | - | - | 1842 |
| 1920 | 1920 | 1910 | 1890 | 1922 |
| 2000 | - | - | - | 2002 |
| 2080 | 2080 | 2070 | - | 2082 |
| 2160 | - | - | - | 2162 |
| 2240 | 2240 | 2230 | 2210 | 2242 |
| 2320 | - | - | - | 2322 |
| 2400 | 2400 | 2390 | - | 2402 |
| 2480 | - | - | - | 2482 |
| 2560 | 2560 | 2550 | 2530 | 2562 |
| 2640 | - | - | - | 2642 |
| 2720 | 2720 | 2710 | - | 2722 |

| Measurement field length B [mm] at beam spacing A 5 [mm] | Measurement field length B [mm] at beam spacing A 10 [mm] | Measurement field length B [mm] at beam spacing A 20 [mm] | Measurement field length B [mm] at beam spacing A 40 [mm] | Profile length L [mm] |
|---|--|--|--|-----------------------|
| 2800 | - | - | - | 2802 |
| 2880 | 2880 | 2870 | 2850 | 2882 |
| 2960 | - | - | - | 2962 |

Table 18.5: Data on the time behavior of the CML 730i

| | |
|--|---------------|
| Response time per beam ¹⁾ | 10 μ s |
| Readiness delay | \leq 400 ms |
| 1) cycle time = number of beams x 0.01 ms + 0.15 ms. The minimum cycle time is 1 ms. | |

Table 18.6: Electrical data

| | |
|-------------------------|--|
| Operating voltage U_B | 18 ... 30 VDC (incl. residual ripple) |
| Residual ripple | \leq 15 % within the limits of U_B |
| Open-circuit current | (see table 18.8) |

Table 18.7: Open-circuit current

| Measurement field length [mm] | Current consumption [mA] (without load at switching output) | | |
|-------------------------------|---|-----------------|-----------------|
| | at U_B 24 VDC | at U_B 18 VDC | at U_B 30 VDC |
| 160 | 135 | 165 | 125 |
| 320 | 165 | 200 | 145 |
| 640 | 215 | 275 | 190 |
| 960 | 270 | 345 | 235 |
| 1440 | 350 | 455 | 300 |
| 1920 | 435 | 650 | 365 |
| 2880 | 600 | 780 | 500 |

Table 18.8: Interface data

| | |
|----------------------------------|---|
| inputs/outputs | 2/4 pins can be configured as input or output |
| Switching output current | max. 100mA |
| Signal voltage active/not active | \geq 8 V / \leq 2 V |
| Activation delay | \leq 1 ms |

| | |
|--------------------|--|
| Input resistance | approx. 6 k Ω |
| Digital interfaces | IO-Link (230.4 kbit/s; 38.4 kbit/s) CANopen (max. 1 Mbit/s) Profibus (max. 3 Mbit/s) |
| Analog interfaces | 0 ... 10(11) V and 0(4) ... 20(24) mA |

Table 18.9: Mechanical data

| | |
|-----------------------|-----------------------------------|
| Housing | continuous-cast aluminum |
| Optics cover | PMMA plastic |
| Connection technology | M12 connectors (8-pin / 5-pin) |

Table 18.10: Environmental data

| | |
|-------------------------------|---|
| Temperature range (operation) | -20 °C ... +60 °C |
| Ambient temperature (storage) | -40 °C ... +70 °C |
| Protective circuit | Transient protection; Polarity reversal protection; Short circuit protection for all outputs (provide external protective circuit for inductive load for this purpose!) |

Table 18.11: Certifications

| | |
|-------------------|--|
| Protection class | IP 65 |
| Safety class | III |
| Certifications | Light source: exempt group (in acc. with EN 62471) |
| Standards applied | IEC 60947-5-2 |

18.2 Timing

In principle, the individual beams are always processed sequentially for measuring light curtains. The internal controller starts transmitter 1 and then activates only the corresponding receiver 1 to measure the received light power. If the measured value exceeds the switch-on threshold, this first beam is evaluated as an active beam.

The time between activation of the transmitter and evaluation in the receiver is referred to as the response time per beam. In the CML 730i, this is = 10 μs. The evaluation of all beams and transfer to the interface takes place at a defined rate.

The total cycle time is thus calculated as follows:

Cycle time = number of beams x response time per beam + constant

Example: cycle time = 192 beams x 0.01 ms + 0.15 ms = 2.17 ms



The minimum cycle time is 1 ms, i.e., the cycle time is never less than 1 ms, even with very short light curtains with a small number of beams.

Table 18.12: Profile and measurement field lengths, cycle times for CML 730i

| Measurement field length B [mm] | | Measurement field length B [mm] | | Measurement field length B [mm] | | Measurement field length B [mm] | | Profile length L [mm] |
|---------------------------------|-----------------|---------------------------------|-----------------|---------------------------------|-----------------|---------------------------------|-----------------|-----------------------|
| at beam spacing A 5 [mm] | Cycle time [ms] | at beam spacing A 10 [mm] | Cycle time [ms] | at beam spacing A 20 [mm] | Cycle time [ms] | at beam spacing A 40 [mm] | Cycle time [ms] | |
| 160 | 1.00 | 160 | 1.00 | 150 | 1.00 | - | - | 162 |
| 240 | 1.00 | - | - | - | - | - | - | 242 |
| 320 | 1.00 | 320 | 1.00 | 310 | 1.00 | 290 | 1.00 | 322 |
| 400 | 1.00 | - | - | - | - | - | - | 402 |
| 480 | 1.11 | 480 | 1.00 | 470 | 1.00 | - | - | 482 |
| 560 | 1.31 | - | - | - | - | - | - | 562 |
| 640 | 1.43 | 640 | 1.00 | 630 | 1.00 | 610 | 1.00 | 642 |
| 720 | 1.63 | - | - | - | - | - | - | 722 |
| 800 | 1.75 | 800 | 1.00 | - | - | - | - | 802 |
| 880 | 1.91 | - | - | - | - | - | - | 882 |
| 960 | 2.07 | 960 | 1.11 | 950 | 1.00 | 930 | 1.00 | 962 |
| 1040 | 2.23 | - | - | - | - | - | - | 1042 |
| 1120 | 2.35 | 1120 | 1.27 | 1110 | 1.00 | - | - | 1122 |
| 1200 | 2.55 | - | - | - | - | - | - | 1202 |
| 1280 | 2.71 | 1280 | 1.43 | 1270 | 1.00 | 1250 | 1.00 | 1282 |
| 1360 | 3.87 | - | - | - | - | - | - | 1362 |
| 1440 | 3.03 | 1440 | 1.59 | 1430 | 1.00 | - | - | 1442 |
| 1520 | 3.19 | - | - | - | - | - | - | 1522 |
| 1600 | 3.35 | 1600 | 1.75 | 1590 | 1.00 | 1570 | 1.00 | 1602 |
| 1680 | 3.51 | - | - | - | - | - | - | 1682 |
| 1760 | 3.57 | 1760 | 1.91 | 1750 | 1.03 | - | - | 1762 |
| 1840 | 4.83 | - | - | - | - | - | - | 1842 |
| 1920 | 4.99 | 1920 | 2.07 | 1910 | 1.11 | 1890 | 1.00 | 1922 |
| 2000 | 4.15 | - | - | - | - | - | - | 2002 |
| 2080 | 4.31 | 2080 | 2.23 | 2070 | 1.19 | - | - | 2082 |
| 2160 | 4.47 | - | - | - | - | - | - | 2162 |
| 2240 | 4.63 | 2240 | 2.39 | 2230 | 1.27 | 2210 | 1.00 | 2242 |
| 2320 | 4.79 | - | - | - | - | - | - | 2322 |
| 2400 | 4.95 | 2400 | 2.55 | 2390 | 1.35 | - | - | 2402 |
| 2480 | 5.21 | - | - | - | - | - | - | 2482 |
| 2560 | 5.37 | 2560 | 2.71 | 2550 | 1.43 | 2530 | 1.00 | 2562 |
| 2640 | 5.43 | - | - | - | - | - | - | 2642 |
| 2720 | 5.59 | 2720 | 2.87 | 2710 | 1.51 | - | - | 2722 |
| 2800 | 5.75 | - | - | - | - | - | - | 2802 |
| 2880 | 5.91 | 2880 | 3.13 | 2870 | 1.59 | 2850 | 1.00 | 2882 |
| 2960 | 6.07 | - | - | - | - | - | - | 2962 |

18.2.1 Limits for detecting objects

The detection of objects and the evaluation of the data depend on the following factors:

- Minimum object diameter or minimum object size for stationary objects
- Boundary conditions for pure detection of moving objects
- Transmission rate of the data bytes
- Cycle time of the PLC

Minimum object diameter for stationary objects

The minimum object diameter of a stationary object is determined by the beam spacing and optic diameter.

Minimum object size for parallel-beam operation:

Because objects must also be reliably detected in the transition area between two beams, the following relations apply.

| Beam spacing | Minimum object size |
|-----------------------|--|
| 5 mm | Beam spacing + 5 mm = 10 mm |
| 10 mm / 20 mm / 40 mm | Beam spacing + 10 mm = 20 mm / 30 mm / 50 mm |

| |
|--|
| NOTICE |
| Minimum object size for crossed-beam operation! |
| ↳ For crossed-beam operation, these values are reduced to 1/2 x beam spacing in the middle area. |

Boundary conditions for pure detection of moving objects

For a moving object, the cycle time of the light curtain must be shorter than the period of time that the object to be detected is located in the beam plane.

For an object that moves vertically to the beam plane, the following apply:

$$v_{max} = (L - 10mm) / (t_z)$$

- v_{max} [m/s] = Maximum object speed
- L [m/s] = Length of the object in the direction of movement
- t_z [s] = Cycle time of the light curtain

or

$$L_{min} = v \cdot t_z + 10mm$$

- L_{min} [m] = Length of the object in the direction of movement (minimum length)
- v [m/s] = Speed of the object
- t_z [s] = Cycle time of the light curtain

| |
|--|
| NOTICE |
| Minimum size of the gap between two successive objects |
| ↳ The gap between two successive objects must be greater than the minimum object length. |

18.3 Dimensioned drawings

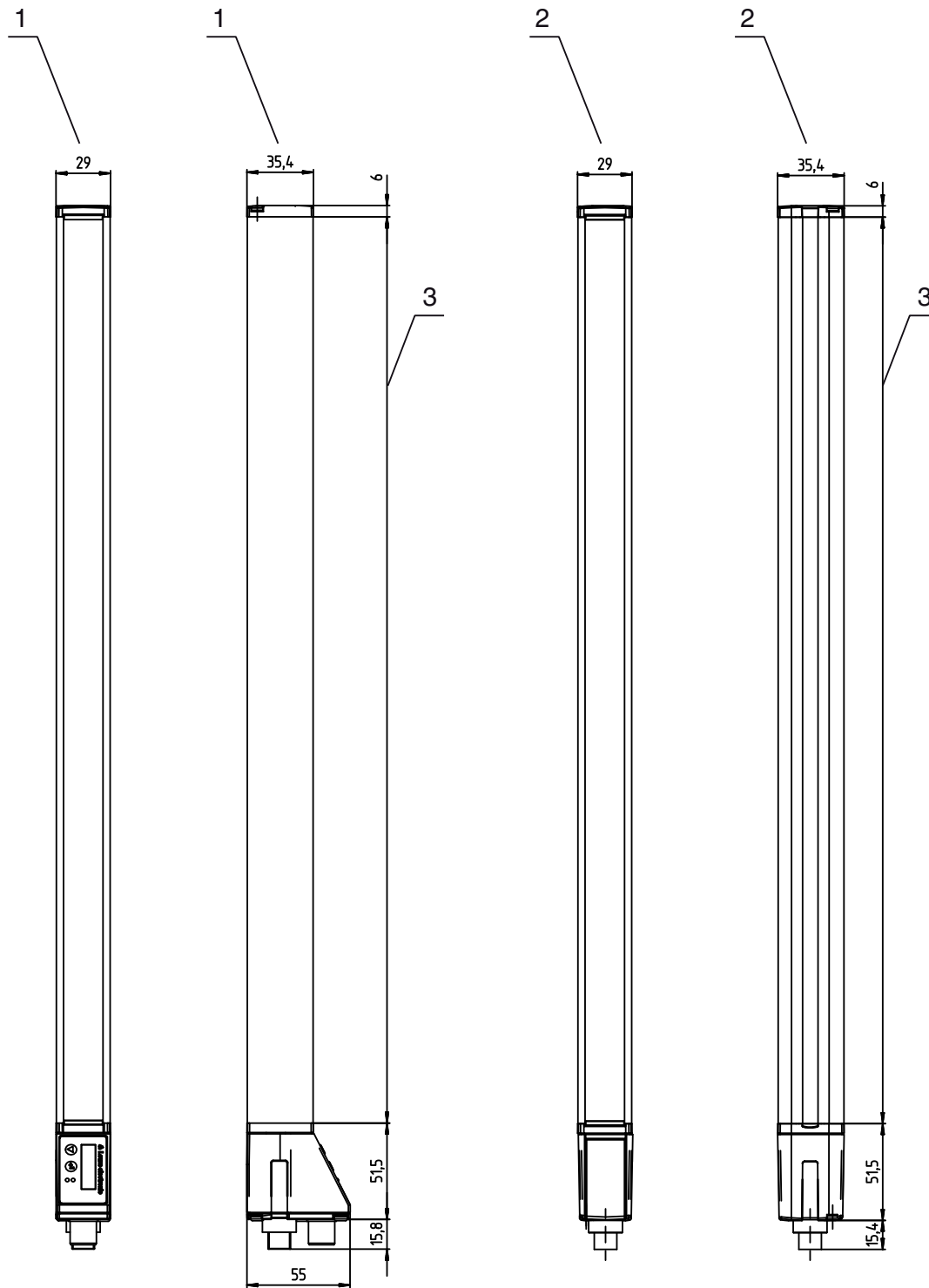

- 1 Receiver
- 2 Transmitter
- 3 Profile length L ((see table 18.4))

Figure 18.1: CML with axial connector outlet

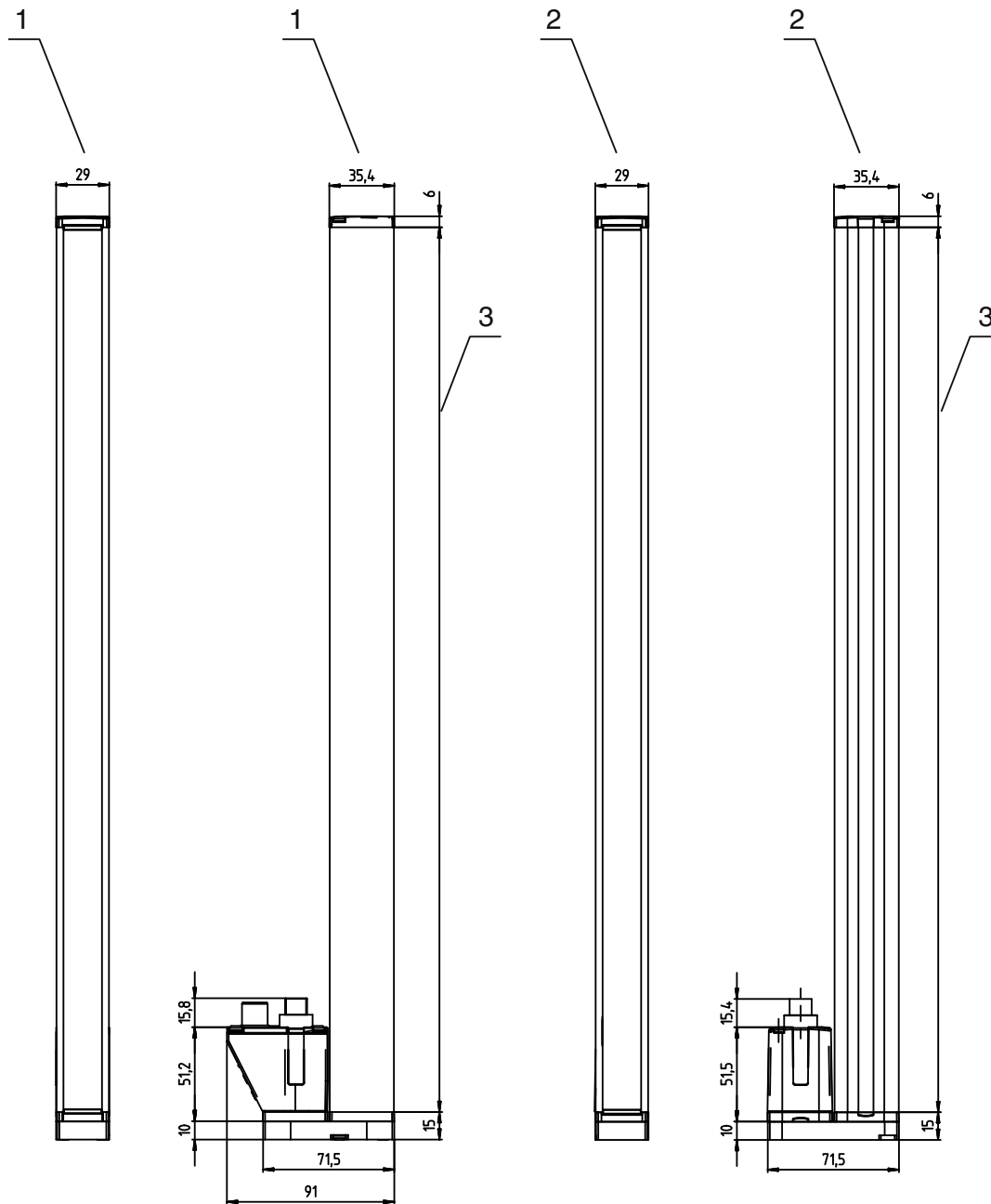

- 1 Receiver
- 2 Transmitter
- 3 Profile length L ((see table 18.4))

Figure 18.2: CML with rear connector outlet

18.4 Dimensional drawings: accessories

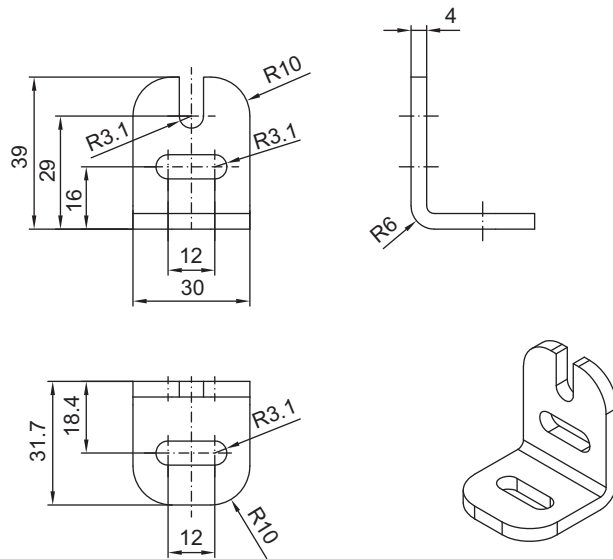

Figure 18.3: BT-2L mounting bracket

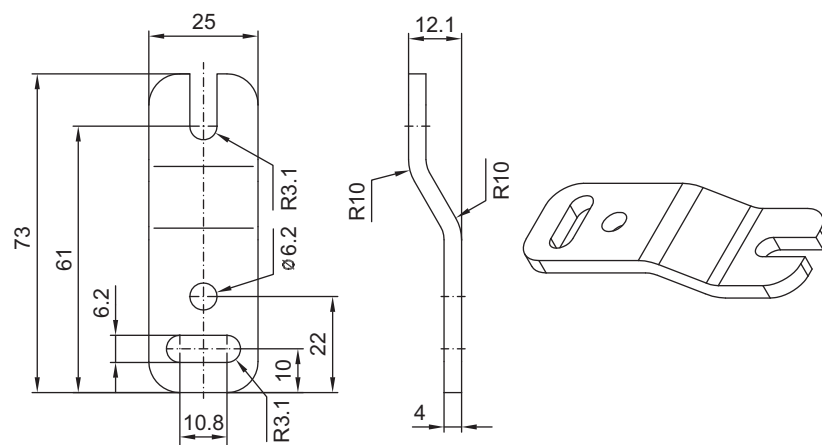

Figure 18.4: BT-2Z parallel bracket

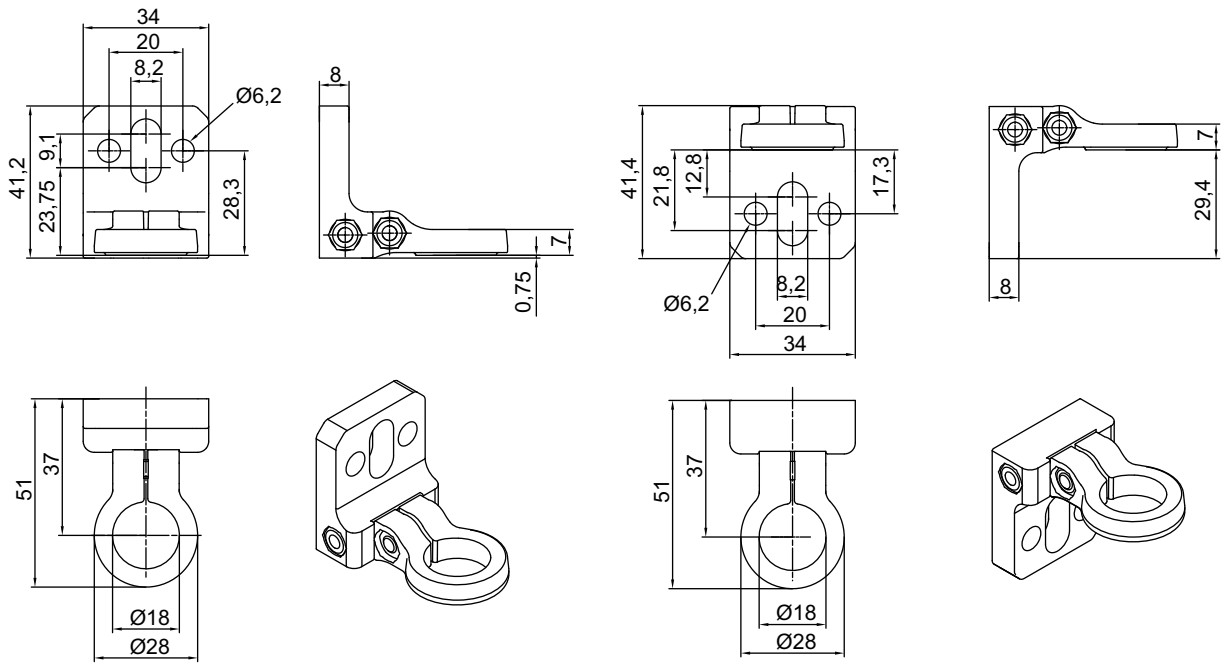

Figure 18.5: BT-2R1 swivel mount (shown in two mounting views)

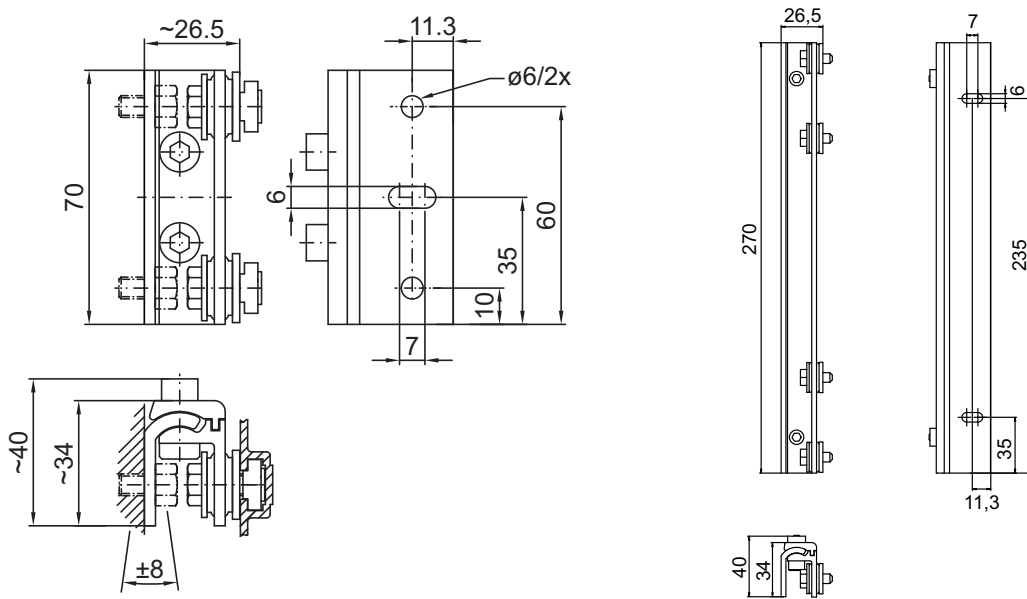

Figure 18.6: BT-2SSD and BT-2SSD-270 swiveling mounting brackets

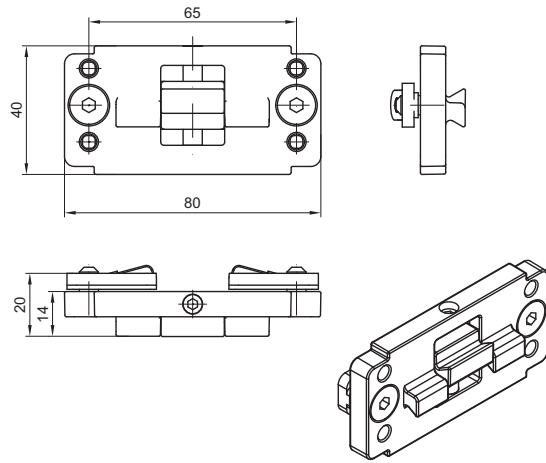

Figure 18.7: BT-2P40 clamp bracket

19 Ordering information and accessories

19.1 Nomenclature

Part designation:

CMLbbb- fss-xxxx.a/ii-eee

Table 19.1: Part number code

| | |
|------|--|
| CML | Operating principle: measuring light curtain |
| bbb | Series: 720 for CML 720i Series: 730 for CML 730i |
| f | Function classes: T: Transmitter R: Receiver |
| ss | Beam spacing: 05: 5 mm 10: 10 mm 20: 20 mm 40: 40 mm |
| xxxx | Measurement field length [mm], dependent on beam spacing: For values see tables |
| a | Equipment: A: axial connector outlet R: rear connector outlet |
| ii | Interface: L: IO-Link CN: CANopen PB: Profibus CV: Analog current and voltage output |
| eee | Electrical connection: M12: M12 connector |

Table 19.2: Part designation, examples

| Part designation | Features |
|---------------------------|--|
| CML720i-T05-1920.A-M12 | CML 720i, transmitter, beam spacing 5 mm, measurement field length 1920 mm, axial connector outlet, M12 connector |
| CML720i-T05-1920.A/CN-M12 | CML 720i, transmitter, beam spacing 5 mm, measurement field length 1920 mm, axial connector outlet, CANopen interface, M12 connector |
| CML730i-R20-2720.R/PB-M12 | CML 730i, receiver, beam spacing 20 mm, measurement field length 2720 mm, rear connector outlet, Profibus interface, M12 connector |

19.2 Accessories

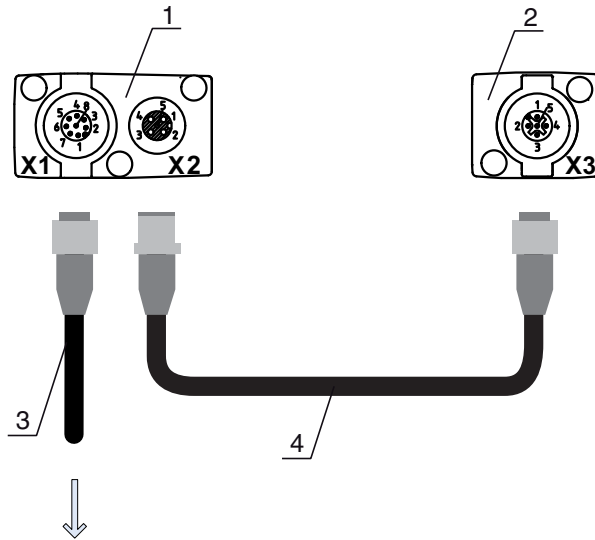

PWR IN/OUT

- 1 Receiver (R)
- 2 Transmitter (T)
- 3 Connection cable (M12 socket, 8-pin)
- 4 Synchronization cable (M12 plug/socket, 5-pin)

Figure 19.1: Electrical connection for IO-Link devices/analog devices

Table 19.3: Accessories - Analog/IO-Link - X1

| Part no. | Part designation | Description |
|---|---------------------|---|
| X1 connection cables for CML, shielded | | |
| 50104591 | K-D M12A-8P-2m-PUR | Connection cable, M12 socket axial, 8-pin, length 2 m, shielded, PUR |
| 50104590 | K-D M12A-8P-5m-PUR | Connection cable, M12 socket axial, 8-pin, length 5 m, shielded, PUR |
| 50106882 | K-D M12A-8P-10m-PUR | Connection cable, M12 socket axial, 8-pin, length 10 m, shielded, PUR |

Table 19.4: Accessories - Analog/IO-Link - X2/X3

| Part no. | Part designation | Description |
|--|--------------------|---|
| X2/X3 connection cables for CML, shielded | | |
| 50114691 | KB DN/CAN-1000 SBA | Connection cable, 5-pin, A-coded, length 1 m, shielded, PUR, M12 socket axial, M12 plug axial |
| 50114694 | KB DN/CAN-2000 SBA | Connection cable, 5-pin, A-coded, length 2 m, shielded, PUR, M12 socket axial, M12 plug axial |
| 50114698 | KB DN/CAN-5000 SBA | Connection cable, 5-pin, A-coded, length 1 m, shielded, PUR, M12 socket axial, M12 plug axial |

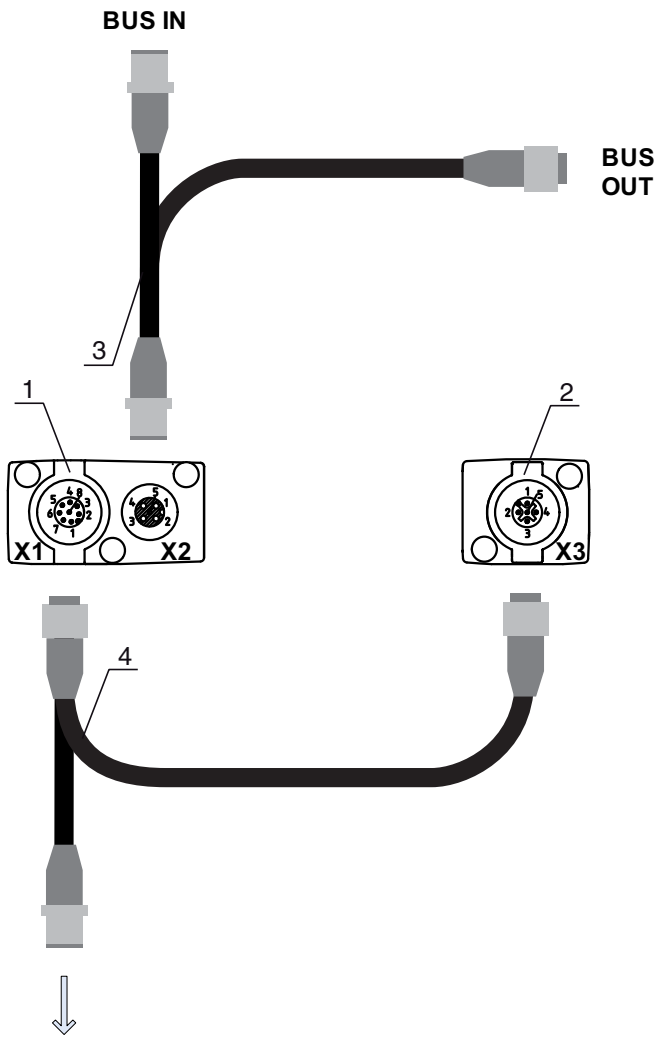

PWR IN/OUT

- 1 Receiver (R)
- 2 Transmitter (T)
- 3 Y-fieldbus cable (M12 plug/socket, 5-pin)
- 4 Y-fieldbus cable and synchronization cable (M12 socket/plug, 8-pin/5-pin)

Figure 19.2: Electrical connection for fieldbus devices

Table 19.5: Accessories - fieldbus - X1/X3

| Part no. | Part designation | Description |
|---|-------------------------|---|
| X1/X3 Y-connection cable and connection cables for CML | | |
| 50118182 | K-Y1 M12A-2m-M12A-S-PUR | Y-connection cable, length 1 m, 5-pin to M12 socket, A-coded, axial, length 150 mm, 5-pin to M12 plug, A-coded, axial, duo-socket M12 axial, 8-pin, PUR |
| 50118183 | K-Y1 M12A-5m-M12A-S-PUR | Y-connection cable, length 5 m, 5-pin to M12 socket, A-coded, axial, length 150 mm, 5-pin to M12 plug, A-coded, axial, duo-socket M12 axial, 8-pin, PUR |

Table 19.6: Accessories - fieldbus - X1

| Part no. | Part designation | Description |
|--|---------------------|---|
| X1 short open cable end of Y-connection cable for CML | | |
| 50104555 | K-D M12A-5P-2m-PVC | Connection cable, M12 socket, A-coded, axial, 5-pin, length 2 m, PVC |
| 50104557 | K-D M12A-5P-5m-PVC | Connection cable, M12 socket, A-coded, axial, 5-pin, length 5 m, PVC |
| 50104559 | K-D M12A-5P-10m-PVC | Connection cable, M12 socket, A-coded, axial, 5-pin, length 10 m, PVC |
| 50104567 | K-D M12A-5P-2m-PUR | Connection cable, M12 socket, A-coded, axial, 5-pin, length 2 m, PUR |
| 50104569 | K-D M12A-5P-5m-PUR | Connection cable, M12 socket, A-coded, axial, 2-pin, length 5 m, PUR |

Table 19.7: Accessories - CANopen fieldbus - X2

| Part no. | Part designation | Description |
|---|--------------------------|---|
| X2 Y-connection cables CANopen for CML | | |
| 50118185 | K-YCN M12A-M12A-S-PUR | Y-connection cable CANopen, A-coded, length 350 mm, 5-pin to M12 socket axial, length 250 mm, 5-pin to M12 plug axial, duo-socket M12 axial, 5-pin, PUR |
| 50118184 | K-YCN M12A-5m-M12A-S-PUR | Y-connection cable CANopen, A-coded, length 5 m, 5-pin to M12 socket axial, length 250 mm, 5-pin to M12 plug axial, duo-socket M12 axial, 5-pin, PUR |

Table 19.8: Accessories - Profibus fieldbus - X2

| Part no. | Part designation | Description |
|--|--------------------------|--|
| X2 Y-connection cables Profibus for CML | | |
| 50123263 | K-YPB M12A-M12A-S-PUR | Y-connection cable Profibus, B-coded, length 350 mm, 5-pin to M12 socket axial, length 250 mm, 5-pin to M12 plug axial, duo-socket M12 axial, 5-pin, PUR |
| 50123265 | K-YPB M12A-5m-M12A-S-PUR | Y-connection cable Profibus, B-coded, length 5 m, 5-pin to M12 socket axial, length 250 mm, 5-pin to M12 connector axial, duo-socket M12 axial, 5-pin, PUR |

Table 19.9: Accessories - fieldbus - termination

| Part no. | Part designation | Description |
|--|------------------|--|
| Termination / bus termination for CML | | |
| 50040099 | TS 01-5-SA | Terminating connector for CANopen (BUS OUT), with integrated terminating resistor |
| 50038539 | TS 02-4-SA | Terminating connector for PROFIBUS (BUS OUT), with integrated terminating resistor |

Table 19.10: Accessories - fastening technology

| Part no. | Part designation | Description |
|----------------------------|------------------|---|
| Mounting technology | | |
| 429056 | BT-2L | L mounting bracket (angled), 2 pieces |
| 429057 | BT-2Z | Z mounting bracket (parallel), 2 pieces |
| 429046 | BT-2R1 | 360° swivel mount, 2 pieces incl. 1 MLC cylinder |
| 429058 | BT-2SSD | Swiveling mounting bracket with shock absorber, ± 8°, 70 mm long, 2 pieces |
| 429059 | BT-4SSD | Swiveling mounting bracket with shock absorber, ± 8°, 70 mm long, 4 pieces |
| 429049 | BT-2SSD-270 | Swiveling mounting bracket with shock absorber, ± 8°, 270 mm long, 2 pieces |
| 424417 | BT-2P40 | Clamp bracket |
| 425740 | BT-10NC60 | Sliding block with M6 thread, 10 pieces |
| 425741 | BT-10NC64 | Sliding block with M6 and M4 thread, 10 pieces |
| 425742 | BT-10NC65 | Sliding block with M6 and M5 thread, 10 pieces |

Table 19.11: Accessories - PC connection configuration

| Part no. | Part designation | Description |
|--------------------------------|----------------------------------|---|
| USB IO-Link master V2.0 | | |
| 50121098 | SET MD12-US2-IL1.1 + accessories | USB-IO-Link master, USB A-B connection cable, plug-in power supply unit (24 V/24 W), CD with software, drivers and documentation) |

19.3 Scope of delivery

- 1 transmitter including 2 sliding blocks
- 1 receiver including 2 sliding blocks
- 1 Connecting and operating instructions (PDF file on CD-ROM)



Connection cables, mounting brackets, IO-Link Device Tool (incl. USB-IO-Link master, etc.) are not included in the delivery contents but must rather be ordered separately.

20 EC Declaration of Conformity

The measuring light curtains of the CML series have been developed and manufactured in accordance with the applicable European standards and directives.

The manufacturer of the product, Leuze electronic GmbH + Co. KG in D-73277 Owen, possesses a certified quality assurance system in accordance with ISO 9001.

