

the sensor people

ODS... 9 / ODS... 96B

Optical distance sensors



Sales and Service

Germany

Sales Region North

Phone 07021/573-306
Fax 07021/9850950Postal code areas
20000-38999
40000-65999
97000-97999

Sales Region South

Phone 07021/573-307
Fax 07021/9850911Postal code areas
66000-96999

Sales Region East

Phone 035027/629-106
Fax 035027/629-107Postal code areas
01000-19999
39000-39999
98000-99999

Worldwide

AR (Argentina)

Condelectric S.A.
Tel. Int. + 54 1148 361053
Fax Int. + 54 1148 361053

AT (Austria)

Schmachtl GmbH
Tel. Int. + 43 732 7646-0
Fax Int. + 43 732 7646-785

AU + NZ (Australia + New Zealand)

Balluff-Leuze Pty. Ltd.
Tel. Int. + 61 3 9720 4100
Fax Int. + 61 3 9738 2677

BE (Belgium)

Leuze electronic nv/sa
Tel. Int. + 32 2253 16-00
Fax Int. + 32 2253 15-36

BG (Bulgaria)

ATICS
Tel. Int. + 359 2 847 6244
Fax Int. + 359 2 847 6244

BR (Brasil)

Leuze electronic Ltda.
Tel. Int. + 55 11 5180-6130
Fax Int. + 55 11 5180-6141

CH (Switzerland)

Leuze electronic AG
Tel. Int. + 41 41 784 5656
Fax Int. + 41 41 784 5657

CL (Chile)

Imp. Tec. Vignola S.A.I.C.
Tel. Int. + 56 3235 11-11
Fax Int. + 56 3235 11-28

CN (China)

Leuze electronic Trading
(Shenzhen) Co. Ltd.
Tel. Int. + 86 755 862 64909
Fax Int. + 86 755 862 64901

CO (Colombia)

Componentes Electronicas Ltda.
Tel. Int. + 57 4 3511049
Fax Int. + 57 4 3511019

CZ (Czech Republic)

Schmachtl CZ s.r.o.
Tel. Int. + 420 244 0015-00
Fax Int. + 420 244 9107-00

DK (Denmark)

Leuze electronic Scandinavia ApS
Tel. Int. + 45 48 173200

ES (Spain)

Leuze electronic S.A.
Tel. Int. + 34 93 4097900
Fax Int. + 34 93 49035820

FI (Finland)

SKS-automaatio Oy
Tel. Int. + 358 20 764-61
Fax Int. + 358 20 764-6820

FR (France)

Leuze electronic Sarl.
Tel. Int. + 33 160 0512-20
Fax Int. + 33 160 0503-65

GB (United Kingdom)

Leuze electronic Ltd.
Tel. Int. + 44 14 8040 85-00
Fax Int. + 44 14 8040 38-08

GR (Greece)

UTECO A.B.E.E.
Tel. Int. + 30 211 1206 900
Fax Int. + 30 211 1206 999

HK (Hong Kong)

Sensortech Company
Tel. Int. + 852 26510188
Fax Int. + 852 26510388

HR (Croatia)

Tipteh Zagreb d.o.o.
Tel. Int. + 385 1 381 6574
Fax Int. + 385 1 381 6577

HU (Hungary)

Kvalix Automatika Kft.
Tel. Int. + 36 1 272 2242
Fax Int. + 36 1 272 2244

ID (Indonesia)

PT. Yabestindo Mitra Utama
Tel. Int. + 62 21 92861859
Fax Int. + 62 21 6451044

IL (Israel)

Galoz electronics Ltd.
Tel. Int. + 972 3 9023456
Fax Int. + 972 3 9021990

IN (India)

M + V Marketing Sales Pvt Ltd.
Tel. Int. + 91 124 4121623
Fax Int. + 91 124 434233

IT (Italy)

Leuze electronic S.r.l.
Tel. Int. + 39 02 26 1106-43
Fax Int. + 39 02 26 1106-40

JP (Japan)

C. Illies & Co., Ltd.
Tel. Int. + 81 3 3443 4143
Fax Int. + 81 3 3443 4118

KE (Kenia)

Profa-Tech Ltd.
Tel. Int. + 254 20 828095/6
Fax Int. + 254 20 828129

KR (South Korea)

Leuze electronic Co., Ltd.
Tel. Int. + 82 31 3828228
Fax Int. + 82 31 3828522

MK (Macedonia)

Tipteh d.o.o. Skopje
Tel. Int. + 389 70 399 474
Fax Int. + 389 23 174 197

MX (Mexico)

Movitren S.A.
Tel. Int. + 52 81 8371 8616
Fax Int. + 52 81 8371 8588

MY (Malaysia)

Ingermark (M) SDN.BHD
Tel. Int. + 60 360 3427-88
Fax Int. + 60 360 3421-88

NG (Nigeria)

SABROW HI-TECH E. & A. LTD.
Tel. Int. + 234 80333 86366
Fax Int. + 234 80333 84463518

NL (Netherlands)

Leuze electronic BV
Tel. Int. + 31 418 65 35-44
Fax Int. + 31 418 65 38-08

NO (Norway)

Eliteco A/S
Tel. Int. + 47 35 56 20-70
Fax Int. + 47 35 56 20-99

PL (Poland)

Balluff Sp. z o. o.
Tel. Int. + 48 71 338 49 29
Fax Int. + 48 71 338 49 30

PT (Portugal)

LA2P, Lda.
Tel. Int. + 351 21 4 447070
Fax Int. + 351 21 4 447075

RO (Romania)

O'BOYLE S.r.l.
Tel. Int. + 40 2 56201346
Fax Int. + 40 2 56221036

RS (Republic of Serbia)

Tipteh d.o.o. Beograd
Tel. Int. + 381 11 3131 057
Fax Int. + 381 11 3018 326

RU (Russian Federation)

ALL IMPEX 2001
Tel. Int. + 7 495 9213012
Fax Int. + 7 495 6462092

SE (Sweden)

Leuze electronic Scandinavia ApS
Tel. Int. + 46 380-490351

SG + PH (Singapore + Philippines)

Balluff Asia Pte Ltd
Tel. Int. + 65 6252 43-84
Fax Int. + 65 6252 90-60

SI (Slovenia)

Tipteh d.o.o.
Tel. Int. + 386 1200 51-50
Fax Int. + 386 1200 51-51

SK (Slovakia)

Schmachtl SK s.r.o.
Tel. Int. + 421 2 58275600
Fax Int. + 421 2 58275601

TH (Thailand)

Industrial Electrical Co. Ltd.
Tel. Int. + 66 2 642 6700
Fax Int. + 66 2 642 4250

TR (Turkey)

Leuze electronic San.ve Tic.Ltd.Sti.
Tel. Int. + 90 216 456 6704
Fax Int. + 90 216 456 3650

TW (Taiwan)

Great Colue Technology Co., Ltd.
Tel. Int. + 886 2 2983 80-77
Fax Int. + 886 2 2985 33-73

UA (Ukraine)

SV Altera OOO
Tel. Int. + 38 044 4961888
Fax Int. + 38 044 4961818

US + CA (United States + Canada)

Leuze electronic, Inc.
Tel. Int. + 1 248 486-4466
Fax Int. + 1 248 486-6699

ZA (South Africa)

Countapulse Controls (PTY) Ltd.
Tel. Int. + 27 116 1575-56
Fax Int. + 27 116 1575-13

1	General information	6
1.1	Explanation of symbols	6
1.2	Important Terms	6
1.3	Declaration of Conformity	8
2	Safety notices	9
2.1	Safety standards	9
2.2	Intended use	9
2.3	Working safely	10
2.3.1	Laser safety notices for the United States and Canada	12
2.4	Organizational measures	13
3	The different sensor types	14
3.1	ODSL 9 with triangulation measurement	14
3.2	ODS... 96B with triangulation measurement	15
3.3	96ODSL 96B/ODKL 96B with time-of-flight measurement principle	15
4	Description ODSL 9	16
4.1	General description	16
4.2	Typical areas of application for the ODSL 9	17
4.3	ODSL 9 variants.....	19
4.3.1	Type code.....	19
4.4	ODSL 9/C or /V with analog output	20
4.4.1	Analog output (factory setting).....	22
4.5	ODSL 9/D with serial output.....	23
4.5.1	Measurement value output for various transmission types.....	23
4.5.2	Commands for remote control operation	25
4.6	ODSL 9/66 with two switching outputs.....	27
5	Description ODS... 96B/ODK... 96B	28
5.1	General description	28
5.2	Typical areas of application for the ODS... 96B/ODK... 96B.....	30
5.3	ODS... 96B/ODK... 96B variants	36
5.3.1	Type code.....	36
5.4	ODS... 96B/ODK... 96B M/C and M/V with analog output	37
5.4.1	Analog output of the red-light/infrared models (factory setting)	39
5.4.2	Analog output of the triangulation laser model (factory setting).....	39
5.4.3	Analog output of the time-of-flight laser model (factory setting)	40
5.5	ODS... 96B/ODK... 96B M/D with serial output	40
5.5.1	Measurement value output for various transmission types.....	41
5.5.2	Commands for remote control operation	42
5.6	ODS... 96B/ODK...96B M/66 with two switching outputs.....	44

6	Installation	45
6.1	Storage, transportation	45
6.2	Mounting	45
7	Operation	48
7.1	Indicator and operating elements.....	48
7.1.1	menu operation	49
7.1.2	LED indicators.....	51
7.2	Switching on.....	51
7.2.1	Reset to factory settings.....	51
7.3	Configuration example - lower switching point.....	52
7.4	Configuration / menu structure.....	53
7.4.1	Input	53
7.4.2	Output Q1	54
7.4.3	Output Q2.....	55
7.4.4	Analog Output	56
7.4.5	Serial	57
7.4.6	Application.....	58
7.4.7	Settings	61
7.5	Teach-in	62
7.5.1	Setting the teach point	62
7.5.2	Teach-in for triangulation sensors	63
7.5.3	Teach-in for time-of-flight sensors	65
7.6	Trigger.....	66
7.7	Measurement modes	66
7.8	Measurement filters	67
7.9	Distance calibration.....	68
7.9.1	Preset or Offset	68
7.9.2	Referencing for triangulation sensors	70
8	Software	71
8.1	Connecting to a PC.....	71
8.2	Installing the configuration software.....	72
8.3	Starting the program	72
8.4	Main window ODS 96B configuration software.....	73
8.5	Configuration window.....	75
8.5.1	Description of the command buttons.....	75
9	Specifications ODSL 9.....	77
9.1	Optical data.....	77
9.2	Electrical data, installation data	78
9.3	Dimensioned and Connection Drawings.....	79

10	Specifications ODS... 96B/ODK... 96B.....	82
10.1	Optical data: triangulation sensors	82
10.2	Optical data: time-of-flight sensors	83
10.3	Electrical data, installation data: triangulation sensors	84
10.4	Electrical data, installation data: time-of-flight sensors	85
10.5	Dimensioned and Connection Drawings	86
11	Type overview and accessories	91
11.1	ODSL 9 type overview	91
11.2	ODS... 96B/ODK... 96B type overview	92
11.2.1	Triangulation sensors	92
11.2.2	Time-of-flight sensors	93
11.3	Accessories ODSL 9	94
11.4	Accessories ODS... 96B/ODK... 96B	95
12	Appendix.....	95
12.1	Updating the ODS configuration software.....	95

Figure 2.1:	Stick-on label with warning notices	11
Figure 4.1:	Indicator and operating elements of the ODSL 9	16
Figure 4.2:	Application example: wood width measurement with the ODSL 9	17
Figure 4.3:	Application example: installation check with the ODSL 9	18
Figure 4.4:	Characteristic output curve ODSL 9 with positive gradient	20
Figure 4.5:	Characteristic output curve ODSL 9 with negative gradient.....	20
Figure 4.6:	Behavior of the ODSL 9 M/C or M/V (laser) analog output	22
Figure 4.7:	Serial transmission formats ODSL 9	24
Figure 4.8:	Behavior of the switching outputs ODSL 9/66	27
Figure 5.1:	Display and operational controls ODS... 96B/ODK... 96B.....	29
Figure 5.2:	Application example: fill level measurement with ODS 96B (TRI).....	30
Figure 5.3:	Application example: stack height measurement with ODSL 96B (TRI)	31
Figure 5.4:	Application example: robot arm positioning with ODSL 96B "S" (TRI).....	32
Figure 5.5:	Application example: Lateral stack positioning with ODSL 96B "XL" (TRI).....	33
Figure 5.6:	Application example: slack control for material on drums with ODSL 96B (TOF)	34
Figure 5.7:	Application example: positioning of side-tracking skates with ODKL 96B (TOF)	35
Figure 5.8:	Characteristic output curve ODS... 96B/ODK... 96B with positive gradient	37
Figure 5.9:	Characteristic output curve ODS... 96B/ODK... 96B with negative gradient.....	37
Figure 5.10:	Behavior of the analog output on the ODS(R) 96B M/C and M/V (red/infrared light). 39	
Figure 5.11:	Behavior of the analog output on the triangulation laser model	39
Figure 5.12:	Behavior of analog output of the time-of-flight laser model	40
Figure 5.13:	ODS... 96B/ODK...96B M/D serial transmission formats	41
Figure 5.14:	Behavior of the switching outputs ODS... 96B/ODK... 96B M/66	44
Figure 6.1:	Preferred direction of entry movement of the objects when using triangulation sensors	46
Figure 6.2:	Preferred mounting of triangulation sensors for structured surfaces.....	46
Figure 6.3:	View through a chase.....	47
Figure 6.4:	Alignment to measurement objects with reflecting surfaces	47
Figure 7.1:	Indicator and operating elements	48
Table 7.1:	LED function indicator	51
Table 7.2:	Input menu	53
Table 7.3:	Menu Output Q1	54
Figure 7.2:	Behavior of the switching outputs.....	54
Table 7.4:	Menu Output Q2.....	55
Table 7.5:	Analog Output menu	56
Table 7.6:	Serial menu	57
Table 7.7:	Application menu.....	58
Table 7.8:	Settings menu	61
Figure 7.3:	Teach signal curve for time-of-flight sensors.....	65
Table 7.11:	Effect of the measurement modes for triangulation sensors	66
Table 7.12:	Effects of the measurement modes for time-of-flight sensors	66
Table 7.13:	Effects of Measure Filter	67
Figure 8.1:	Connecting the distance sensor via the UPG 10 programming terminal.....	71
Figure 8.2:	ODS 96B configuration software - main window	73
Figure 8.3:	ODS 96B configuration software - measurement.....	74
Figure 8.4:	ODS 96B configuration software - configuration window	75
Figure 9.1:	Dimensioned drawing ODSL 9...	79
Figure 9.2:	Electrical connection ODSL 9/C6...	80
Figure 9.3:	Electrical connection ODSL 9/C66...	80

Figure 9.4:	Electrical connection ODSL 9/V6.....	80
Figure 9.5:	Electrical connection ODSL 9/D26... ..	80
Figure 9.6:	Electrical connection ODSL 9/D36... ..	81
Figure 9.7:	Electrical connection ODSL 9/66... ..	81
Figure 10.1:	Dimensioned drawing ODS 96B..., ODSR 96B.....	86
Figure 10.2:	Dimensioned drawing triangulation sensors ODSL(R) 96B.....	87
Figure 10.3:	Dimensioned drawing time-of-flight sensors ODSL 96B.../ODKL 96B.....	88
Figure 10.4:	Electrical connection ODS... 96B/ODK... 96B M/C.....	89
Figure 10.5:	Electrical connection ODS... 96B/ODK... 96B M/C66.....	89
Figure 10.6:	Electrical connection ODS... 96B/ODK... 96B M/V.....	89
Figure 10.7:	Electrical connection ODS... 96B/ODK... 96B M/D26.....	89
Figure 10.8:	Electrical connection ODS... 96B/ODK... 96B M/D36.....	90
Figure 10.9:	Electrical connection ODS... 96B/ODK... 96B M/66... ..	90
Table 11.1:	ODSL 9 type overview.....	91
Table 11.2:	Type overview triangulation sensors ODS... 96B	92
Table 11.3:	Type overview time-of-flight sensors OD...L 96B	93
Table 11.4:	Accessories ODSL 9	94
Table 11.5:	Accessories ODS... 96B/ODK... 96B	95

1 General information

1.1 Explanation of symbols

The symbols used in this technical description are explained below.



Attention

Pay attention to passages marked with this symbol. Failure to heed this information may lead to injuries to personnel or damage to the equipment.



Attention Laser Radiation

This symbol warns of possible danger through hazardous laser radiation.





Notice

This symbol indicates text passages containing important information.



Notice

According to their measurement principle, this manual also refers to the sensors in brief as triangulation sensors and as time-of-flight sensors and partly distinguishes them in the text by means of different colors:

-  **TRI** = triangulation sensors
-  **JLTOF** = time-of-flight sensors

1.2 Important Terms

Absolute measurement accuracy

Shows the possible divergence of the measurement value from the anticipated value through changes in the environmental conditions during the measuring process. Accuracy is increased under constant environmental conditions.

Response time

The time period required to obtain stable measurements after change of the reflectivity behavior. In the case of sensors with the time-of-flight measurement principle, the response time equals the measurement time.

Resolution

The smallest possible distance change of the measured object, which causes a definite change in the output signal. For sensors with triangulation measurement principle, the short range resolution exceeds that at distant range. Objects at short range can be measured with higher accuracy.

Warmup time

Time the sensor needs in order to reach the operating temperature. The warmup time is around 20min (depending on the sensor type). An optimal measurement is only possible after the end of the warmup time.

Delay before start-up

The delay before start-up indicates the point in time when the first valid measurement can be obtained after switching on.

Insensitivity towards ambient light

Indicates the insensitivity of the measurement result towards ambient light. Sensors with triangulation measurement (**TRI**) also measure reliably with external light interference of 5kLux, while the typical light intensity in the workplaces is only about 1kLux. Sensors with time-of-flight measurement principle (**JLTOF**) feature a significantly higher immunity against external light interference of about 100kLux. The immunity against external light interference of triangulation sensors may be improved significantly via the **Ambient Light Suppression** mode (approx. 30kLux).

Light switching / Dark switching

Indicates the behavior of the switching output when an object is inside the taught/configured switching distance. At light switching, the switching output is active (high), at dark switching inactive.

Integration time

The integration time for triangulation sensors is comparable to the exposure time for photographic cameras. It is automatically adjusted to the intensity of the reflected light and thus depends on the reflectance factor of the measured object. It is inversely proportional to the measurement frequency. Triangulation sensors by Leuze electronic automatically adjust themselves for optimum integration time.

Measurement time / measurement frequency

The measurement frequency represents the number of measurements per second. The measurement time indicates the time difference between 2 consecutive measurements. For triangulation sensors, the measurement time changes as a result of the adaptation of the integration time in correspondence with the reflectance and the measurement distance.

Diffuse reflection

Return and/or degree of reflection of the radiated light. Please observe the reflectance values in the respective specifications (90% is white, 6% is black). In the case of sensors with the time-of-flight measurement principle, the measurement range depends on the reflectance.

Time of Flight 

Distance measurement procedures that determines the distance of an object via the propagation time of a light pulse emitted by the sensor's transmitter that is reflected by the object and received by the sensor's receiver. For large operating ranges, high immunity against light interference and low influence of gloss and structures on the measurement value.

Triangulation 

Distance measuring procedure, which determines the distance of an object by the incidence angle of the light reflected from the object. For short to medium operating ranges, fast measurement rate, high accuracy.

Repeatability

Measuring distance change with repeated measurement at the same output signal (observe the same peripheral conditions as with resolution).

1.3 Declaration of Conformity

The optical distance sensors of the ODS.../ODK... series have been manufactured observing current European standards and guidelines.

**Notice**

The corresponding declaration of conformity can be requested from the manufacturer.

The manufacturer of the product, Leuze electronic GmbH + Co. KG in D-73277 Owen, possesses a certified quality assurance system in accordance with ISO 9001.



2 Safety notices

2.1 Safety standards

The optical distance sensors of the series ODS.../ODK... have been developed, manufactured and tested, observing current safety standards. They correspond to the state of the art.

2.2 Intended use



Attention

The protection of personnel and the device cannot be guaranteed if the device is operated in a manner not corresponding to its intended use.

Optical distance sensors of the ODS.../ODK... series are intelligent, configurable sensors for distance measuring.

In particular, unauthorized use includes:

- rooms with explosive atmospheres (zones 0, 1, 20, 21).
- operation for medical purposes



Attention

This product must only be put into operation by qualified personnel and must be used in accordance with its intended purpose. This sensor is not a protective sensor and is not intended for personnel protection.



Notice

For Ex zones 2 and 22, a device of the device category 3 or ignition protection type nA may be used (ask us).

Areas of application

The optical distance sensors of the series ODS.../ODK... have been designed for the following areas of application:

- distance measurement
- contour determination
- thickness measurement
- positioning
- filling level measurement
- diameter determination
- sag determination and much more

2.3 Working safely



Attention Laser Radiation!

The optical distance sensors ODSL.../ODKL... operate with a red light laser of class 2 acc. to EN 60825-1:2007. Sustained exposure to the beam path may damage the eye's retina!

Never look directly into the beam path!

Do not point the laser beam of the ODSL.../ODKL... at persons!

When mounting and aligning the ODSL.../ODKL... , take care to avoid reflections of the laser beam on reflective surfaces!

The use of operating and adjusting devices other than those specified in this technical description, carrying out of differing procedures, or improper use of the optical laser distance sensor may lead to dangerous exposure to radiation!

The use of optical instruments or devices in combination with the device increases the danger of eye damage!

Adhere to the applicable legal and local regulations regarding protection from laser beams acc. to EN 60825-1 in its latest version.

The ODSL.../ODKL... uses a laser diode with low power in the visible red light range with an emitted wavelength of about 655nm.

The glass optics cover is the only opening through which the laser radiation can escape from the device. The device must not be tampered with and must not be changed in any way!



Notice!

It is important that you attach the sticky labels supplied to the device (notice signs and laser emission symbol)! If the signs would be covered due to the installation situation of the OD-SL.../ODKL..., attach them close to the ODSL.../ODKL... in such a way that reading the notices cannot lead to looking into the laser beam!

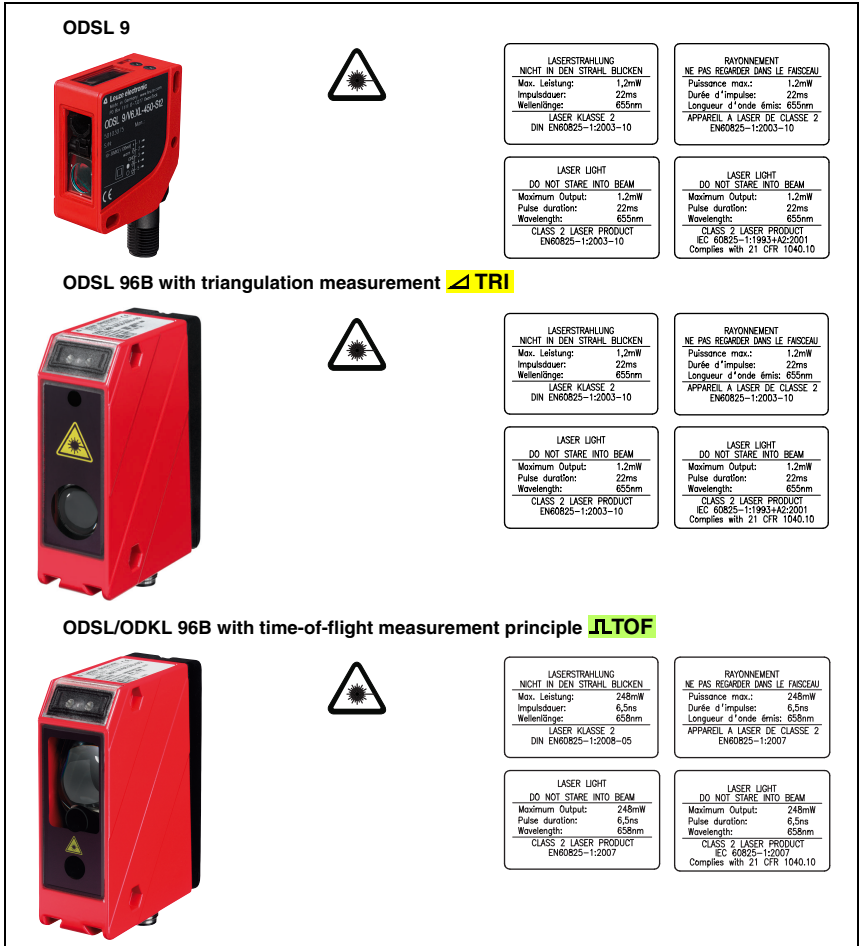

Figure 2.1: Stick-on label with warning notices



Attention

Access and changes to the device, except where expressly described in this operating manual, are not authorized.

2.3.1 Laser safety notices for the United States and Canada



The ODSL.../ODKL... optical distance sensors fulfill the requirements of the safety standard IEC 60825-1:2007 for a Class 2 product. They also fulfill the regulations in accordance with U.S. 21 CFR 1040.10 for a Class II product with the exception of the deviations described in the document "Laser Notice No. 50", dated July 26th, 2001.

Radiated power

The optical distance sensors ODSL.../ODKL... use a low power laser diode in the visible spectrum. The emitted wavelength is:

- 655 nm for ODSL 9.
- 658 nm for ODSL 96B and ODKL 96B.

The peak output power of the laser beam is:

- 1.2mW for ODSL 9.
- 1.2mW for ODSL 96B with triangulation measurement .
- 248mW for ODSL 96B/ODKL 96B with time-of-flight measurement principle .

The radiated power observed at a distance of 20cm through an aperture of 7mm and averaged over a period of 1000s is less than 1 mW acc. to the CDRH Class II specification.

Adjustment and maintenance

Do not attempt to carry out modifications or otherwise interfere with the device. The optical distance sensors contain no parts that need to be adjusted or maintained by the user.

The glass optics cover is the only opening through which the laser radiation can escape from the device.

Warning



The use of operating and adjusting devices other than those specified in this technical description, carrying out of differing procedures, or improper use of the optical laser distance sensor may lead to dangerous exposure to radiation!

The use of optical instruments or devices in combination with the device increases the danger of eye damage!

2.4 Organizational measures

Documentation

All entries in this operating manual must be heeded, in particular those in chapter 2. Carefully store this technical description. It should be accessible at all times.

Safety regulations

Observe the locally applicable legal regulations and the rules of the employer's liability insurance association.

Qualified personnel

Mounting, commissioning and maintenance of the device must only be carried out by qualified personnel. Electrical work must be carried out by a certified electrician.

Repair

Repairs must only be carried out by the manufacturer or an authorized representative.

3 The different sensor types

3.1 ODSL 9 with triangulation measurement

The ODSL 9 is an optical distance sensor that works according to the triangulation measurement principle. Advantages of the triangulation measurement principle:

- Short to medium operating ranges
- High measurement rate
- Very high accuracy
- Measurement against diffusely reflective objects
- Low temperature influence on the measurement value

Overview of sensor features

- Plastic housing with protection class IP 67
- Dimensions 50mm x 50mm x 21mm
- Visible red light laser
- Operating ranges up to 450mm
- Measurement rate 500Hz
- Yellow LC display (backlit) for measurement value display and sensor configuration
- Configuration via PC software and programming unit
- 2 short-stroke keys for menu navigation
- 2 device LEDs

3.2 ODS... 96B with triangulation measurement

The ODSL 96B is an optical distance sensor that works according to the triangulation measurement principle. Advantages of the triangulation measurement principle:

- Medium operating ranges
- High measurement rate
- High accuracy
- Measurement against diffusely reflective objects
- Low temperature influence on the measurement value

Overview of sensor features

- Metal housing with protection class IP 67, IP 69K
- Dimensions 90mm x 70mm x 30mm
- Device variants with red light LED, infrared LED and visible red light laser
- Operating ranges up to 2000mm (range specification in the type designation)
- Measurement rate up to 1 kHz
- Blue OLED display for measurement value display and sensor configuration
- Configuration via PC software and programming unit
- Labeled key pad with 2 buttons for menu navigation
- 2 device LEDs each at the sensor front and back

3.3 96ODSL 96B/ODKL 96B with time-of-flight measurement principle

JLTOF

The ODSL 96B/ODKL 96B is an optical distance sensor that works according to the time-of-flight measurement principle. Advantages of the time-of-flight measurement principle:

- Large operating ranges
- High immunity against light interference
- Low influence of gloss and structures on the measurement value
- Measurement against diffusely reflective objects (ODSL 96B) or reflective tapes (ODKL 96B)
- Wide area of application

Overview of sensor features

- Metal housing with protection class IP 67, IP 69K
- Dimensions 90mm x 70mm x 30mm
- Device variants with red light LED, infrared LED and visible red light laser
- Operating ranges up to 10m diffuse or 25m against high gain foil (no range specification in the type designation)
- Measurement rate up to 800Hz
- Blue OLED display for measurement value display and sensor configuration
- Configuration via PC software and programming unit
- Labeled key pad with 2 buttons for menu navigation
- 2 device LEDs each at the sensor front and back

4 Description ODSL 9

4.1 General description

The ODSL 9 is a distance sensor with an extensive area of application. The devices are available as a laser version with analog output or serial output as well as with 1 to 2 switching outputs. The distance measuring device works on the triangulation principle and uses a CCD line for evaluating.

Through automatic adjustment of the integration time (exposure time) to the intensity of the objects' reflected light, a high degree of independence from the reflectivity properties of the measured object is achieved.

An integrated RISC controller facilitates brief measurement times while at the same time providing highly precise measurement values. The high-performance hardware is also able to preprocess measurement data directly in the sensor.

The standard measurement range is 50 ... 450mm at a resolution of 0.1 mm. A higher resolution version is available with a measurement range of 50 ... 100mm at a resolution of 0.01 mm.

Two short-stroke keys and a backlit LC display are integrated into the device. They allow the ODSL 9 to be configured via a graphical menu (as for ODS...96B). During measurement operation, the display shows the current measurement value. The sensor can be protected against unauthorized operation via an optional control guard and password protection.

The ODS 96B configuration software available from www.leuze.de allows configuration of the ODSL 9 products by means of a PC and visualization of the ODSL 9's measurement values. Moreover, stored parameter sets can be duplicated in other distance sensors. The connection is made via the programming adapter, which is available as an accessory (UPG10).



Figure 4.1: Indicator and operating elements of the ODSL 9

Accessories

The ODS 96B configuration software as well as a UPG 10 programming adapter are available for configuring the ODSL 9 from a PC.

For the ODSL 9 distance sensors, mounting accessories of series 8 may be used. Connection cables in various lengths and configurations round off the accessories. Details can be found in chapter 11.

4.2 Typical areas of application for the ODSL 9

Typical areas of application for the ODSL 9 are:

- Positioning of actuators and robots
- Height and width measurement as well as determination of diameter
- Quality assurance in assembly lines
- Contour measurement of moving objects

Laser light spot: 1 mm x 1 mm



Application examples



Figure 4.2: Application example: wood width measurement with the ODSL 9



Figure 4.3: Application example: installation check with the ODSL 9



Notice

For mounting instructions please refer to chapter 6.2.

4.3 ODSL 9 variants

Variants

The ODSL 9 is available as a **laser distance sensor** (red light):

Measurement ranges: 50 ... 100mm with absolute measurement accuracy $\pm 0.5\%$, resolution 0.01 mm
 50 ... 450mm with absolute measurement accuracy $\pm 1.0\%$, resolution 0.1 mm

4.3.1 Type code



Use the following table to determine the equipment features of your ODSL 9.

ODSL 9/ C6-450 -S12		
Connection type	S12	M12 connector
Operating range in mm ( TRI)	100	50 ... 100mm, High Res., resolution 0.01 mm
	450	50 ... 450mm, resolution 0.1 mm
Switching output	6	1 push/pull output
	66	2 push/pull outputs
	C	analog current output
Measurement data output	V	analog voltage output
	D2	serial RS 232 output
	D3	serial RS 485 output
Light source	L	laser
Target object	S	measurement against diffusely reflective objects
	OD	optical distance sensor



Notice

According to their measurement principle, this manual also refers to the sensors in brief as triangulation sensors and as time-of-flight sensors and partly distinguishes them in the text by means of different colors:

-  **TRI** = triangulation sensors
-  **LTOF** = time-of-flight sensors

4.4 ODSL 9/C or /V with analog output

Characteristic output curves for ODSL 9

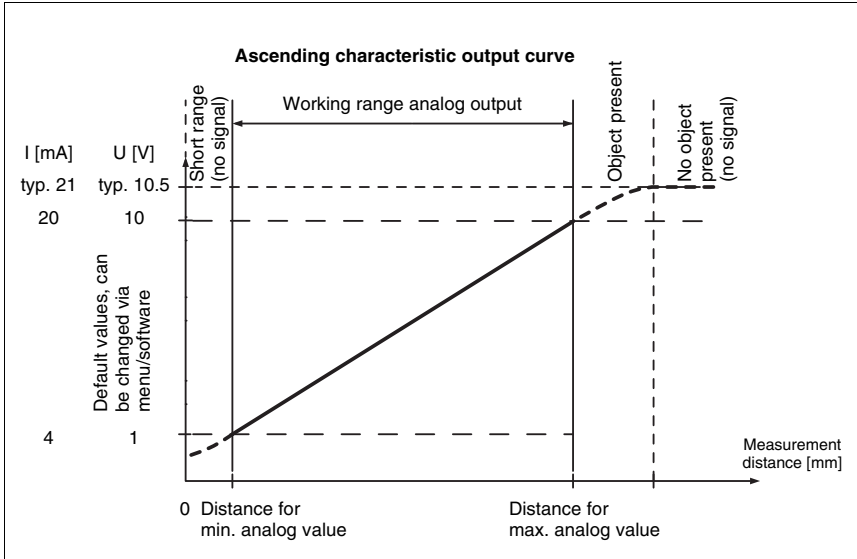

Figure 4.4: Characteristic output curve ODSL 9 with positive gradient

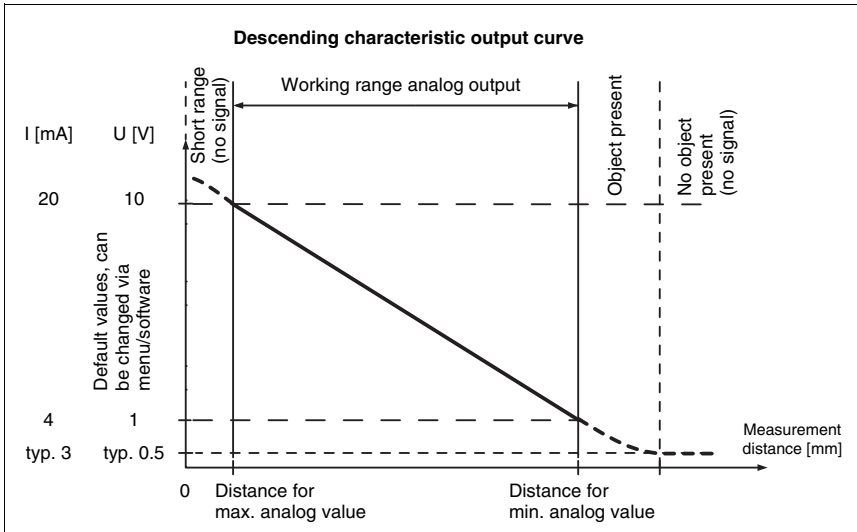

Figure 4.5: Characteristic output curve ODSL 9 with negative gradient

Behavior of the analog output

The ODSL 9 M/C or M/V has an analog output with linear behavior inside of the respective measurement range. Above and below the linear range, linearity is lost however, the output values signify an upper deviation ($> 20\text{mA}$ respectively $> 10\text{V}$) or a lower deviation ($< 4\text{mA}$ respectively $< 1\text{V}$) of the measurement range.

For ODSL 9 models with voltage output, it is also possible to set the voltage range of the output.

The analog output can be easily configured using the LC display or via software. In order to achieve the highest resolution possible, the range of the analog output should be set as small as the application allows. The characteristic output curve can be configured with a positive or negative gradient. For this purpose, the two distance values `Position Min. Val.` and `Position Max. Val.` are set appropriately for the minimum and maximum analog output values, see figure 4.4 and figure 4.5.

Alternatively, the analog output can also be taught via pin 2 (see chapter "Teach-in of the switching outputs/characteristic output curve (time control)").

Behavior of the switching output

In addition, a switching output is also available with the ODSL 9 M/C and M/V. The position within the measuring range at which the switching output becomes active can be set arbitrarily via a teach line or via configuration. In addition to the switching point, it is also possible to set the switching hysteresis and switching behavior (light/dark switching) using the short-stroke keys or the configuration software.

Teach-in of the characteristic output curve

In addition to edge-controlled **teach-in of the switching outputs** (slope control), the ODSL 9 with analog output can also be used to perform a time-controlled **teach-in of switching output and characteristic output curve** (time control) via the teach line. Both teach events are described in chapter 7.5.

4.4.1 Analog output (factory setting)

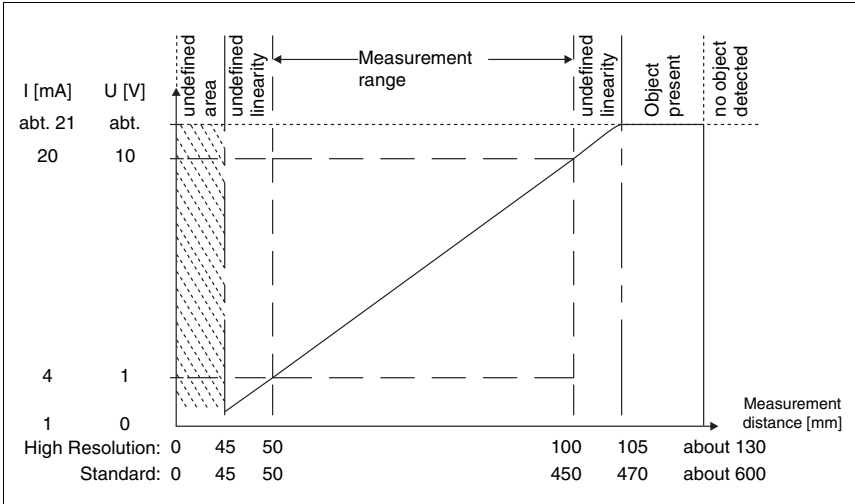

Figure 4.6: Behavior of the ODSL 9 M/C or M/V (laser) analog output

4.5 ODSL 9/D with serial output

The ODSL 9/D... is equipped with one switching output and one serial interface, which is implemented either as an RS 232 interface (ODSL 9/D2...) or as an RS 485 interface (ODSL 9/D3...).

The transmission rate can be set to between 9,600 and 57,600 baud.

Serial transmission is performed with **1 start bit, 8 data bits** and **1 stop bit without parity**.

For the transmission of the measurement values, 4 different transmission modes may be configured (see figure 4.7):

- **ASCII measurement value**
(6 bytes)
- **14-bit measurement value**
(2 bytes, ODS 96 compatible)
- **16-bit measurement value**
(3 bytes, ODSL 30 compatible)
- **Remote control operation**

4.5.1 Measurement value output for various transmission types

Object distance	Measurement value output
No evaluable receive signal	0
< Measurement range	distance value (undefined linearity)
Within measurement range	distance value linear
> Measurement range	distance value (undefined linearity)
Device error	0

Measurement value ASCII transmission

Transmission format: **MMMMM<CR>**

MMMMM = 5-digit measurement value in mm (for sensors with 1 mm output resolution)

or = 5-digit measurement value in 0.1 mm (for 0.1 mm output resolution)

<CR> = ASCII character "Carriage Return" (x0D)

Measurement value = 14-bit (ODS 96 compatible)

Measurement ranges up to 1400mm, output resolution 0.1 mm / Measurement ranges up to 2000mm, output resolution 1 mm

1. Low Byte (bit 0 = 0)



bit 6
bit 5
bit 4
bit 3
bit 2
bit 1
bit 0 (LSB)

2. High Byte (bit 0 = 1)



bit 13 (MSB)
bit 12
bit 11
bit 10
bit 9
bit 8
bit 7

Measurement value = 16-bit (ODSL 30 compatible)

Measurement ranges up to 1400mm, output resolution 0.1 mm / Measurement ranges up to 2000mm, output resolution 1 mm

1. Low Byte (bit 0 = 0, bit 1 = 0)



bit 5
bit 4
bit 3
bit 2
bit 1
bit 0 (LSB)

2. Middle Byte (bit 0 = 1, bit 1 = 0)



bit 11
bit 10
bit 9
bit 8
bit 7
bit 6

3. High Byte (bit 0 = 0, bit 1 = 1)



don't care
don't care
bit 15 (MSB)
bit 14
bit 13
bit 12

Remote control

ASCII transfer of the measurement value on request

4 digits (4 bytes) or **5 digits** (5 bytes).

Figure 4.7: Serial transmission formats ODSL 9

4.5.2 Commands for remote control operation

For remote-control operation (Serial -> Com Function -> Remote control), a device address can be set between 0 and 14 (Serial -> Node Address). In this operating mode, the ODSL 9/D only responds to commands from the control. The following control commands are available:

4-digit measurement value query (ODS 96 compatible):

	Byte no.									Response time	
	0	1	2	3	4	5	6	7	8		
Command	Sensor address 0x00 through 0x0E	-	-	-	-	-	-	-	-		
Sensor response	"*#" (0x2A)	ASCII address tens	ones	ASCII distance measurement value 1'000's		100's	tens	ones	"##" (0x23)	-	max. 15ms

5-digit measurement value query (ODSL 30 compatible):

	Byte no.									Response time
	0	1	2	3	4	5	6	7	8	
Command	"*#" (0x2A)	ASCII address "0...9", "A...D"	"M" (0x4D)	"#" (0x23)	-	-	-	-	-	
Sensor response	"*#" (0x2A)	ASCII address "0...9", "A...D"	10'000's	1'000's	100's	tens	ones	State	"##" (0x23)	max. 15ms

Execute referencing function:

	Byte no.									Response time
	0	1	2	3	4	5	6	7	8	
Command	"*#" (0x2A)	ASCII address "0...9", "A...D"	"R" (0x52)	"#" (0x23)	-	-	-	-	-	
Sensor response	"*#" (0x2A)	ASCII address "0...9", "A...D"	State	"#" (0x23)	-	-	-	-	-	max. 2s

Detailed information on referencing can be found in chapter 7.9.2

Execute preset measurement:

	Byte no.									Response time
	0	1	2	3	4	5	6	7	8	
Command	"*#" (0x2A)	ASCII address "0...9", "A...D"	"P" (0x52)	"#" (0x23)	-	-	-	-	-	
Sensor response	"*#" (0x2A)	ASCII address "0...9", "A...D"	State	"#" (0x23)	-	-	-	-	-	max. 2s

Detailed information on presets/offsets can be found in chapter 7.9.1

Activate sensor:

	Byte no.									Response time
	0	1	2	3	4	5	6	7	8	
Command	"*" (0x2A)	ASCII address "0...9", "A...D"	"A" (0x41)	"#" (0x23)	-	-	-	-	-	
Sensor response	"*" (0x2A)	ASCII address "0...9", "A...D"	State	"#" (0x23)	-	-	-	-	-	max. 15ms

Deactivate sensor:

	Byte no.									Response time
	0	1	2	3	4	5	6	7	8	
Command	"*" (0x2A)	ASCII address "0...9", "A...D"	"D" (0x44)	"#" (0x23)	-	-	-	-	-	
Sensor response	"*" (0x2A)	ASCII address "0...9", "A...D"	State	"#" (0x23)	-	-	-	-	-	max. 15ms

Status byte (bitwise processing):

Bit number	Meaning
7 (MSB)	always = 0 (reserved)
6	1 = other error (e.g. no measurement possible or referencing / preset not successful), 0 = OK
5	always = 1
4	always = 0 (reserved)
3	always = 0 (reserved)
2	1 = sensor deactivated, 0 = sensor activated
1	1 = no signal or signal too low, 0 = signal OK
0 (LSB)	1 = Laser interference, 0 = Laser OK

4.6 ODSL 9/66 with two switching outputs

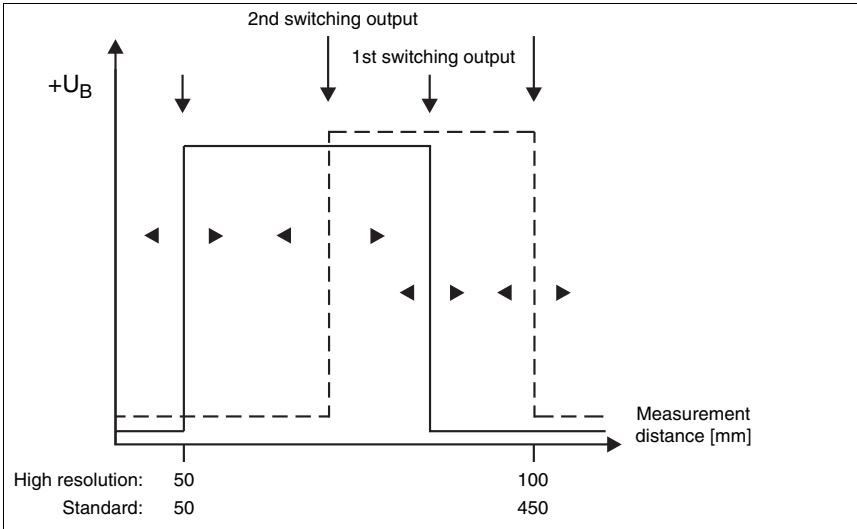

Figure 4.8: Behavior of the switching outputs ODSL 9/66

The two switching outputs of the ODSL 9/66 work independently of each other. Upper and lower switching points as well as hysteresis for both switching outputs can be set separately via the LC display or the ODS 96B configuration software.

Via the teach input, either the upper or the lower measurement range limit can be taught for both switching outputs or, alternatively, the center of the switching range. An exact description of the teach event can be found in chapter 7.5.

A common teach line is available for both switching outputs, meaning the switching outputs are taught alternately (for slope-control teach-in). The presently taught output is displayed through the simultaneous or alternating flashing of the LEDs (see chapter 7.5).

5 Description ODS... 96B/ODK... 96B

5.1 General description

The ODS... 96B/ODK... 96B is a distance measuring device with a large area of application. The devices are available as LED or laser version with analog or serial output. Two different measurement principles are applied:

Measurement principle: Triangulation

When using the triangulation measuring procedure, the distance of an object is determined via the angle of incidence of the light reflected by the object. For the actual measurement, a linear CCD array is used. The measurement principle is suitable for medium operating ranges and permits a fast measurement rate and high accuracy.

Through automatic adjustment of the integration time (exposure time) to the intensity of the objects' reflected light, a high degree of independence from the reflectivity properties of the measured object is achieved. In case of low reflectivity (dark objects) a longer measurement time results. The sensor sets the measurement time automatically.

The measurement range extends from 60 - 2,000mm (depending on sensor model).

Measurement principle: time-of-flight

In the time-of-flight measurement procedure, the distance of an object is determined via the propagation time of a light pulse emitted by the sensor's transmitter that is reflected by the object and received by the sensor's receiver. The measurement principle is suitable for large operating ranges with simultaneous immunity to light interference and a low influence of gloss and structures on the measurement value. The measurement time can be adjusted via the configuration software ODS 96B or via key pad and OLED display. It remains fixed.

The measurement range extends from 300 - 25,000mm (depending on sensor model).





Notice

The type designation indicates which measurement principle your sensor uses:

- **Sensors with triangulation measurement principle include an operating range specification in the type designation. Example: ODSL 96B M/C6-2000-S12.**
- **Sensors with time-of-flight measurement principle do not include an operating range specification in the type designation. Example: ODSL 96B M/C6-S12.**

According to their measurement principle, the sensors are in the following also referred to in brief as triangulation sensors and as time-of-flight sensors and are partly distinguished in the text by means of different colors:

-  = triangulation sensors
-  = time-of-flight sensors

All device variants feature an integrated RISC controller for brief measurement times with simultaneous high precision measurement values. The high-performance hardware is also able to preprocess measurement data directly in the sensor.

A key pad and an OLED display are integrated into the device, which allow the ODS... 96B/ODK... 96B to be configured via a graphical menu. During measurement operation, the display shows the current measurement value. A lockable cover on the back of the ODS... 96B/ODK... 96B and password protection safeguard the sensor against unauthorized operation.

The ODS 96B configuration software available from www.leuze.com allows configuration of the ODS... 96B/ODK... 96B sensors with a PC and visualization of the measured values. Moreover, stored parameter sets can be duplicated in other distance sensors. The connection is made via the programming adapter, which is available as an accessory (UPG10).



Figure 5.1: Display and operational controls ODS... 96B/ODK... 96B

Accessories

The ODS 96B configuration software as well as a UPG 10 programming adapter are available for configuring ODS... 96B/ODK... 96B from a PC.

The housing dimensions of the ODS... 96B/ODK... 96B distance sensors are identical to those of the sensors of the series 96 from Leuze electronic. In particular, the mounting accessories of the series 96 can be used for the ODS... 96B/ODK... 96B.

For ODKL 96B sensors, a special high-gain reflective tape is available.

Connection cables in various lengths and configurations round off the accessories.

Details can be found in chapter 11.

5.2 Typical areas of application for the ODS... 96B/ODK... 96B

Due to the high number of sensor models and light spot geometries, the ODS... 96B/ODK... 96B is suitable for nearly all areas of application.



Notice

For mounting instructions please refer to chapter 6.2.

ODS 96B with infrared or red light LED, measurement range 100 ... 1400mm ():

- Measurement on large surface objects, e.g., bulk material, material on drums, sheet material
- brightVision® – very bright light spot with LED red light

LED light spot: 15mm x 15mm



Application example

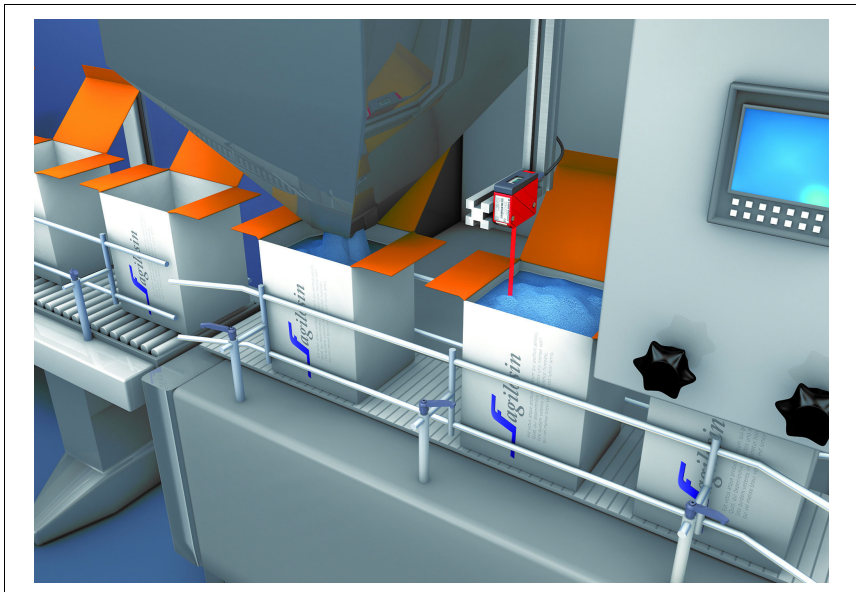

Figure 5.2: Application example: fill level measurement with ODS 96B (TRI)

ODSL 96B with laser, measurement range 60 ... 2000mm ():

- Measurement in millisecond cycles for large operating ranges
- Stable and precise measurement values, even at varying temperatures and object variations

Laser light spot: 2mm x 6mm



Application example

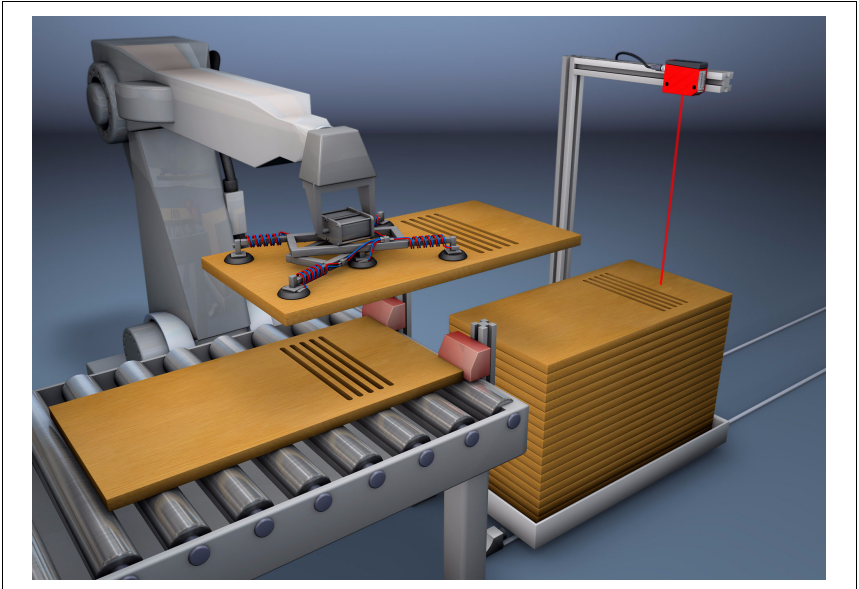

Figure 5.3: Application example: stack height measurement with ODSL 96B (TRI)

ODSL 96B "S" with laser, measurement range 150 ... 800 mm ():

- Small laser light spot for the precise measurement onto small objects, metallic surfaces or objects with color structures

Laser light spot: 1 mm x 1 mm



Application example

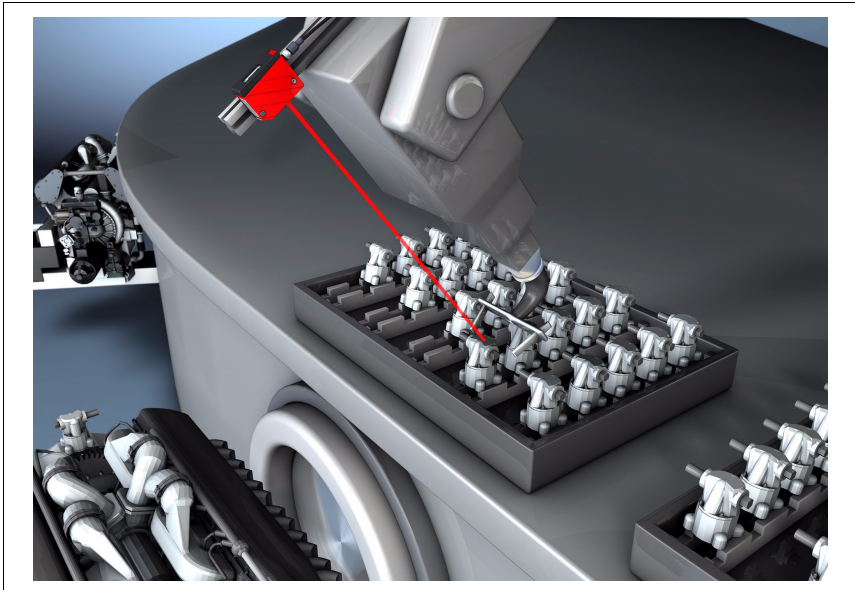

Figure 5.4: Application example: robot arm positioning with ODSL 96B "S" (TRI)

ODSL 96B "XL" with laser, measurement range 150 ... 1200mm ():

- Elongated light spot for precise measurement on perforated or porous objects (e.g., corrugated cardboard), and on objects that are not precisely aligned

Laser light spot: 15 mm x 4 mm (at 800mm distance)



Application example

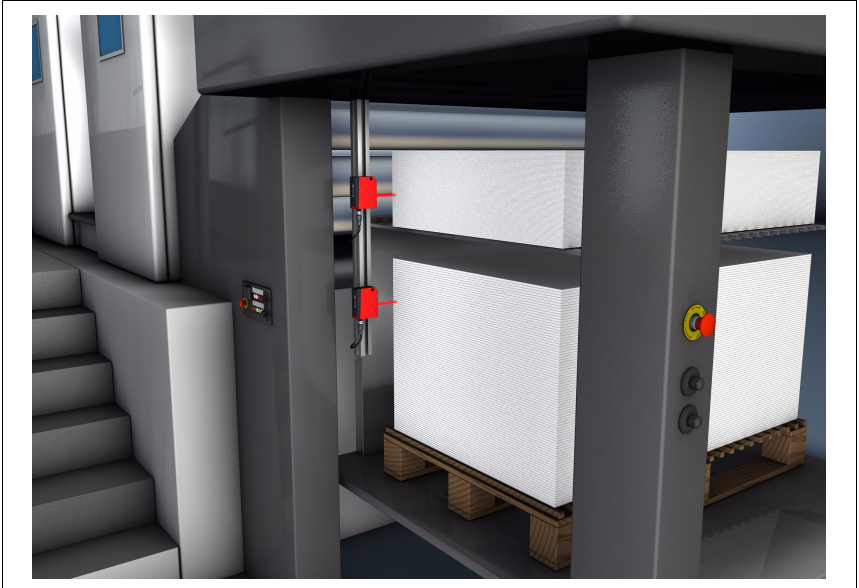

Figure 5.5: Application example: Lateral stack positioning with ODSL 96B "XL" (TRI)

ODSL 96B with laser for measurement on objects, measurement range 0.3 ... 10m (**JLTOF**):

- Large operating range, even for dark objects
- Operating modes for fast or precise measurement

Laser light spot: 2 mm x 6 mm (at 5 m distance)



Application example

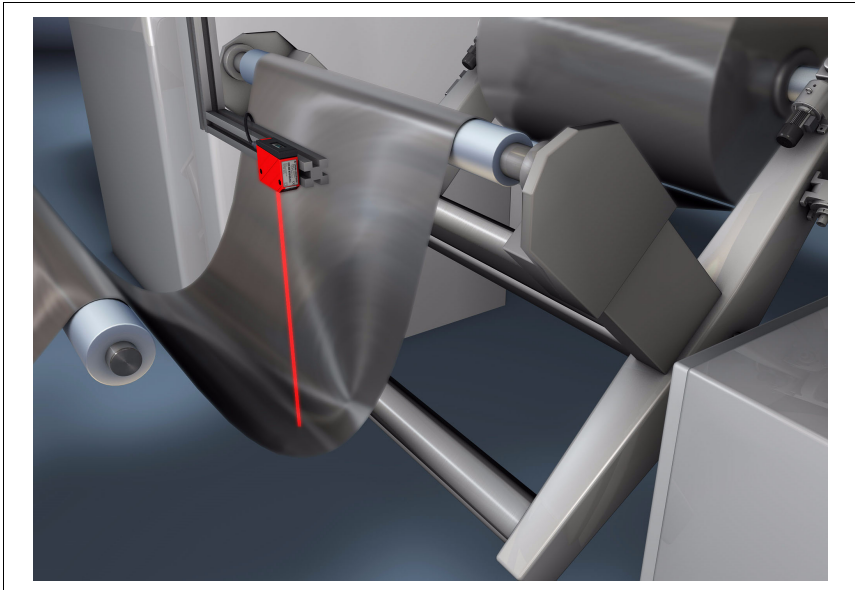

Figure 5.6: Application example: slack control for material on drums with ODSL 96B (TOF)

ODSL 96B with laser for measuring on reflective tape, measurement range 0.3 ... 25m (JLTOF):

- Fast and easy alignment due to well visible laser light spot
- Large operating range in compact design

Laser light spot: 2mm x 6mm (at 5m distance)



Application example

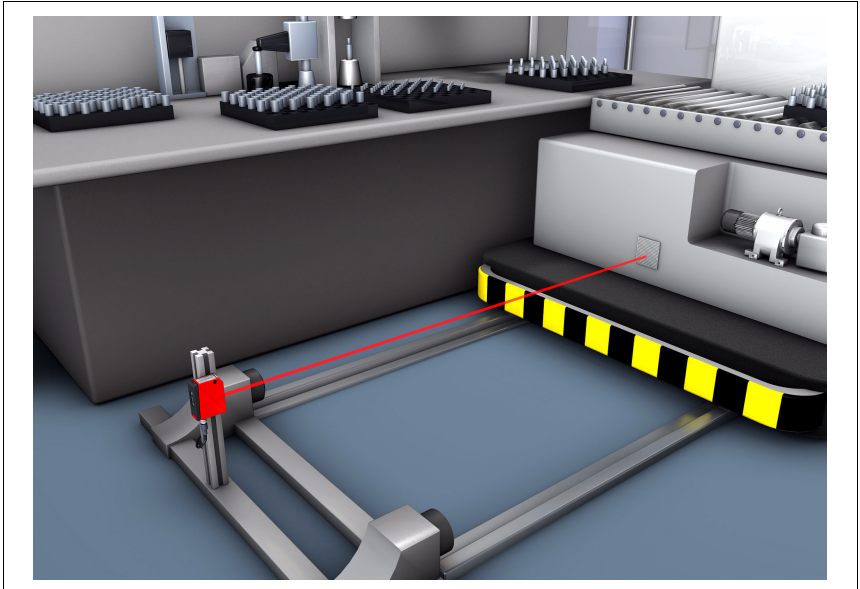











Figure 5.7: Application example: positioning of side-tracking skates with ODKL 96B (TOF)

5.3 ODS... 96B/ODK... 96B variants



Variants

Four different base variants of the ODS... 96B/ODK... 96B are available:

- as **infrared distance sensor ODS 96B**
 measurement ranges: 100 ... 600mm 
 120 ... 1400mm 
- as **red-light distance sensor ODSR 96B**
 measurement range: 100 ... 600mm 
- as **laser distance sensor (red light) ODSL(R) 96B** for measurement of diffusely reflective objects
 Measurement range: 150 ... 800mm  (laser, "S" light spot)
 150 ... 1200mm  (laser, "XL" light spot)
 60 ... 2000mm  (laser + red light LED)
 150 ... 2000mm  (laser)
 300 ... 10,000mm  (laser)
- as **laser distance sensor (red light) ODKL 96B** for the measurement of high-gain reflective tape
 Measurement range: 300 ... 25,000mm  (Laser onto reflective tape)

5.3.1 Type code

Use the following table to determine the equipment features of your ODS... 96B/ODK... 96B.

OD S L 96B M/C 6-2000-S12	
Connection type	S12 M12 connector
Operating range in mm	2000 150 ... 2000mm (laser with light spot 2 x 6mm) 60 ... 2000mm (red-light LED and laser)
	1400 120 ... 1400mm (infrared LED)
	 1200 150 ... 1200mm (laser with light spot 15 x 4mm)
	800 150 ... 800mm (laser with light spot dia. 1mm)
	600 100 ... 600mm (infrared LED or red-light LED)
Without value	300 ... 25,000mm (laser onto reflective tape)
	 300 ... 10,000mm (laser)
Switching output	6 1 push/pull output
	66 2 push/pull outputs
Measurement data output	C analog current output
	V analog voltage output
	D2 serial RS 232 output
	D3 serial RS 485 output
Light source	infrared LED
	R red-light LED
	L laser
	LR red-light LED and laser
Target object	S measurement against diffusely reflective objects
	K measurement against high-gain reflective tape
	OD optical distance sensor

5.4 ODS... 96B/ODK... 96B M/C and M/V with analog output

Characteristic output curves for the ODS... 96B/ODK... 96B

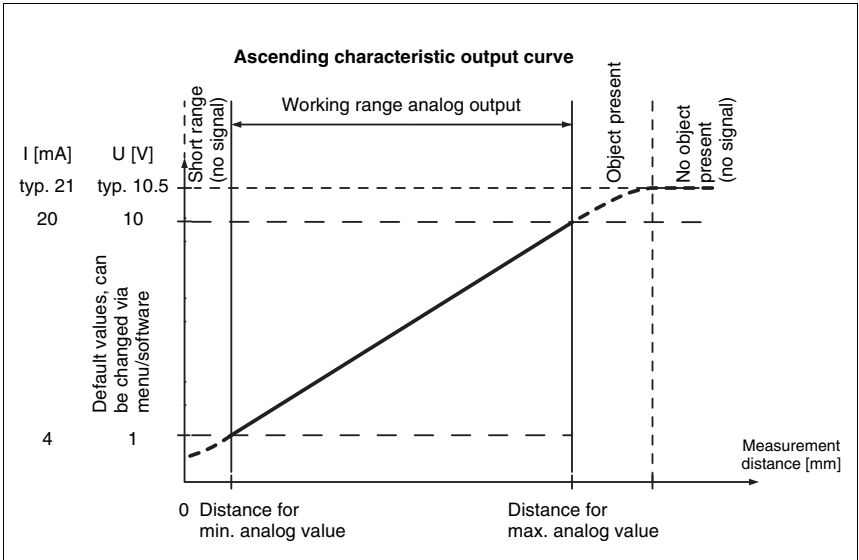

Figure 5.8: Characteristic output curve ODS... 96B/ODK... 96B with positive gradient

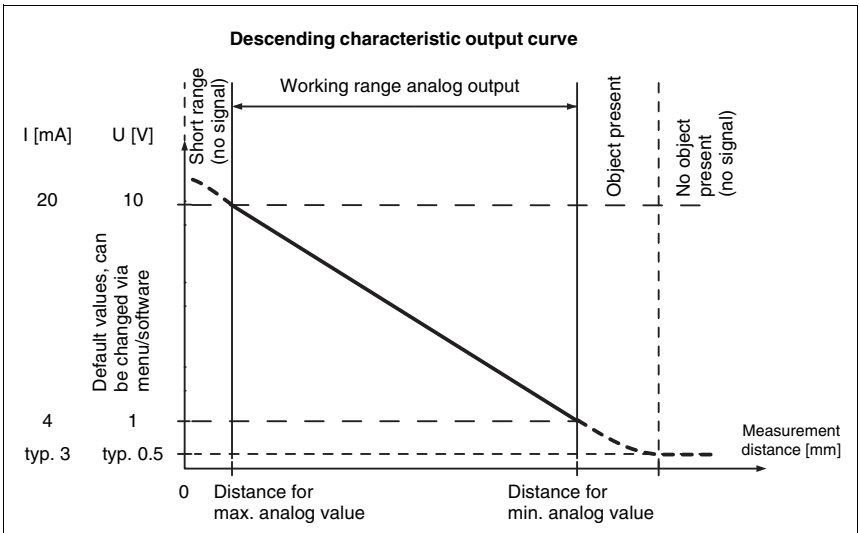

Figure 5.9: Characteristic output curve ODS... 96B/ODK... 96B with negative gradient

Behavior of the analog output

The ODS... 96B/ODK... 96B M/C or M/V has an analog output with linear behavior inside of the respective measurement range. Above and below the linear range, linearity is lost however, the output values signify an upper deviation ($> 20\text{mA}$ respectively $> 10\text{V}$) or a lower deviation ($< 4\text{mA}$ respectively $< 1\text{V}$) of the measurement range.



For the models with voltage output, it is also possible to set the voltage range of the output. The analog output can be easily configured using the OLED display or via software. In order to achieve the highest resolution possible, the range of the analog output should be set as small as the application allows. The characteristic output curve can be configured with a positive or negative gradient. For this purpose, the two distance values *Position Min. Val.* and *Position Max. Val.* are set appropriately for the minimum and maximum analog output values, see figure 5.8 and figure 5.9.

Alternatively, the analog output can also be taught via pin 2 (see chapter 7.5 "Teach-in").

Behavior of the switching output

In addition, a switching output is also available with the ODS... 96B/ODK... 96B M/C and M/V. The position within the measuring range at which the switching output becomes active can be set arbitrarily via a teach line or via configuration. In addition to the switching point, it is also possible to set the switching hysteresis and switching behavior (light/dark switching) using the key pad or the configuration software.

Teach-in of the characteristic output curve

There are different teach methods depending on the device model ( **TRI** or  **LTOF**):

-  **TRI**:

In addition to edge-controlled **teach-in of the switching outputs** (slope control), the ODS... 96B with analog output can also be used to perform a time-controlled **teach-in of switching output and characteristic output curve** (time control) via the teach line. Both teach events are described in chapter 7.5.2.

-  **LTOF**:

For the ODS... 96B with time-of-flight measurement principle, there is only a time-controlled teach model. The time intervals for the individual teach functions are, however, considerably different to those of the triangulation sensors. This teach event is described in chapter 7.5.3.

5.4.1 Analog output of the red-light/infrared models (factory setting)

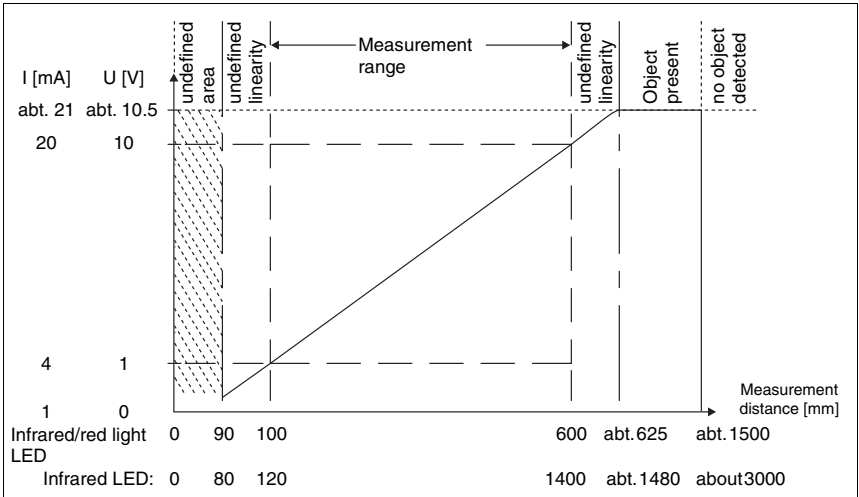

Figure 5.10: Behavior of the analog output on the ODS(R) 96B M/C and M/V (red/infrared light)

5.4.2 Analog output of the triangulation laser model **TRI** (factory setting)

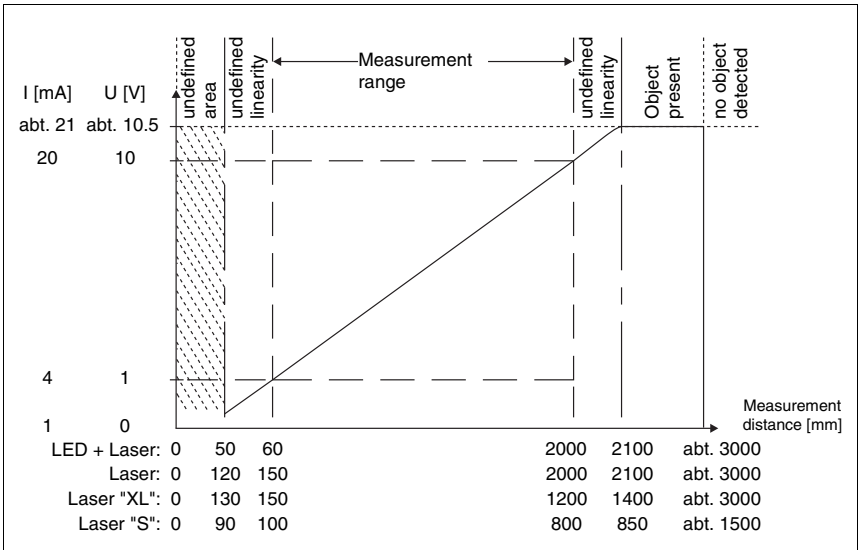

Figure 5.11: Behavior of the analog output on the triangulation laser model

5.4.3 Analog output of the time-of-flight laser model **JLTOF** (factory setting)

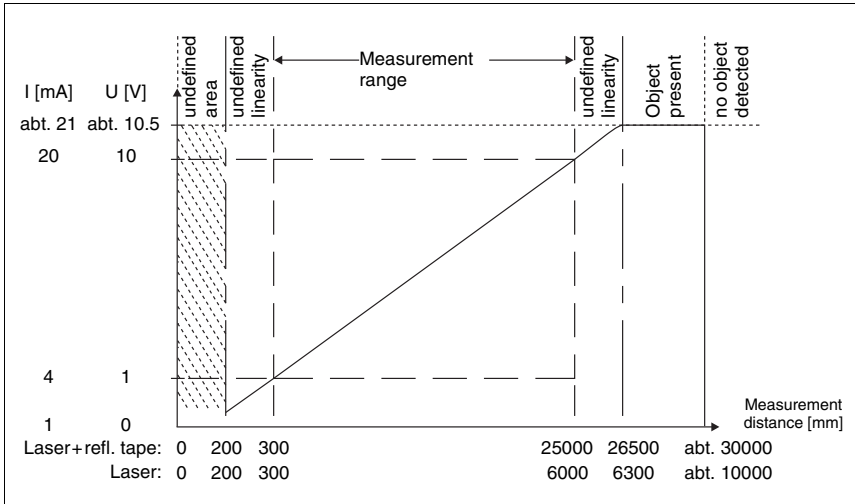

Figure 5.12: Behavior of analog output of the time-of-flight laser model

5.5 ODS... 96B/ODK... 96B M/D with serial output

The ODS... 96B/ODK... 96B M/D... is equipped with one switching output and one serial interface, which is implemented either as an RS 232 interface or as an RS 485 interface. The transmission rate can be set to between 9,600 and 57,600 baud.

Serial transmission is performed with **1 start bit, 8 data bits and 1 stop bit without parity.**

For the transmission of the measurement values, 4 different transmission modes may be configured (see figure 4.7):

- **ASCII measurement value**
(6 bytes)
- **14-bit measurement value**
(2 bytes, ODS 96 compatible)
- **16-bit measurement value**
(3 bytes, ODSL 30 compatible)
- **Remote control operation**

5.5.1 Measurement value output for various transmission types

Object distance	Measurement value output
No evaluable receive signal	0
< Measurement range	distance value (undefined linearity)
Within measurement range	distance value linear
> Measurement range	distance value (undefined linearity)
Device error	0

Measurement value ASCII transmission

Transmission format: **MMMMM<CR>**

- MMMMM** = 5-digit measurement value in mm (for sensors with 1 mm output resolution)
or = 5-digit measurement value in 0.1 mm (for 0.1 mm output resolution)
- <CR>** = ASCII character "Carriage Return" (x0D)

Measurement value = 14-bit (ODS 96 compatible)

Measurement ranges up to 1400mm, output resolution 0.1 mm / Measurement ranges up to 2000mm, output resolution 1 mm

1. Low Byte (bit 0 = 0)



bit 6
bit 5
bit 4
bit 3
bit 2
bit 1
bit 0 (LSB)

2. High Byte (bit 0 = 1)



bit 13 (MSB)
bit 12
bit 11
bit 10
bit 9
bit 8
bit 7

Measurement value = 16-bit (ODSL 30 compatible)

Measurement ranges up to 1400mm, output resolution 0.1 mm / Measurement ranges up to 2000mm, output resolution 1 mm

1. Low Byte (bit 0 = 0, bit 1 = 0)



bit 5
bit 4
bit 3
bit 2
bit 1
bit 0 (LSB)

2. Middle Byte (bit 0 = 1, bit 1 = 0)



bit 11
bit 10
bit 9
bit 8
bit 7
bit 6

3. High Byte (bit 0 = 0, bit 1 = 1)



don't care
don't care
bit 15 (MSB)
bit 14
bit 13
bit 12

Remote control

ASCII transfer of the measurement value on request
4 digits (4 bytes) **or 5 digits** (5 bytes).

Figure 5.13: ODS... 96B/ODK...96B M/D serial transmission formats

5.5.2 Commands for remote control operation

For remote-control operation (Serial -> Com Function -> Remote control), a device address can be set between 0 and 14 (Serial -> Node Address).

In this operating mode, the ODS 96B M/D only responds to commands from the control. The following control commands are available:

4-digit measurement value query (ODS 96 compatible):

	Byte no.									Response time	
	0	1	2	3	4	5	6	7	8		
Command	Sensor address 0x00 through 0x0E	-	-	-	-	-	-	-	-		
Sensor response	"*#" (0x2A)	ASCII address tens	ones	ASCII distance measurement value 1'000's 100's				tens	ones	"#" (0x23)	max. 15ms

5-digit measurement value query (ODSL 30 compatible):

	Byte no.									Response time	
	0	1	2	3	4	5	6	7	8		
Command	"*#" (0x2A)	ASCII address "0...9", "A...D"	"M" (0x4D)	"#" (0x23)	-	-	-	-	-		
Sensor response	"*#" (0x2A)	ASCII address "0...9", "A...D"	ASCII distance measurement value 10'000's 1'000's 100's				tens	ones	State	"#" (0x23)	max. 15ms

Execute the referencing function (only for):

	Byte no.									Response time
	0	1	2	3	4	5	6	7	8	
Command	"*#" (0x2A)	ASCII address "0...9", "A...D"	"R" (0x52)	"#" (0x23)	-	-	-	-	-	
Sensor response	"*#" (0x2A)	ASCII address "0...9", "A...D"	State	"#" (0x23)	-	-	-	-	-	max. 2s

Detailed information on referencing can be found in chapter 7.9.2

Execute preset measurement:

	Byte no.									Response time
	0	1	2	3	4	5	6	7	8	
Command	"*#" (0x2A)	ASCII address "0...9", "A...D"	"P" (0x52)	"#" (0x23)	-	-	-	-	-	
Sensor response	"*#" (0x2A)	ASCII address "0...9", "A...D"	State	"#" (0x23)	-	-	-	-	-	max. 2s

Detailed information on presets/offsets can be found in chapter 7.9.1

Activate sensor:

	Byte no.									Response time
	0	1	2	3	4	5	6	7	8	
Command	"*" (0x2A)	ASCII address "0...9", "A...D"	"A" (0x41)	"#" (0x23)	-	-	-	-	-	
Sensor response	"*" (0x2A)	ASCII address "0...9", "A...D"	State	"#" (0x23)	-	-	-	-	-	max. 15ms

Deactivate sensor:

	Byte no.									Response time
	0	1	2	3	4	5	6	7	8	
Command	"*" (0x2A)	ASCII address "0...9", "A...D"	"D" (0x44)	"#" (0x23)	-	-	-	-	-	
Sensor response	"*" (0x2A)	ASCII address "0...9", "A...D"	State	"#" (0x23)	-	-	-	-	-	max. 15ms

Status byte (bitwise processing):

Bit number	Meaning
7 (MSB)	always = 0 (reserved)
6	1 = other error (e.g. no measurement possible or referencing / preset not successful), 0 = OK
5	always = 1
4	always = 0 (reserved)
3	always = 0 (reserved)
2	1 = sensor deactivated, 0 = sensor activated
1	1 = no signal or signal too low, 0 = signal OK
0 (LSB)	1 = Laser interference, 0 = Laser OK

5.6 ODS... 96B/ODK...96B M/66 with two switching outputs

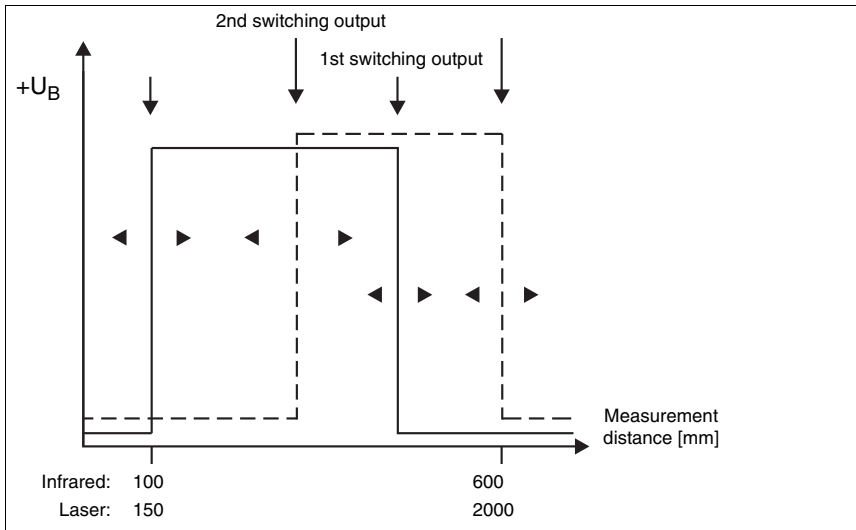

Figure 5.14: Behavior of the switching outputs ODS... 96B/ODK... 96B M/66

The two switching outputs of the ODS... 96B/ODK... 96B M/66 operate independently of each other. Upper and lower switching points as well as hysteresis for both switching outputs can be set separately via the OLED display or the ODS 96B configuration software.

Via the teach input, either the upper or the lower measurement range limit can be taught for both switching outputs or, alternatively, the center of the switching range. An exact description of the teach event can be found in chapter 7.5.

A common teach line is available for both switching outputs, meaning the switching outputs are taught alternately (for slope-control teach-in). The presently taught output is displayed through the simultaneous or alternating flashing of the LEDs (see chapter 7.5).

6 Installation

6.1 Storage, transportation

Unpacking

↳ *Check the packaging for any damage. If damage is found, notify the post office or shipping agent as well as the supplier.*

↳ *Check the delivery contents using your order and the delivery papers:*

- Delivered quantity
- Device variant and model as indicated on the nameplate
- Accessories
- Operating manual

↳ *Save the original packaging for later storage or shipping.*

If you have any questions concerning your shipment, please contact your supplier or your local Leuze electronic sales office.

↳ *Observe the local regulations regarding disposal of packaging material.*

6.2 Mounting

Mounting systems are available which have to be ordered separately at Leuze electronic. The order number can be found in chapter 11.3 and chapter 11.4. Apart from this, the drilled-through holes are suitable for the individual mounting of the ODS, depending on the area in which it is to be used.

Mounting

To avoid errors while the object enters the measurement beam, correct movement direction of the objects has to be observed. The following graphics show instructions on the installation of the optical distance sensors:

Preferred direction of entry movement of the objects when using triangulation sensors

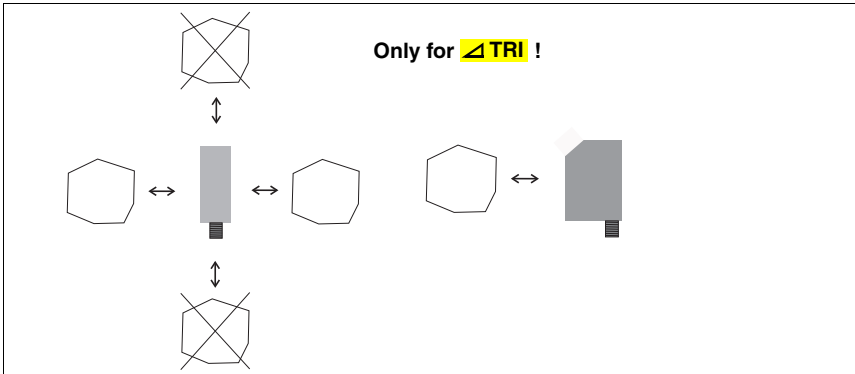

Figure 6.1: Preferred direction of entry movement of the objects when using triangulation sensors

Preferred mounting of triangulation sensors for structured surfaces

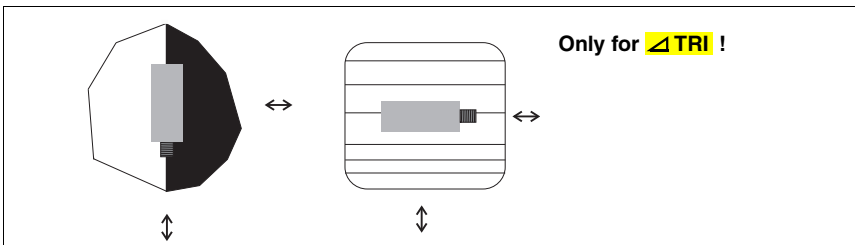

Figure 6.2: Preferred mounting of triangulation sensors for structured surfaces

View through a chase

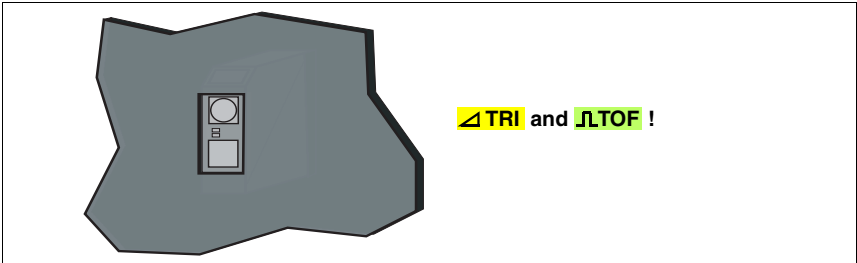

Figure 6.3: View through a chase

If the ODS... 96B/ODK...96B has to be installed behind a cover, the chase has to have at least the size of the optical glass cover. Otherwise, a correct measurement is not possible or can not be guaranteed.

Alignment to measurement objects with reflecting surfaces

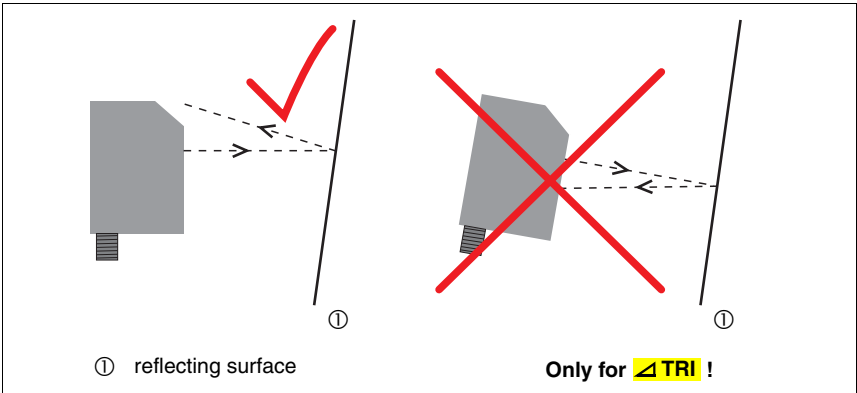

Figure 6.4: Alignment to measurement objects with reflecting surfaces

If the measurement object to be detected has a reflecting surface, a measurement may not be possible depending on the angle in which the light is reflected by the measurement object's surface. The directly reflected part of the transmitted light beam must not be incident on the receiver of the ODS... 96B. Adjust the angle between the sensor and the measurement object such that the sensor can reliably detect the measurement object.

7 Operation

7.1 Indicator and operating elements



Figure 7.1: Indicator and operating elements

The device LEDs display the operating state. For the ODS... 96B/ODK... 96B, the device LEDs have an identical function on the front and back of the distance sensors. During measurement operation, the dot matrix display shows the distance measurement value.

7.1.1 menu operation

The LC display and control buttons of the ODSL 9 are always accessible. The OLED display and key pad of the ODS... 96B/ODK... 96B are protected by a screw-down cover.



Notice

For the ODS... 96B/ODK... 96B, safety class II at a rated voltage of 250 VAC is only ensured with the cover closed.

The ODS is operated using the ▼ and ←| buttons, which are located next to the display.



Notice



The control buttons of the ODSL 9 are not labeled:

- *The **upper key** corresponds to the ▼ button of the ODS... 96B/ODK... 96B.*
- *The **lower key** corresponds to the ←| button of the ODS... 96B/ODK... 96B.*

In menu view, the display has two lines. The ▼ and ←| buttons both have different functions depending on the operating situation. These functions are represented via icons on the right edge of the display – i.e. to the immediate left of the buttons.

The following situations can occur:









Menu navigation

-  ▼ selects the next menu item (Output Q1)
 ↵ switches to the submenu shown with inverted colors (Input)
-  ▼ selects the next menu item (Q1 Upper Sw. Pt.)
 ↵ returns to the next higher menu (←). At the top menu level, the menu can be exited here (← Menu Exit). The number of bars at the left edge indicates the current menu level:





Selecting values or selection parameters for editing

-  ▼ selects the next menu item (↓ -> Q1 Lower Sw. Pt.)
 ↵ selects edit mode for Q1 Upper Sw. Pt.

Editing value parameters

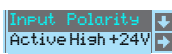
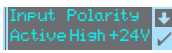
-  ▼ changes the value of the first digit (1)
 ↵ selects the second digit (0) for editing
-  ▼ changes the edit mode;  appears
 ↵ saves the new value (0010)
-  ▼ changes the edit mode;  appears
 ↵ selects the first digit (0) for renewed editing. If an impermissible value was entered, the "new entry" icon initially appears and the checkmark is not available for selection.
-  ▼ changes the edit mode;  or  appears
 ↵ rejects the new value (1016 remains saved)

Editing selection parameters

-  ▼ displays the next option for input polarity (Active High +24V)
 ↵ returns to the input menu and retains Active Low 0V
-  ▼ shows the next option for input polarity (Active Low 0V)
 ↵ selects the new value Active High +24V and displays the confirmation menu:
-  ▼ changes the edit mode;  appears
 ↵ saves the new value (Active High +24V)
-  ▼ changes the edit mode;  appears
 ↵ rejects the new value (Active Low 0V remains saved)

7.1.2 LED indicators

LED	state	Display during sensor operation
green	continuous light	ready
	flashing	interference
	off	no supply voltage
yellow	continuous light	object inside teach-in measurement range
	off	object outside teach-in measurement range

Table 7.1: LED function indicator

During teach-in, the LED indicator deviates from the information shown in Table 7.1 and varies depending on the selected teach mode. Detailed information on this topic can be found in chapter 7.5.

7.2 Switching on

After switching on the supply voltage +U_B and following error-free initialization of the device, the green LED illuminates continuously; the ODS is in measurement mode.



In measurement mode, the current measurement value is displayed in the display. If no object is detected or if the signal is too weak, distance value ∅ mm appears in the display.





Notice

After a warmup time of 20 min., the device has reached the operating temperature required for an optimum measurement.

7.2.1 Reset to factory settings

Press the  button while switching on the device to reset the configuration of the ODS.../ODK... to the state upon delivery from the factory.

Press the  button again to reset all parameters to the factory settings. All settings made previously are permanently lost. Press , and the ODS.../ODK... returns to measurement operation without resetting the parameters.

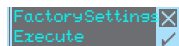

You can also use the menu or the configuration software to reset to factory settings (see chapter 7.4.7).

7.3 Configuration example - lower switching point

To illustrate menu operation, we will explain how to set the lower switching point of switching output Q1 to 100mm as an example

☞ While in measurement mode, press a button in order to activate the menu.



☞ Press ▼; Output Q1 appears in the top menu line

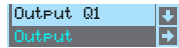

☞ Press ↵ to select Output Q1.



☞ Press ▼ again; Q1 Lower Sw. Pt. appears in the upper menu line.



☞ Press ↵ to set the lower switching point. The first digit of the switching point value is displayed with inverted colors.



☞ Press ▼ as many times as necessary to set the desired value 0.



☞ Accept the value by pressing ↵; repeat the procedure for all other digits.



After pressing ↵ for the 4th time, a appears in the lower right part of the display. The indicates that the next time ↵ is pressed, the set value will be accepted. This behavior of the ↵ button can be changed by repeatedly pressing ▼. A ↻ (re-edit value) and a ✖ (eject value) then appear in succession.

☞ Once you have completed the setting, accept the value by pressing ↵; now, Q1 Lower Sw. Pt. is again displayed with inverted colors, and the new value, saved in non-volatile memory, is displayed.

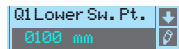

☞ Repeatedly press ▼ until ← appears in the upper menu line.

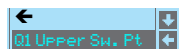

☞ Press ↵ to access the next-higher menu level.

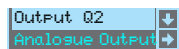

☞ Repeatedly press ▼ until ← Menu Exit appears in the upper menu line.

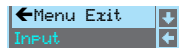

☞ Press ↵ to exit the menu and return to normal measurement operation.



Notice

The selectable or editable values are shown with inverted text colors (black on light-blue background).

If no button is pressed in the configuration menu within 120s, the brightness is then reduced. If no button is pressed in the 60s after that, the device automatically returns to measurement mode.

The device can be protected against unintentional changes to the configuration by activating the password function (see table 7.8 on page 61). The **password** is always set to "165".

7.4 Configuration / menu structure

7.4.1 Input

The function of the "teach in" input (pin 2) is set in the Input menu

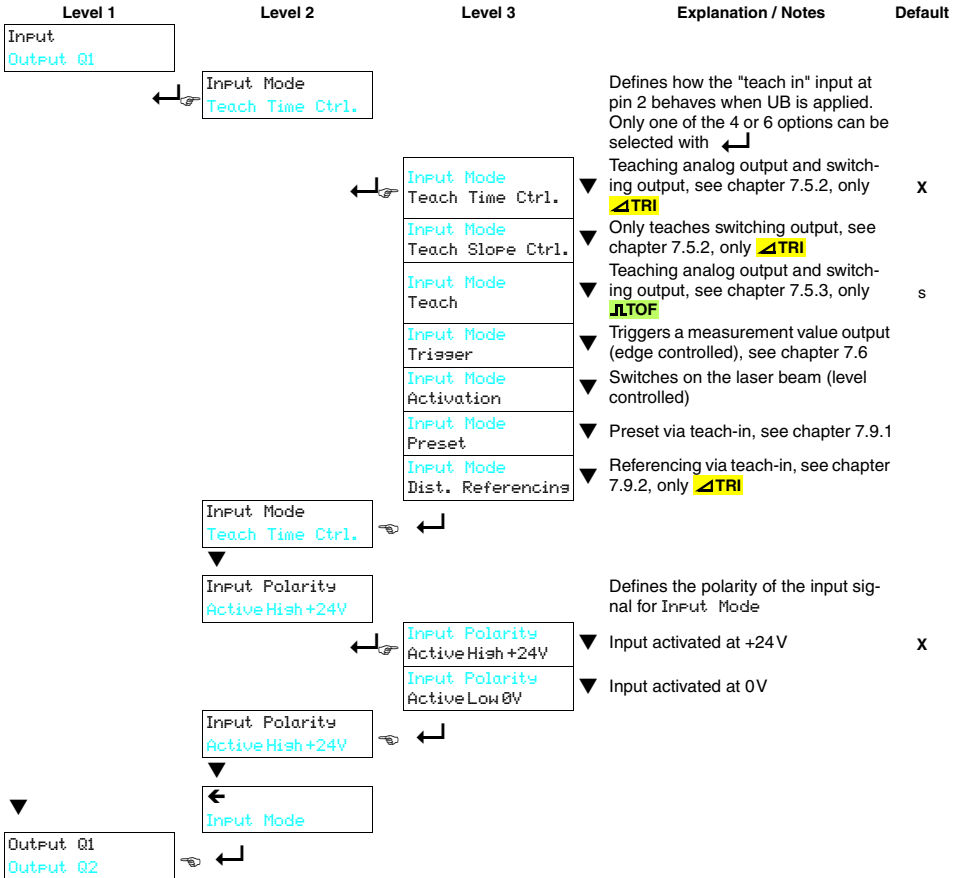

Table 7.2: Input menu

7.4.2 Output Q1

The Output Q1 - menu is available for all sensor models. It is used to set the switching behavior of switching output Q1.

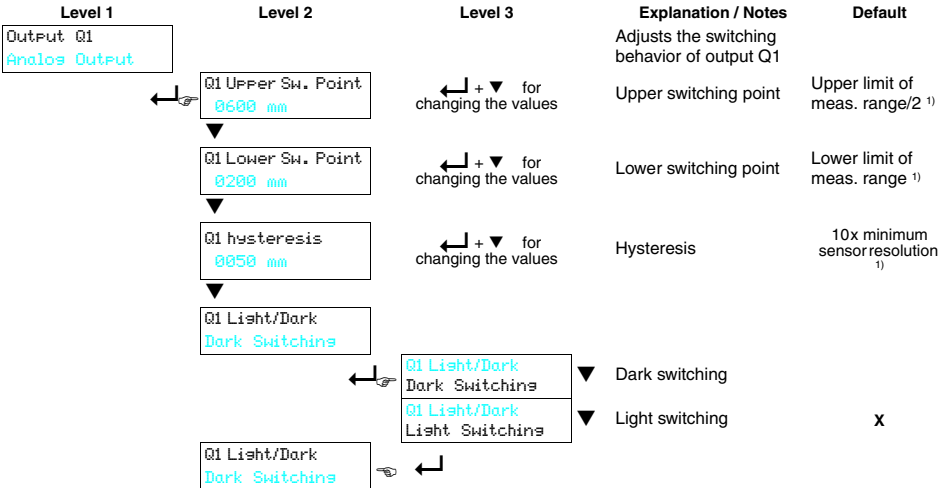

Table 7.3: Menu Output Q1

1) You can determine the values for your sensor using the type key on page 19 and the appropriate data in chapter 10.1. For ODSL 96B sensors with time-of-flight measurement principle, the assured measurement range 300 ... 6,000mm applies (6 ... 90% diffuse reflection).

The adjustable parameters have the following meaning:

- **Light switching:** If an object is located between the upper and lower switching point, the switching output is **active (high)**.
- **Dark switching:** If an object is located between the upper and lower switching point, the switching output is **not active (low)**.
- **Hysteresis:** Expansion of the switching range for switching off. For switching on, the set switching points remain always valid.

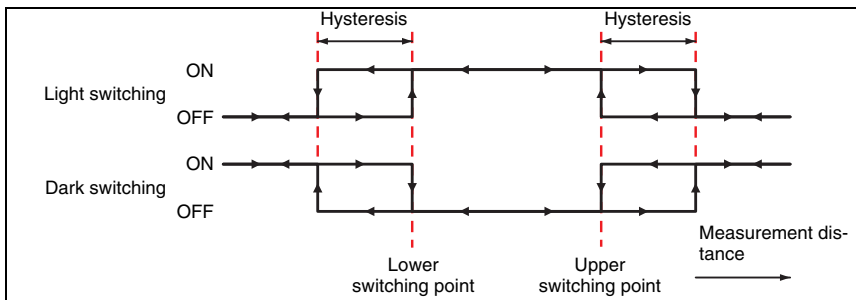

Figure 7.2: Behavior of the switching outputs

7.4.3 Output Q2

Output Q2 - menu only appears if switching output Q2 is present on your ODS. It is used to set the switching behavior of switching output Q2. The adjustable parameters correspond to those of output Q1.

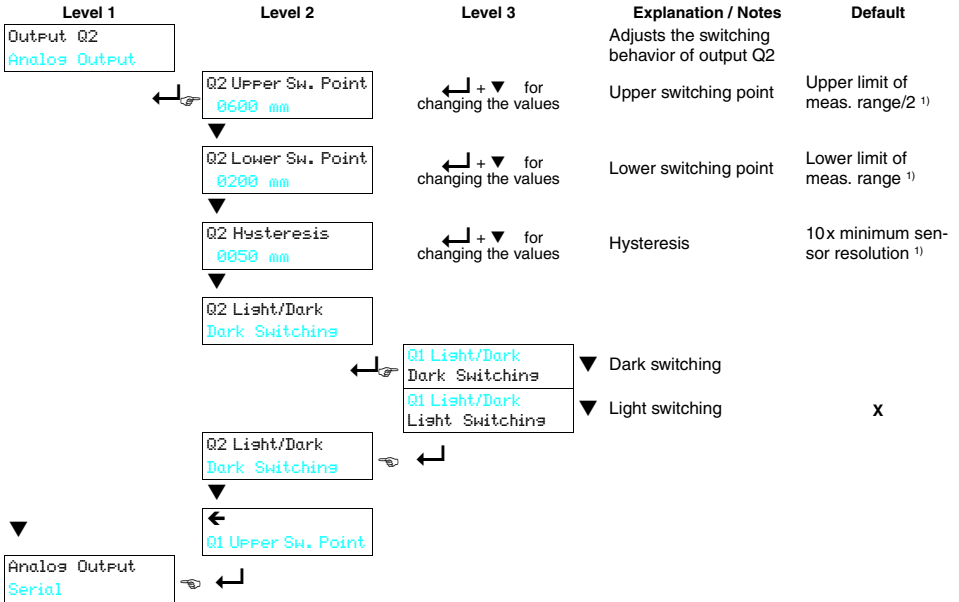

Table 7.4: Menu Output Q2

1) You can determine the values for your sensor using the type key on page 19 and the appropriate data in chapter 10.1. For ODSL 96B sensors with time-of-flight measurement principle, the assured measurement range 300 ... 6,000mm applies (6 ... 90% diffuse reflection).

7.4.4 Analog Output

The Analog Output - menu only appears if your sensor has an analog output. It is used to adjust the characteristic output curve of the analog output.

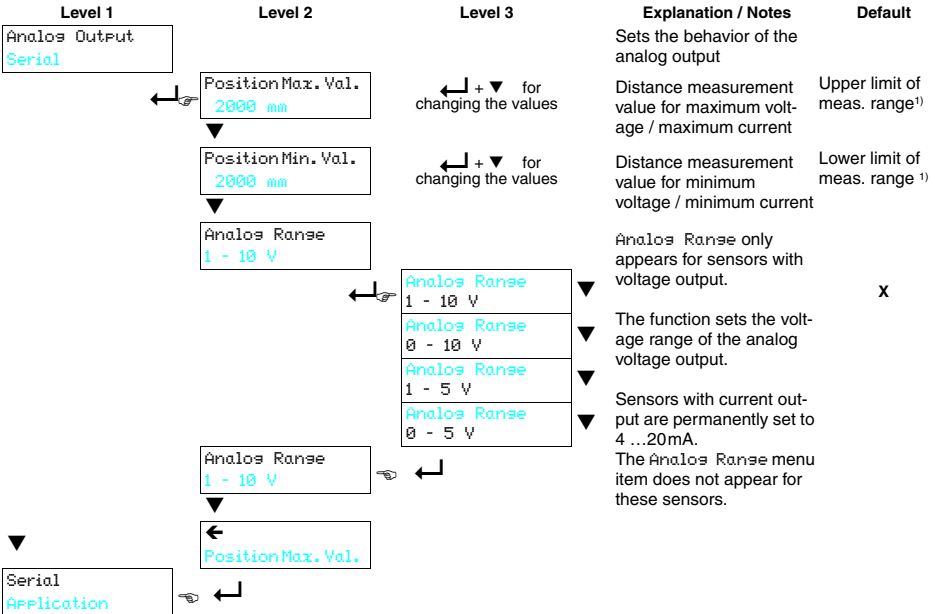

Table 7.5: Analog Output menu

1) You can determine the values for your sensor using the type key on page 19 and the appropriate data in chapter 10.1. For ODSL 96B sensors with time-of-flight measurement principle, the assured measurement range 300 ... 6,000mm applies (6 ... 90% diffuse reflection).

For sensors with voltage output, select the voltage range of the analog output. Then set the distance which corresponds to the lower range limit (0V, 1V or 4 mA) at the analog output and the distance which corresponds to the upper range limit (5V or 10V or 20 mA). This lets you spread the characteristic output curve according to your requirements.

It is also possible to invert the working range of the analog output, i.e., the selected value of the lower range limit is larger than that of the upper range limit. This creates a descending characteristic output curve.



Notice

The adjustable working ranges are dependent on the selected device type and must lie within the sensor's measurement range. The check to determine whether the entered values are plausible and valid is performed after the upper and lower limits are entered. Invalid values cannot be saved. You can either change the entered value (↶) or cancel the entry without saving (⊠).

7.4.5 Serial

The Serial - menu only appears if your sensor has a serial output. It is used to set the transmission type and parameters of the serial output.

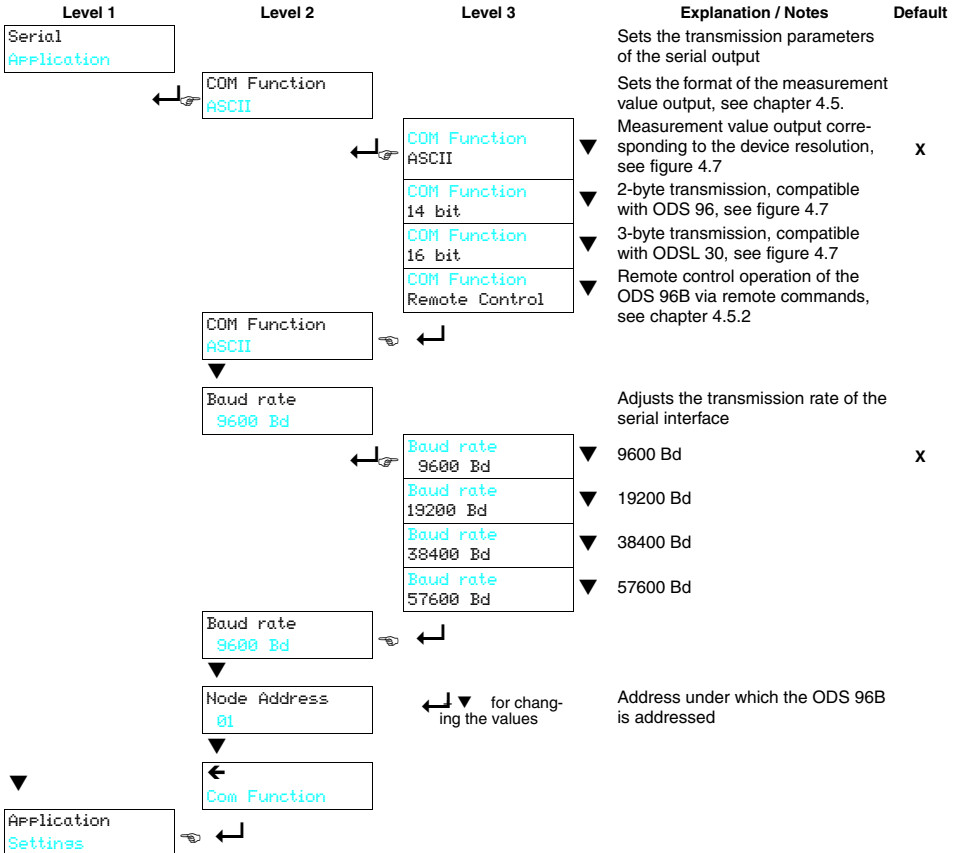

Table 7.6: Serial menu

7.4.6 Application

In the Application - menu, the measurement function of the ODS can be set to the given application.

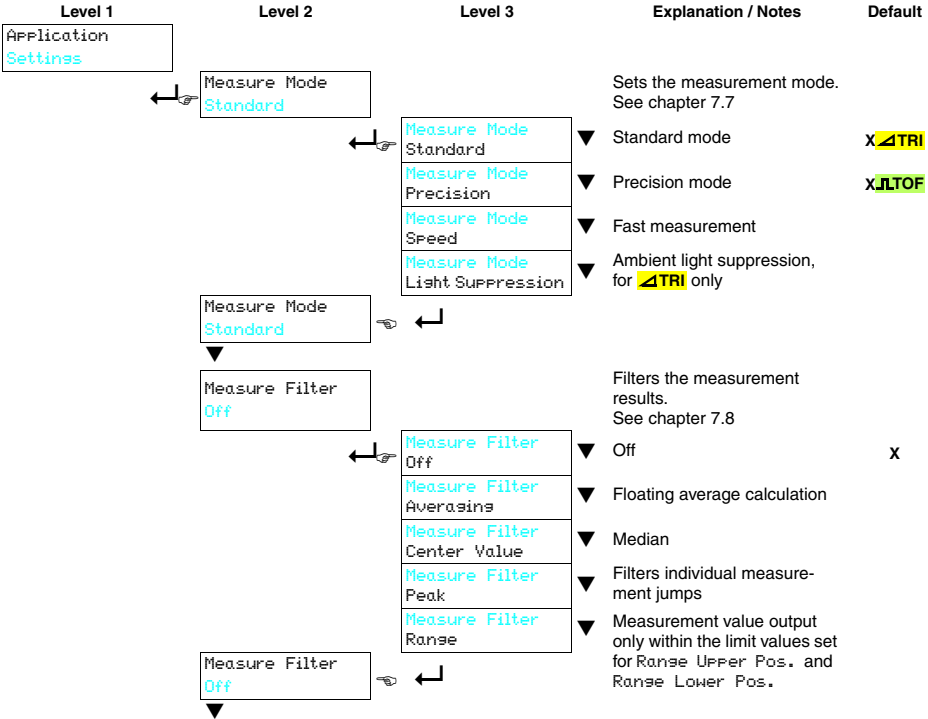

Table 7.7: Application menu

Level 1	Level 2	Level 3	Explanation / Notes	Default
	Measurement. Count 10		Sets the number of measurement values which are read in for the Average and Center Value filters.	
		Measurement. Count 10	For Center Value: selection in steps of 10: 10 measurement values	X
		Measurement. Count 20	20 measurement values	
		Measurement. Count 30	30 measurement values	
		Measurement. Count 40	40 measurement values	
		Measurement. Count 50	50 measurement values	
		Measurement. Count 07	For Averaging: Set from 1 ... 99 for changing the values	01
	Measurement. Count 10			
	Filter Depth Coarse		Sets the filter depth for the Center Value measurement filter. Prevents falsification of the average value by "outliers".	
		Filter Depth Coarse	A small number of extreme values are not taken into account.	X
		Filter Depth Medium	Some extreme values are not taken into account.	
		Filter Depth Fine	A large number of extreme values are not taken into account.	
	Filter Depth Coarse			
	Peak Window Medium		For the Peak measurement filter, sets the minimum deviation of the measurement values from the previous measurement value.	
		Peak Window Medium	Medium change in measurement value	X
		Peak Window Fine	Small change in measurement value	
	Peak Window Medium			
	Range Upper Pos. 2000 mm		Upper limit for the Range measurement filter.	Upper limit of meas. range

Table 7.7: Application menu

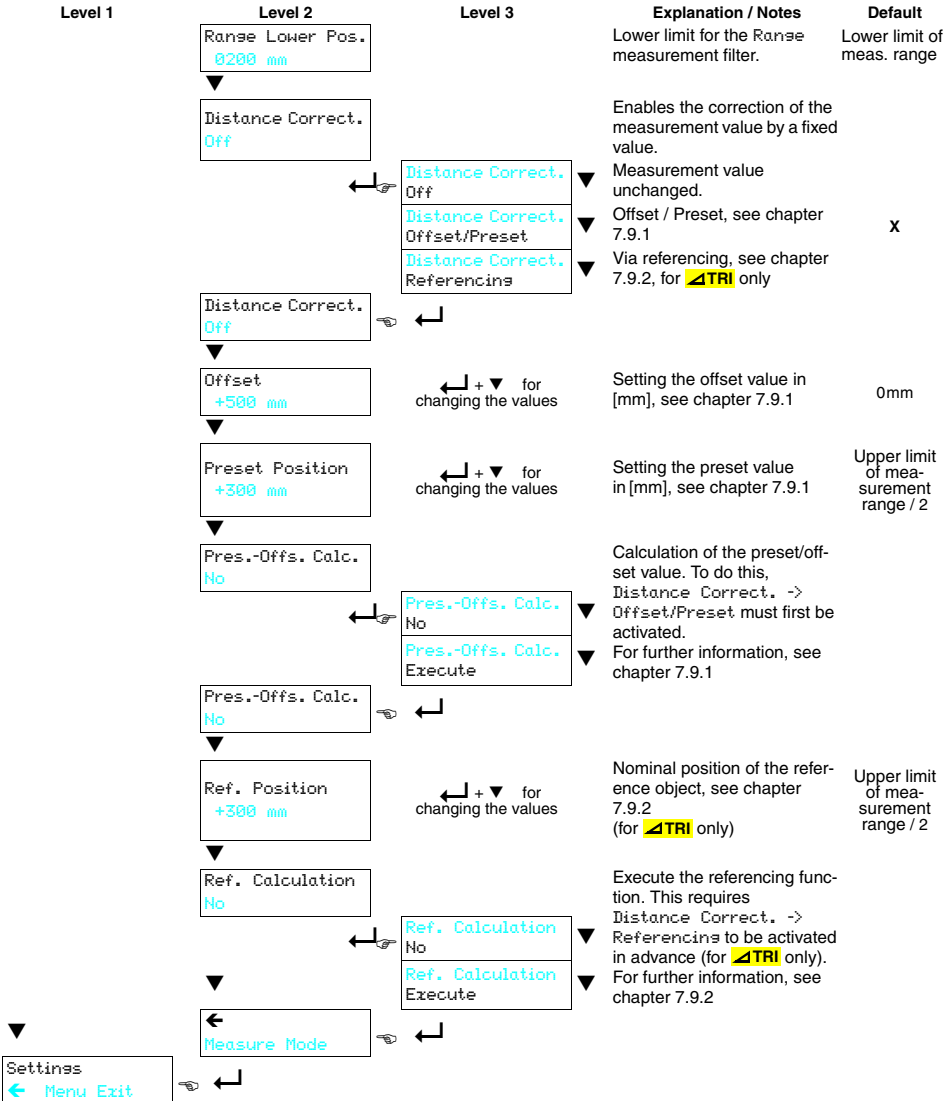

Table 7.7: Application menu

7.4.7 Settings

In the Settings - menu, information on the ODS can be called up and set in the display.

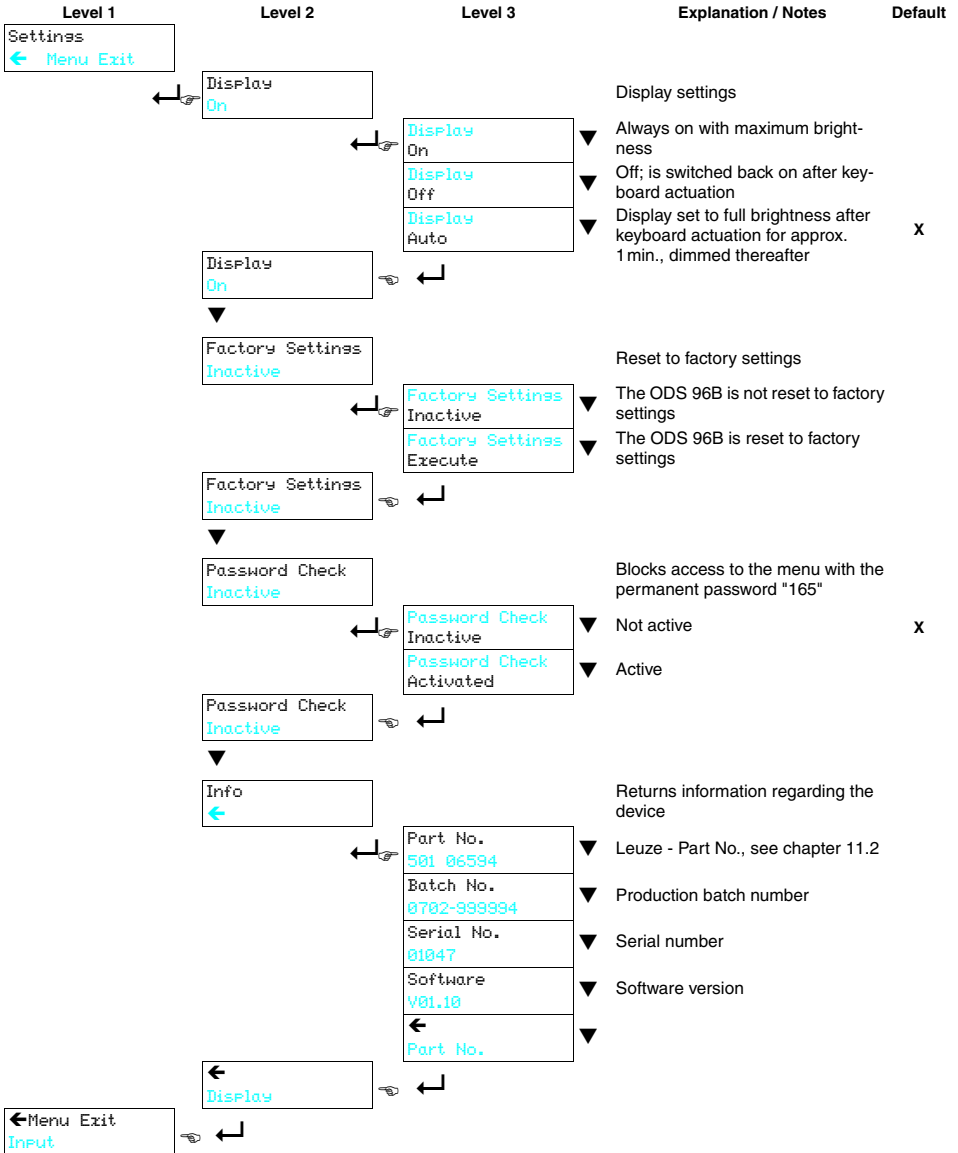

Table 7.8: Settings menu

7.5 Teach-in

Switching points and characteristic output curves can also be set through teach-in without using the software. The following instructions require that you have familiarized yourself with the operation of the ODS using the control buttons and the display.

7.5.1 Setting the teach point

The settings made via the menu or software for the two values **Q1 Upper Sw. Point** and **Q1 Lower Sw. Point** determine the point which is to be taught (applies in an analogous way for Q2). In the following examples, we will consider an ODS 96B with 100 ... 600mm measurement range.

Q1 Lower Sw. Point > 100mm AND Q1 Upper Sw. Point < 600mm

If **both switching points** are set to a value \neq **Lower limit of measurement range** or **Upper limit of measurement range** using the menu or software, the difference between the two values defines a switching range. The teach point is the center of the switching range.

Example:

- Q1 Lower Sw. Point = 400mm
- Q1 Upper Sw. Point = 500mm
- yields a switching range of 100mm

The teach point lies in the middle of the switching range. If a distance of e.g. 300mm is now taught, the Q1 switches on at 250mm and back off at 350mm.

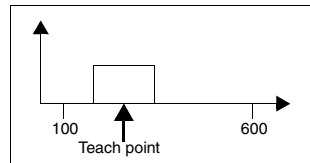

Q1 Lower Sw. Point = 100mm AND Q1 Upper Sw. Point < 600mm

If the **lower switching point** is set to the **Lower limit of measurement range** using the menu or software, the **upper switching point** is taught.

Example:

- Q1 Lower Sw. Point = 100mm
- Q1 Upper Sw. Point = 357mm

The teach point defines the upper switching point. If a distance of e.g. 300mm is now taught, the Q1 switches on at 100mm and back off at 300mm.

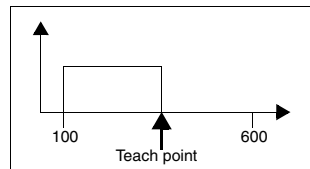

Q1 Lower Sw. Point > 100mm AND Q1 Upper Sw. Point = 600mm

If the **upper switching point** is set to the **Upper limit of measurement range** using the menu or software, the **lower switching point** is taught.

Example:

- Q1 Lower Sw. Point = 225mm
- Q1 Upper Sw. Point = 600mm

The teach point defines the lower switching point. If a distance of e.g. 300mm is now taught, the Q1 switches on at 300mm and back off at 600mm.

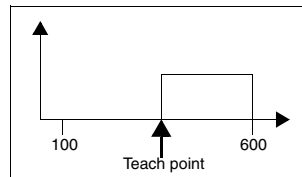

7.5.2 Teach-in for triangulation sensors

Teach-in of the switching outputs (Slope Control)

In this teach mode, the teach event is performed in the same way as with the ODS 96.

- ↳ On the OLED display, activate menu item:
Input -> Input Mode -> Teach slope control
- ↳ Position the measured object at the desired distance.
- ↳ Activate the "**teach in**" input (pin 2) for at least 100 ms (by applying $+U_B$ or GND, depending on the setting for Input Polarity, see chapter 7.4.1).

The yellow and green LEDs flash **simultaneously** during this process.

- ↳ After that, connect the teach input to GND.

You have now taught in the 1st switching output.

If your device has another switching output which you would like to teach:

- ↳ Position the measured object at the second desired distance.
- ↳ Reactivate the "**teach in**" input (pin 2) for $\geq 2s$.

The yellow and green LEDs flash **alternately** during this process.

- ↳ After that, connect the teach input to GND.

You have now taught in the 2nd switching output.

The taught switching points are dependent on the settings for the upper and lower switching point, see "Setting the teach point" on page 62.

Teach-in of the switching outputs/characteristic output curve (time control)

In addition to the edge controlled teach-in of the switching output, it is also possible to perform a level-controlled teach-in of switching output and output characteristic curve via the teach line for ODS... 96B devices with analog output. The following steps are necessary for the level-controlled teach-in:

If you have changed the factory setting for teaching under Input Mode:

- ↳ On the OLED display, activate menu item:
Input -> Input Mode -> Teach time control
- ↳ Position the measured object at the desired distance.
- ↳ Activate the "**teach in**" input (pin 2) (by applying $+U_B$ or GND, depending on the setting for Input Polarity, see chapter 7.4.1).

The duration of the activation of the teach input determines the teach step according to the table shown below. The teach event is indicated by the flashing of the LEDs and on the display.

Teach function	Duration of teach signal	LED green	LED yellow
Switching output Q1 Teach point, see chapter 7.5.1	2 ... 4 s	flash synchronously	
Distance value for start of measurement range = 1 V / 4 mA at analog output (pin 5)	4 ... 6 s	continuous light	flashing
Distance value for end of measurement range = 10 V / 20 mA at analog output (pin 5)	6 ... 8 s	flashing	continuous light

Table 7.9: LED indicator while teaching the characteristic output curve (Time Control)

At the end of the given teach event:

 *Reconnect the teach input to GND.*

A successful teach event is signaled by the end of the flashing of the LEDs. The menu entries can be used to check that the teach values are properly accepted and to make any changes.



Notice

If the measurement range start is taught to a distance greater than the measurement range end, a declining characteristic output curve is automatically set.

Second switching output for Time Control

Sensors with two switching outputs can also be taught in Time Control mode. The LEDs indicate the respective teach step as follows:

- green and yellow LEDs flash simultaneously: Teach switching output Q1
- green LED is on continuously, yellow LED flashes: Teach switching output Q2

Error messages

Continuously flashing LEDs indicate an unsuccessful teach event. The sensor remains ready for operation and continues to function with the old values.

Remedy:

- Repeat teach event **or**
- Activate teach input for more than 8 s **or**
- Disconnect sensor from voltage to restore the old values.

7.5.3 Teach-in for time-of-flight sensors **JLTOF**

Teach-in of the switching outputs/characteristic output curve

The following steps are required for time-controlled teach-in of TOF sensors:

If you have changed the factory setting for teaching under `Input Mode`:

- ↳ On the display, activate menu item:
`Input -> Input Mode -> Teach`
- ↳ Position the measured object at the desired distance.
- ↳ Activate the **"teach in"** input (pin 2) (by applying $+U_B$ or GND , depending on the setting for `Input Polarity`, see chapter 7.4.1).

The duration of the activation of the teach input determines the teach step according to the table shown below.

Teach function	Duration T of teach signal
Switching output Q1 Teach point, see chapter 7.5.1	20 ... 80ms
Switching output Q2 (devices with 2 switching outputs) Teach point, see chapter 7.5.1	120 ... 180ms
Distance value for start of measurement range = 1V or 4mA at analog output (pin 5)	220 ... 280ms
Distance value for end of measurement range = 10V or 20mA at analog output (pin 5)	320 ... 380ms

Table 7.10: Teach function in correspondence with the duration of the teach signal

The menu entries can be used to check that the teach values are properly accepted and to make any changes.

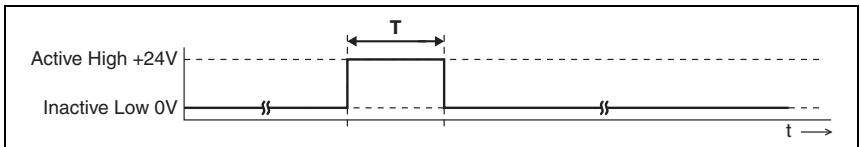

Figure 7.3: Teach signal curve for time-of-flight sensors



Notice

If the inactive level is permanently applied to the teach input, the teach input is locked.
 If the menu is set to `Input -> Input Mode -> Input Polarity -> Active Low +0V`, inverted input signals are used for teaching.

7.6 Trigger

No continuous measurement occurs while in Input Mode -> Trigger.

An ascending edge at the "teach in" input (pin 2) triggers a single measurement; the measurement value is present at the output until the next trigger event. This applies for ODS-models with analog output and serial output.

In this way it is possible to precisely perform individual measurements for the trigger signal in combination with a photoelectric sensor even in dynamic situations.

7.7 Measurement modes

In the Application menu, you can set 3 or 4 different measurement modes. The effect on the measurement behavior of the ODS depends on the device:

Triangulation sensors

- Standard: Standard setting
- Precision: High accuracy, approx. 95% slower
- Speed: Fast measurement, approx. 30% faster
- Light Suppression: Higher insensitivity towards ambient light

The following table provides an overview of the effects of the individual parameters on the measurement function.

	Accuracy	Measurement time / updating	Ambient light	Varying diffuse reflection
Standard	+	+	+	+
Precision	++	--	+	+
Speed	-	++	+	+
Light Suppression	+	--	++	0

Table 7.11: Effect of the measurement modes for triangulation sensors

Time-of-flight sensors

- Standard: Standard setting
- Precision: Factory setting, accuracy twice as high compared to standard, about 5 times slower
- Speed: Accuracy three times lower compared to standard, about 8 times faster

The following table provides an overview of the effects of the individual parameters on the measurement function.

	Accuracy	Measurement time	Measurement value updating	Ambient light
Standard	+	10ms	+	++
Precision	++	50ms	--	++
Speed	-	1.2ms	++	++

Table 7.12: Effects of the measurement modes for time-of-flight sensors

7.8 Measurement filters

In the **Application** menu, you can set 5 different measurement filters. This affects the measurement behavior of the ODS as follows:

- **Off:** No filtering of the measurement values
- **Averaging:** A sliding average is calculated and output from the last 2 ... 99 measurement values (set the number with **Measurement Count**). If the measurement value changes abruptly, the output value moves linearly over the course of n measurements from the old measurement value to the new measurement value. Thus, the time for measurement value updating is not affected by the number of measurements; the response time for distance changes becomes slower.
- **Center Value:** Filter out extreme values - the average value is calculated from every 10 ... 50 single measurements. The number of single measurements to be used is selected with **Measurement Count** (10, 20, 30, 40 or 50). The setting made under **Filter Depth** specifies whether only the most extreme (**Coarse**), medium (**Medium**) or minor deviations (**Fine**) should be filtered out.
- **Peak:** Filters out jumps in measurement values. Measurement values are only passed on if the difference to the last measurement value is not too large. Following a change in distance, the values are not output until the distance value has quieted back down. The setting under **Peak Window** is used to specify whether only medium (**Medium**) measurement jumps are to be filtered out or if smaller (**Fine**) jumps are to be filtered as well.
- **Range:** The measurement value output is limited to the range which is defined with **Range Lower Pos.** and **Range Upper Pos.**, located down further in the menu. Example with **Range Lower Pos.** = 300mm and **Range Upper Pos.** = 400mm:
 - for distances < 300mm, 300mm is output as measurement value
 - between 300mm and 400mm, the actual measurement value is output
 - for distances > 400mm, 400mm is output as measurement value.



Notice

For Center Value, the time for measurement value updating increases considerably!

The following table provides an overview of the effects of the individual parameters on the measurement function.

	Measurement time updating	Response time to small changes in distance	Response time to large changes in distance	Filtering individual incorrect measurements	Filtering cumulative incorrect measurements
Off	+	+	+	--	--
Averaging	+	-	-	0	-
Center Value	--	-	-	++	+
Peak	0	+	0	+	-
Range	+	+	-	0	0

Table 7.13: Effects of Measure Filter

7.9 Distance calibration

Using the `Distance Correct.` menu item, it is possible to influence the measured distance value. The following table provides an overview of the available options.



Notice

Offset and Preset are used for correcting the measurement value by a fixed amount. Referencing, on the other hand, increases the accuracy of measurements in the distance range near the taught reference distance. To obtain the most exact measurement accuracy possible, referencing should be performed as close to the measurement as possible. Execution of the referencing function via the teach input is ideally suited for this.

7.9.1 Preset or Offset

Deviations which occur while mounting the ODS can be compensated for by the **Offset** or **Preset** parameter:

- For **Offset**, a fixed value and sign are specified.
- For **Preset**, a nominal measurement value is specified; a measurement is then performed using an object located at the desired nominal distance. The **Offset** parameter mentioned above is changed as a result of this measurement.



Notice

If calculation of the offset results in negative measurement values, zero is output at the interface and on the display.

Setting the offset

Configuration is performed using the key pad and display:

↳ *Select:*

Application -> Distance Correct. -> Offset/Preset

↳ *Then enter the offset value:*

Application -> Offset

The set offset value is added to the measured distance value of the sensor.

Example:

Measurement value of the ODS 96B: 1500mm

Input: Offset: -100mm

Output on the display and at the interface: 1400mm

Setting the preset

Configuration is performed using the key pad and display:

↳ *Select:*

Application -> Distance Correct. -> Offset/Preset

↳ *Then enter the preset value:*

Application -> Preset Position

↳ *Position an object at the desired preset distance.*

↳ *Perform a preset measurement:*

Application -> Pres.-Offs. Calc. -> Execute

The offset value is automatically calculated from the measurement value and nominal measurement value (preset value) and entered as the offset in the configuration.

Example:

Input: Preset value: 1400mm,

Object dist. 1300mm in front of ODSL 96B: Preset Calculation ...active, trigger measurement with Execute, an offset of +100mm is automatically stored

Object distance 1300mm: Output on display and at interface: 1400mm

Object distance 1400mm: Output on display and at interface: 1500mm

Deactivating Offset / Preset

The offset correction can be deactivated by setting the offset value to zero or by selecting a different mode under Distance Correct. In the latter case, when the "Offset/Preset" mode is reselected, the most recently set offset and preset values are again available.

7.9.2 Referencing for triangulation sensors

ODS triangulation sensors have a referencing function for the internal calibration of the sensor.



Notice

The referencing function is not available for time-of-flight sensors ().

By carrying out the integrated reference measurement function before a measurement, the sensor's accuracy can be improved by having the ODS also measure the environmental conditions during reference measurement. The corrective value determined here is used if referencing is activated.

↳ Select:

Application -> Distance Correct. -> Referencing

↳ Then enter the reference value:

Application -> Ref. Position

↳ Before referencing, position an object in front of the ODS at the desired reference distance.

↳ Perform a reference operation:

- **Using a command:** In remote control mode, see chapter 4.5.2
- **Using teach-in:** To do this, use the menu or software to activate the Input -> Input Mode -> Dist. Referencing function. Then **each time** the teach input (pin 2) is activated, referencing is performed.
- **Using a menu command:** Use the menu or software to set Application -> Distance Correct. -> Referencing, and then execute the Application -> Ref. Calculation -> Execute menu command. This starts a **one-time** referencing operation.

The referencing correction is deactivated by selecting a different mode under Distance Correct. (Off or Offset/Preset). When the Referencing mode is again selected, the most recently set reference distance is again available. If re-referencing is not performed, the old corrective values may result in incorrect measurement values.



Notice

In particular, the referencing function should be performed for changing environmental conditions. In addition, you should perform referencing prior to all measurements which have elevated accuracy requirements.

While executing the referencing function (duration approx. 2s), no measurements are possible; the reference object must remain still during this period!



Notice

For the ODS... 9/96B, referencing is a selective calibration on a target located at a specified reference distance. The entire measurement system is not referenced as it is with the ODSL 30.

8 Software

General description

The ODS 96B configuration software can be used both for the direct configuration of data with the distance sensor connected, as well as "offline" without a sensor connected for the generation of device configurations.

If no distance sensor is connected, a dialogue is displayed after starting the program in which you have to choose the device model (see chapter 8.3). After the offline generation of a configuration, this configuration can be transmitted to the sensor after connection to the PC has been established.

You can download the software on the Internet from www.leuze.de.

8.1 Connecting to a PC

The distance sensor is connected to a PC via the UPG 10 programming terminal. The terminal is simply inserted between the sensor and the connection cable. The UPG 10 is connected to the PC via the serial interface cable that ships with the UPG 10.

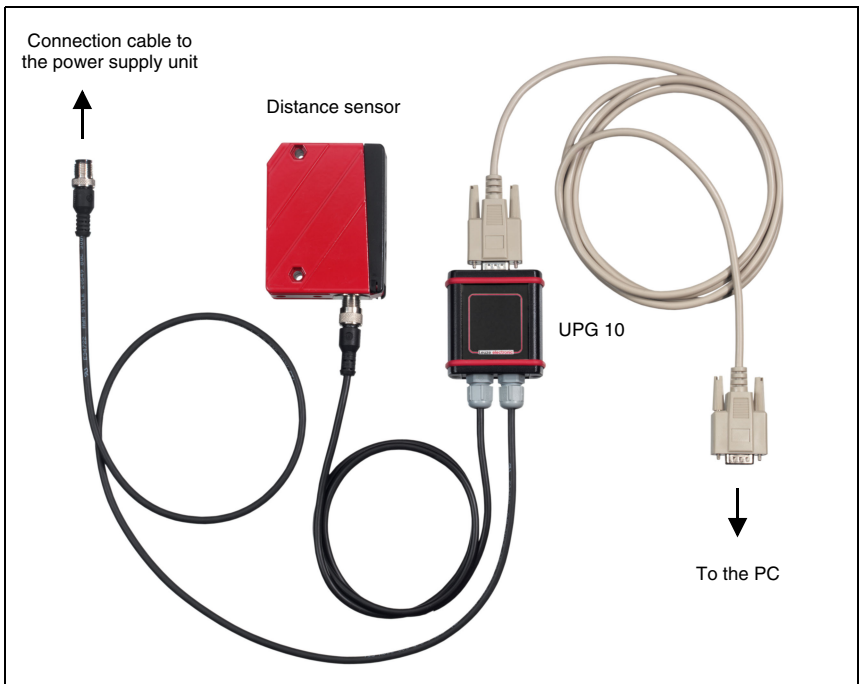

Figure 8.1: Connecting the distance sensor via the UPG 10 programming terminal

8.2 Installing the configuration software

Requirements for the installation of the ODS 96B configuration software:

- Pentium® or faster Intel® processor (or compatible models, e.g. AMD®)
- At least 64 MB free main memory (RAM)
- Hard disk with at least 30 MB free memory
- RS 232 interface for sensor configuration
- Microsoft® Windows 98/NT/2000/XP

Starting the installation file

↳ Choose **Start** → **Run**. Insert drive and name of the installation file (e.g.: d:\setup.exe) and hit **OK**.

↳ In the following window, define the path for the installation directory and confirm with **End**.

8.3 Starting the program

After successful installation and restart of the computer, the configuration software is ready to use.

↳ Select the ODS 96B configuration software icon from the program group.

If no sensor is connected, the software boots in demo mode.

8.4 Main window ODS 96B configuration software

After selecting a device type and confirming with OK, the following window appears:

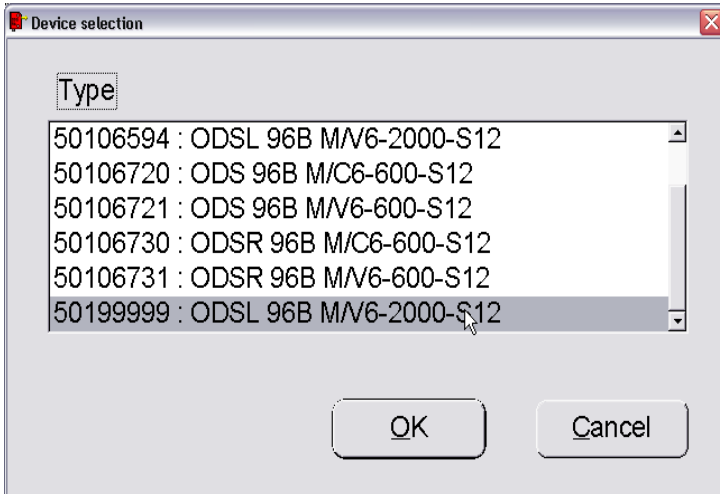

Figure 8.2: ODS 96B configuration software - main window

The **menu bar** of the ODS 96B configuration software offers the following functions

- **File** -> Exit program
- **Options** -> Language and interface selection. German and English are the available languages. Under Interface, you must select the COM port to which the distance sensor is connected. The necessary communication parameters are automatically set for the interface.

Additional functions can be executed in the **main window**:

- **Start measurement** and **Stop measurement** are used to graphically represent the measurement values in the main window.

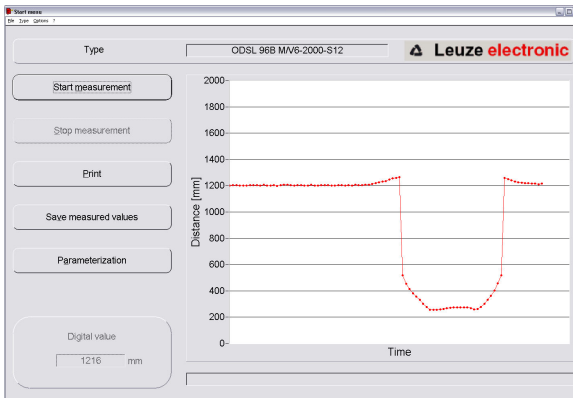

Figure 8.3:ODS 96B configuration software - measurement

- Use **Print** to send the currently detected measurement curve to the default Windows printer.
- **Save measured values** saves the current measurement values in a text file
- **Parameterization** opens the configuration window, see next chapter

8.5 Configuration window

The individual menu items are self-explanatory and correspond to the menus of the display in the distance sensor. Explanations of the possible settings can be found in chapter "Configuration / menu structure" on page 53.

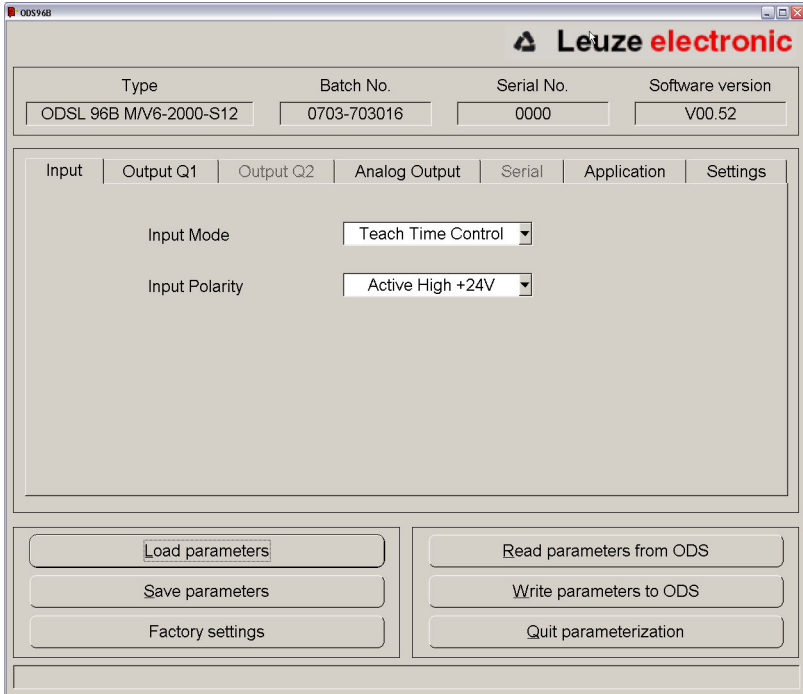

Figure 8.4: ODS 96B configuration software - configuration window

8.5.1 Description of the command buttons

The command buttons at the bottom of the screen have the following functions:

Load parameters

Loads a saved configuration from the hard disk.

Save parameters

Saves a created configuration on the hard disk.

Factory settings

Resets the connected distance sensor to factory settings.

Read parameters from ODS

Reads and displays the configuration of the connected ODS 96B.

Write parameters to ODS

Saves the current configuration in the non-volatile parameter memory of the ODS 96B

Quit parameterization

Ends the program

**Notice**

Leuze electronic can only deliver distance sensors with default settings. You as customer are responsible for correct storage of your changed data sets. Back-up your device configuration on data carriers.

9 Specifications ODSL 9

9.1 Optical data

	ODSL 9/...-450-S12 ODSL 9/...-450-S12 Laser	ODSL 9/...-100-S12 ODSL 9/...-100-S12 Laser
Optical data		
Measurement ranges ¹⁾	50 ... 450mm	50 ... 100mm
Resolution	0.1 mm	0.01 mm
Light source	laser	laser
Wavelength	655 nm (red light)	655 nm (red light)
Light spot diameter	divergent, 1 x 1 mm ² at 450mm distance	divergent, 1 x 1 mm ² at 100mm distance
Error limits ²⁾		
Absolute measurement accuracy ¹⁾	± 1%	± 0.5%
Repeatability ³⁾	± 0.5%	± 0.25%
b/w detection thresholds (6%/90%)	£ 0.5%	£ 0.5%
Temperature compensation	yes ⁴⁾	yes ⁴⁾
Timing		
Measurement time ¹⁾	2ms	2ms
Response time	£ 6 ms	£ 6 ms
Delay before start-up	£ 300ms	£ 300ms

- 1) Luminosity coefficient 6 ... 90%, complete measurement range, "Standard" operating mode, at 20°C medium range U_B, measurement object ³ 50x50mm²
- 2) After an operating time of 20min., the device has reached the operating temperature required for an optimal measurement.
- 3) Same object, identical environmental conditions, measurement object ³ 50x50mm²
- 4) Typ. ± 0.02%/K

9.2 Electrical data, installation data

	ODSL 9/ C...	ODSL 9/ V...	ODSL 9/ D...	ODSL 9/ (C)66...
Electrical data				
Operating voltage U_B	18 ... 30VDC (incl. residual ripple)			
Residual ripple	£ 15% of U_B			
Bias current	£180mA			
Switching outputs ¹⁾	1 push/pull output, teachable			2 push/pull outputs, partially teachable
Signal voltage high/low	³ ($U_B - 2V$) / £ 2V			
Analog output	current 4 ... 20mA, R_L £ 500Ohm	voltage 1 ... 10V ²⁾ , R_L ³ 2kOhm		
Output current	max. 100mA for each push/pull output			
Serial interface RS 232			9600 baud (factory setting), baud rate configurable	
Transmission protocol			2/3 byte transmission, const. data flow, see chapter 4.5	
Mechanical data				
Housing	plastic			
Optics cover	glass			
Weight	approx. 50g			
Connection type	M12 connector, 5-pin			
Environmental data				
Ambient temp. (operation/storage)	-20 ... +50°C / -30 ... +70°C			
Ambient light limit	³ 5kLux			
Protective circuit ³⁾	1,2,3			
VDE safety class ⁴⁾	II, all-insulated			
Protection class	IP 67			
Standards applied	IEC 60947-5-2			

- 1) The push-pull switching outputs must not be connected in parallel
- 2) Factory setting, 1 ... 10V / 0 ... 10V / 1 ... 5V / 0 ... 5V adjustable
- 3) 1=transient protection, 2=polarity reversal protection, 3=short-circuit protection for all outputs
- 4) Rating voltage 50 V AC with closed cover

9.3 Dimensioned and Connection Drawings

ODSL 9 laser models

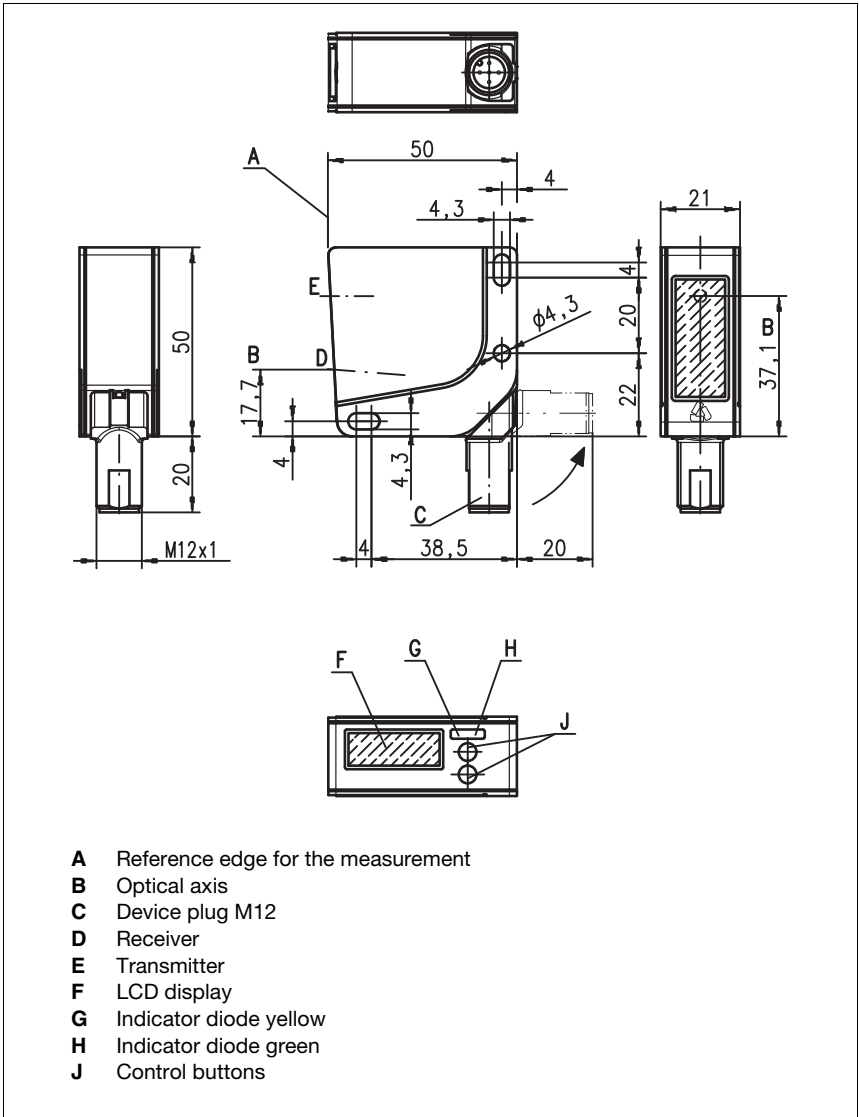

Figure 9.1: Dimensioned drawing ODSL 9...

ODSL 9 /C6 with analog current output

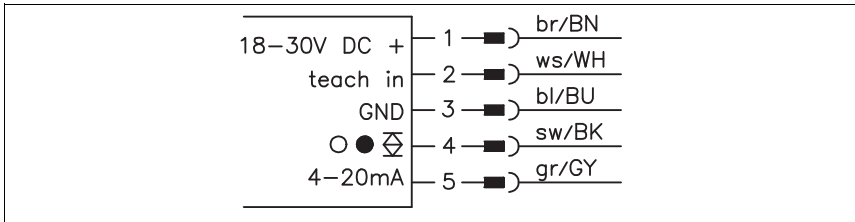

Figure 9.2: Electrical connection ODSL 9/C6...

ODSL 9 /C66 with analog current output and 2 switching outputs

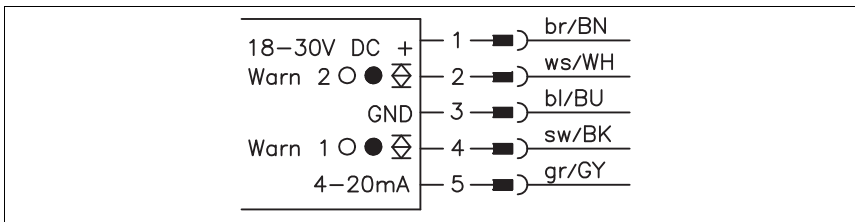

Figure 9.3: Electrical connection ODSL 9/C66...

ODSL 9/V6 with analog voltage output

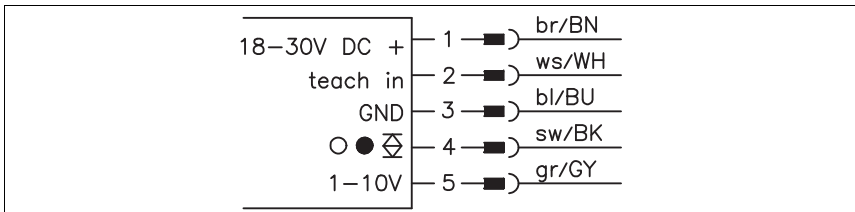

Figure 9.4: Electrical connection ODSL 9/V6...

ODSL 9/D26 with serial RS 232 output

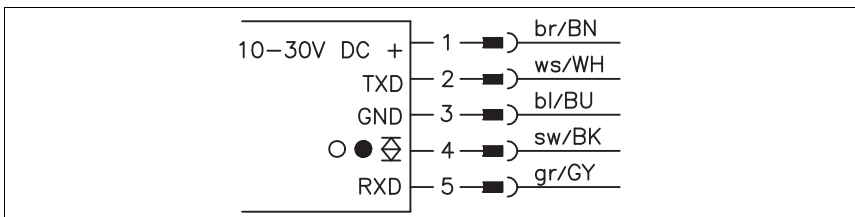

Figure 9.5: Electrical connection ODSL 9/D26...

ODSL 9/D36 with serial RS 485 output

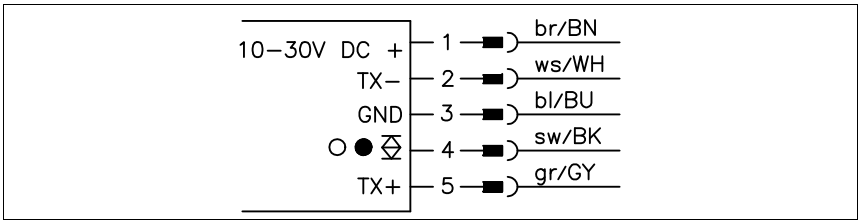

Figure 9.6: Electrical connection ODSL 9/D36...

ODSL 9/66 with 2 teachable push/pull outputs

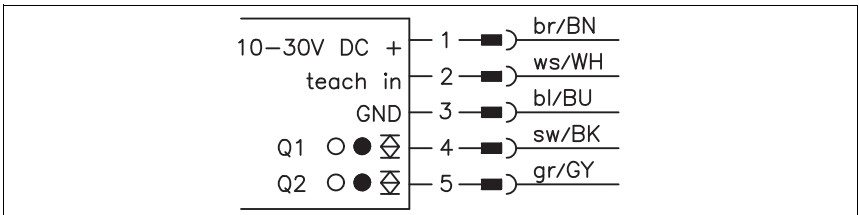

Figure 9.7: Electrical connection ODSL 9/66...

10 Specifications ODS... 96B/ODK... 96B

10.1 Optical data: triangulation sensors

	ODS(R) 96B M/C, M/V, M/D red light / infrared light	ODSL(R) 96B M/C, M/V, M/D laser
Optical data		
Measurement ranges ¹⁾	100 ... 600mm 120 ... 1400mm	60 ... 2000mm 150 ... 2000mm 150 ... 800mm ("S") 150 ... 1200mm ("XL")
Resolution	0.1 ... 0.5mm (600mm) 0.1 ... 1mm (1400mm)	1 ... 3mm 0.1 ... 0.5mm ("S") 0.1 ... 1.5mm ("XL")
Light source	LED (modulated light)	laser (modulated light)
Wavelength	880nm (infrared) 635nm (red light)	655nm
Light spot diameter	approx. 15mm at 600mm distance	divergent min. 2mm x 6mm at 2000mm distance divergent, 1mm x 1mm at 800mm distance ("S") divergent, 15mm x 4mm at 800mm distance ("XL")
Error limits ²⁾		
Absolute measurement accuracy ¹⁾	± 1.5%	± 1.5%
Repeatability ³⁾	± 0.5%	± 0.5%
b/w detection thresholds (6%/90%)	£ 1%	£ 1%
Temperature compensation	yes ⁴⁾	yes ⁴⁾
Timing		
Measurement time	1 ... 5ms ¹⁾	1 ... 5ms ¹⁾
Response time	£ 15 ms	£ 15 ms
Delay before start-up	£ 300ms	£ 300ms

1) Luminosity coefficient 6 ... 90%, complete measurement range, "Standard" operating mode, at 20°C medium range U_B , measurement object ³ 50x50mm²

2) After an operating time of 20min., the device has reached the operating temperature required for an optimal measurement.

3) Same object, measured object ³ 50x50mm²

4) Typ. ± 0.02%/K

10.2 Optical data: time-of-flight sensors JLTOF

	ODSL 96B M/C, M/V, M/D laser	ODKL 96B M/C, M/V, M/D laser
Optical data		
Measurement ranges	300 ... 10000mm (90% diffuse reflection) 300 ... 6000mm (6 ... 90% diffuse reflection)	300 ... 25000mm onto high gain tape
Resolution	3mm	3mm
Light source	laser	laser
Wavelength	658nm (red light)	658nm (red light)
Light spot diameter	divergent, 2 x 6mm ² at 5000mm distance	divergent, 2 x 6mm ² at 5000mm distance
Error limits ¹⁾		
Absolute measurement accuracy ²⁾	± 0.5%	± 0.5%
Repeatability ³⁾	± 5mm	± 5mm
b/w detection thresholds (6%/90%)	± 10mm	–
Temperature drift	± 1.5mm/K	± 1.5mm/K
Timing		
Measurement time	Operating mode "fast": 1.2ms "standard": 10ms "precise": 30ms ⁴⁾	Operating mode "fast": 1.2ms "standard": 10ms "precise": 50ms ⁴⁾
Delay before start-up	£ 300ms	£ 300ms

- 1) After an operating time of 20min., the device has reached the operating temperature required for an optimal measurement.
- 2) Diffuse reflectance 6 ... 90%, entire measurement range, operating mode "precision", sliding window average over 30 measurement values, at 20°C after 20min. warmup time, median range U_B, measurement object ³ 50x50mm²
- 3) Same object, measured object ³ 50x50mm²
- 4) Factory setting

10.3 Electrical data, installation data: triangulation sensors

	ODS(L/R) 96B M/C...	ODS(L/R) 96B M/V...	ODS(L/R) 96B M/D...	ODS(L/R) 96B M(C)66...
Electrical data				
Operating voltage U_B	18 ... 30VDC (incl. residual ripple)			
Residual ripple	£ 15% of U_B			
Bias current	£150mA			
Switching outputs ¹⁾	1 push/pull output, teachable			2 push/pull out- puts, teachable
Signal voltage high/low	³ ($U_B - 2V$) / £ 2V			
Analog output	R_L £ 500Ohm current 4 ... 20mA	R_L ³ 2kOhm voltage 1 ... 10V ²⁾		
Output current	max. 100mA for each push/pull output			
Serial interface RS 232			9600 baud ²⁾ , baud rate con- figurable	
Transmission protocol			2/3 byte trans- mission, const. data flow, see chapter 4.5	
Mechanical data				
Housing	diecast zinc			
Optics cover	glass			
Weight	380g			
Connection type	M12 connector			
Environmental data				
Ambient temp. (operation/storage)	-20 ... +50°C / -30 ... +70°C			
Ambient light limit	³ 5kLux			
Protective circuit ³⁾	1,2,3			
VDE safety class ⁴⁾	II, all-insulated			
Protection class	IP 67, IP 69K ⁵⁾			
Standards applied	IEC 60947-5-2, 21 CFR 1040			

- 1) The push-pull switching outputs must not be connected in parallel
- 2) Factory setting, 1 ... 10V / 0 ... 10V / 1 ... 5V / 0 ... 5V adjustable
- 3) 1=transient protection, 2=polarity reversal protection, 3=short-circuit protection for all outputs
- 4) Rating voltage 250 V AC with closed cover
- 5) IP 69K test acc. to DIN 40050 part 9 simulated, high pressure cleaning conditions without the use of additives, acids and bases are not part of the test.

10.4 Electrical data, installation data: time-of-flight sensors JLTOF

	OD...L 96B M/C...	OD...L 96B M/V...	OD...L 96B M/D...	OD...L 96B M/(C)66...
Electrical data				
Operating voltage U_B	18 ... 30VDC (incl. residual ripple)			
Residual ripple	£ 15% of U_B			
Bias current	£150mA			
Switching outputs ¹⁾	1 push/pull output, teachable			2 push/pull out- puts
Signal voltage high/low	³ ($U_B - 2V$) / £ 2V			
Analog output	current 4 ... 20mA, R_L £ 500Ohm	voltage 1 ... 10V ²⁾ , R_L ³ 2kOhm		
Output current	max. 100mA for each push/pull output			
Serial interface RS 232			9600 baud ²⁾ , baud rate con- figurabile	
Transmission protocol			2/3 byte trans- mission, const. data flow, see chapter 4.5	
Mechanical data				
Housing	diecast zinc			
Optics cover	glass			
Weight	380g			
Connection type	M12 connector			
Environmental data				
Ambient temp. (operation/storage)	-20 ... +50°C / -30 ... +70°C			
Ambient light limit	³ 50kLux			
Protective circuit ³⁾	1,2,3			
VDE safety class ⁴⁾	II, all-insulated			
Protection class	IP 67, IP 69K ⁵⁾			
Standards applied	IEC 60947-5-2			

- 1) The push-pull switching outputs must not be connected in parallel
- 2) Factory setting, 1 ... 10V / 0 ... 10V / 1 ... 5V / 0 ... 5V adjustable
- 3) 1=transient protection, 2=polarity reversal protection, 3=short-circuit protection for all outputs
- 4) Rating voltage 250 V AC with closed cover
- 5) IP 69K test acc. to DIN 40050 part 9 simulated, high pressure cleaning conditions without the use of additives, acids and bases are not part of the test.

10.5 Dimensioned and Connection Drawings

ODS 96B red light and infrared models, triangulation sensors 

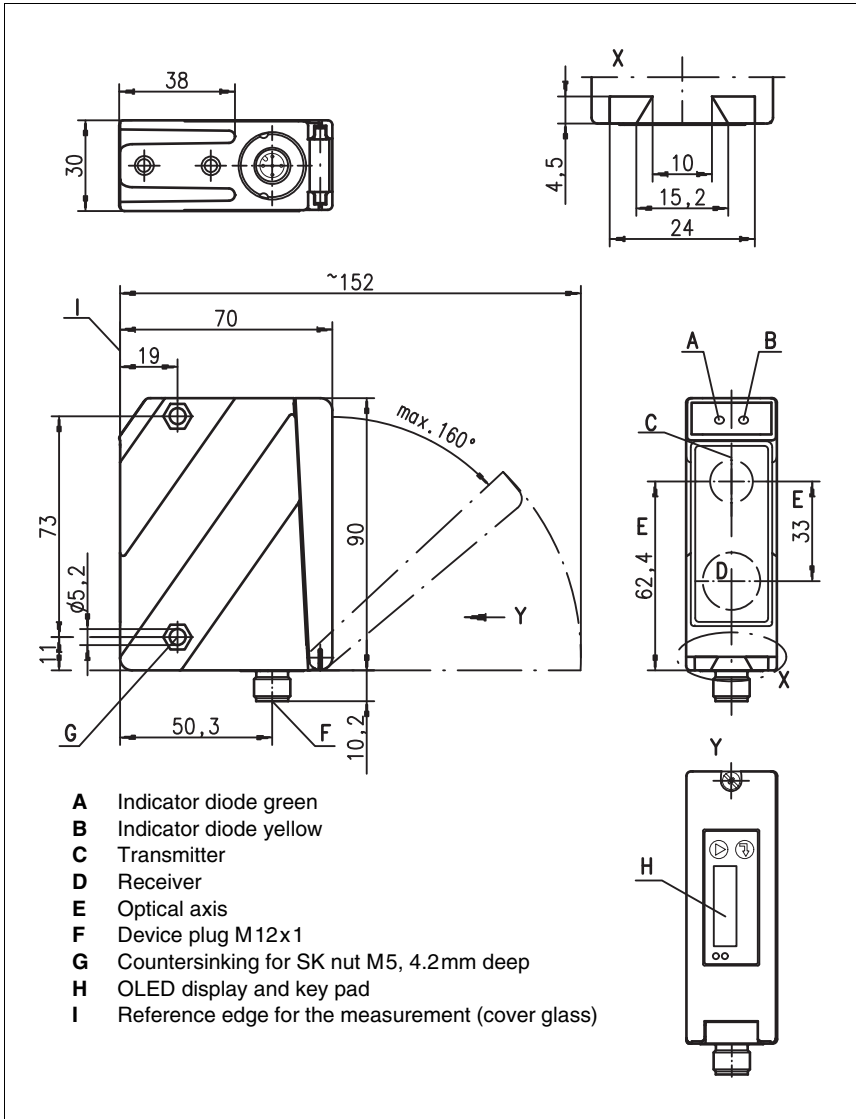

Figure 10.1: Dimensioned drawing ODS 96B..., ODSR 96B...

ODSL... 96B laser models, triangulation sensors **TRI**

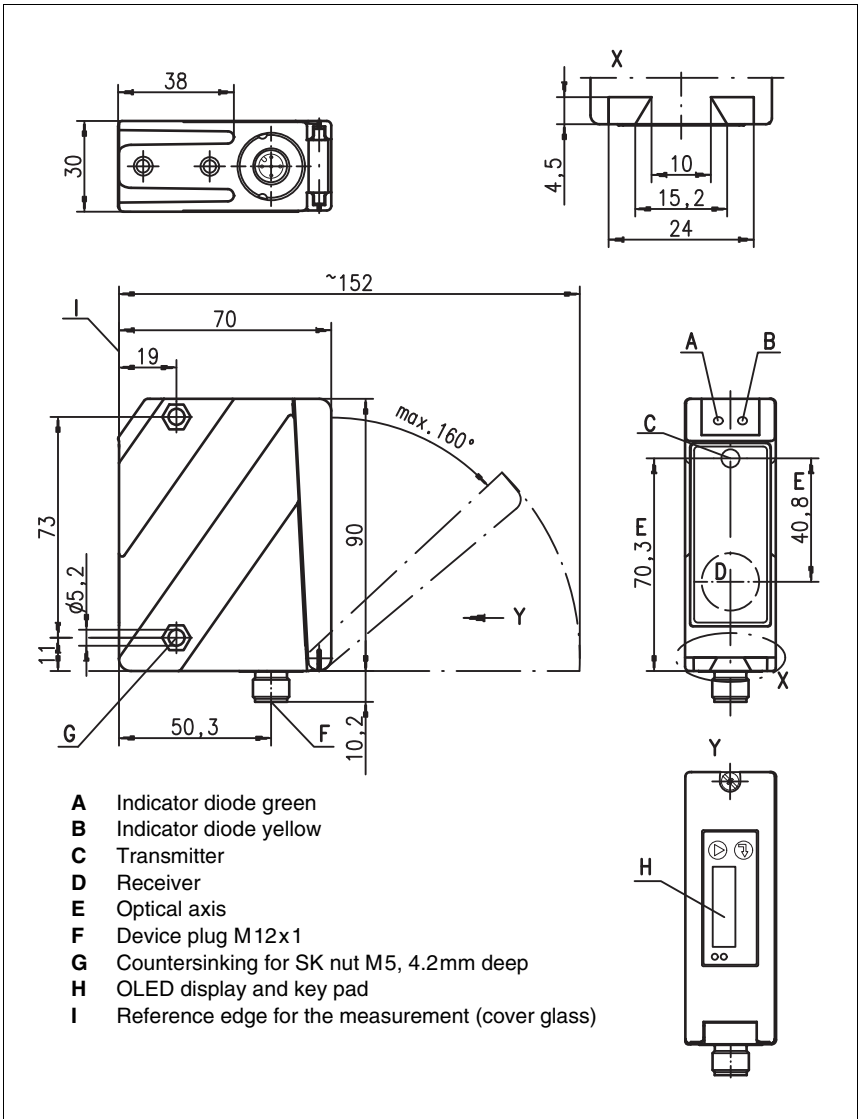

Figure 10.2: Dimensioned drawing triangulation sensors ODSL(R) 96B...

ODSL 96B/ODKL 96B laser models, time-of-flight sensors **∫LTOF**

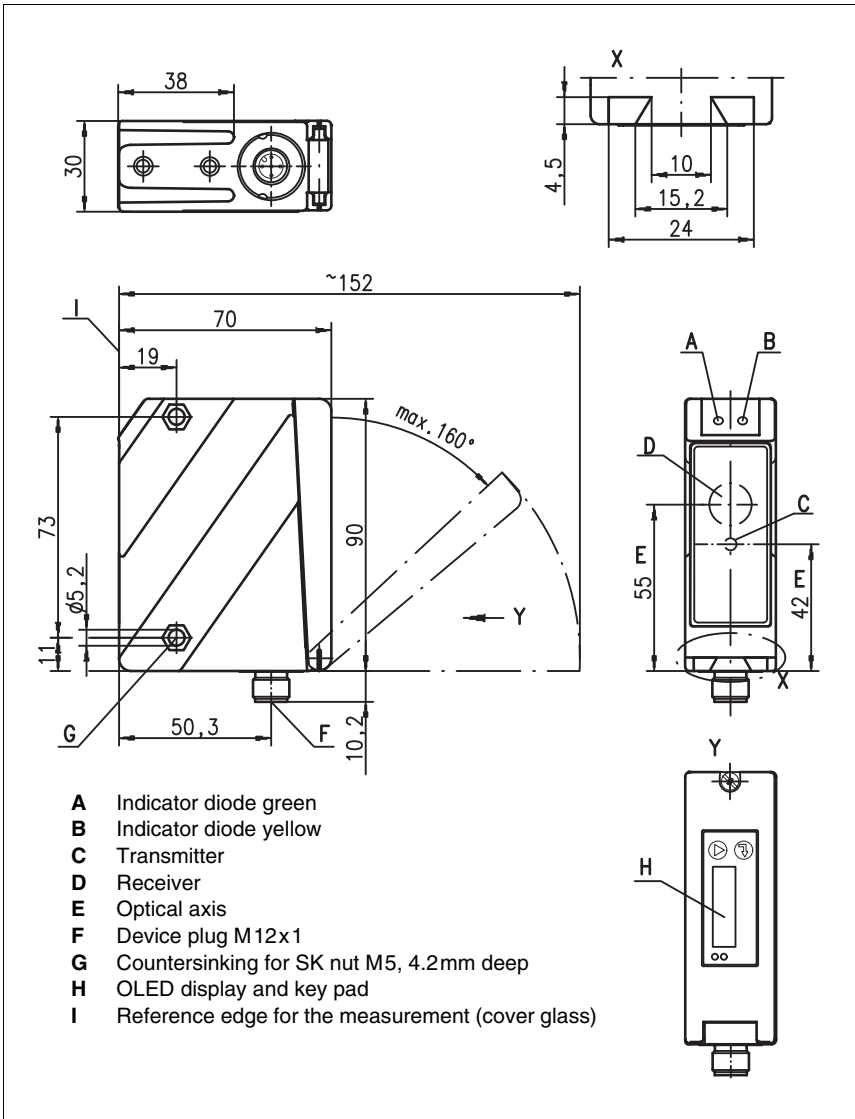

Figure 10.3: Dimensioned drawing time-of-flight sensors ODSL 96B.../ODKL 96B...

ODS... 96B/ODK...96B M/C with analog current output

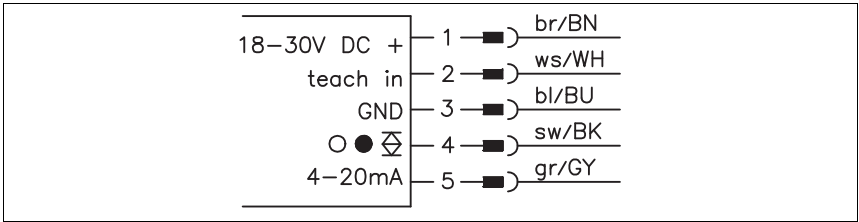

Figure 10.4: Electrical connection ODS... 96B/ODK... 96B M/C...

ODS... 96B/ODK...96B M/C with analog current output and 2 warning or switching outputs

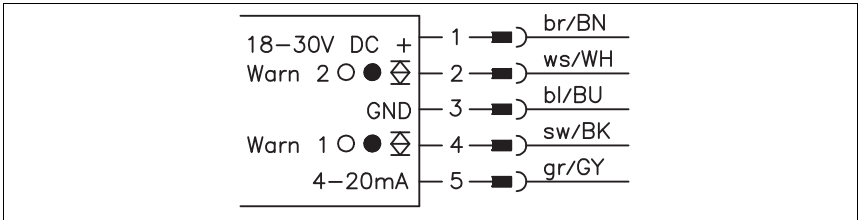

Figure 10.5: Electrical connection ODS... 96B/ODK... 96B M/C66...

ODS... 96B/ODK...96B M/V with analog voltage output

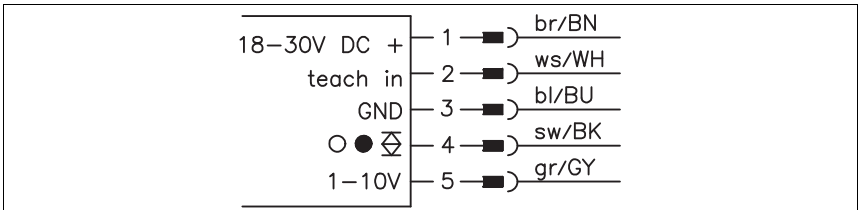

Figure 10.6: Electrical connection ODS... 96B/ODK... 96B M/V...

ODS... 96B/ODK...96B M/D26 with serial RS 232 output

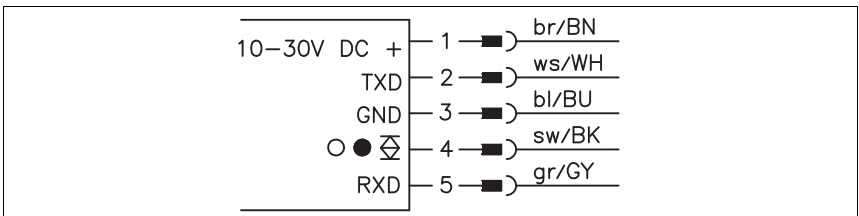

Figure 10.7: Electrical connection ODS... 96B/ODK... 96B M/D26...

ODS... 96B/ODK...96B M/D36 with serial RS 485 output

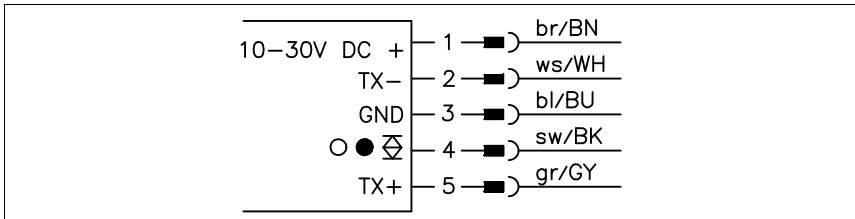

Figure 10.8: Electrical connection ODS... 96B/ODK... 96B M/D36...

ODS... 96B/ODK...96B M/66 with 2 teachable push/pull outputs

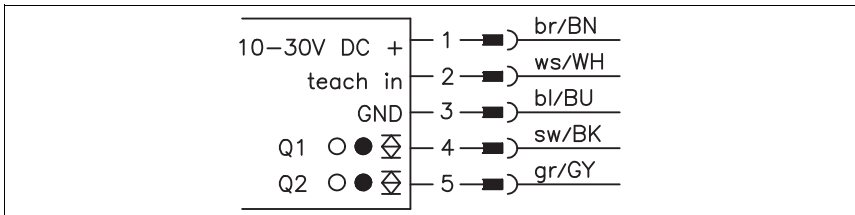

Figure 10.9: Electrical connection ODS... 96B/ODK... 96B M/66...

11 Type overview and accessories

11.1 ODSL 9 type overview

Type designation	Description	Part No.
ODSL 9 with laser transmitter, measurement range 50 ... 450mm		
ODSL 9/C6-450-S12	Measurement range 50 ... 450mm, analog output 4 ... 20mA, 1 teachable push/pull output	50111157
ODSL 9/V6-450-S12	Measurement range 50 ... 450mm, analog output 1 ... 10V, 1 teachable push/pull output	50111158
ODSL 9/D26-450-S12	Measurement range 50 ... 450mm, RS 232 serial connection, 1 push/pull output	50111159
ODSL 9/D36-450-S12	Measurement range 50 ... 450mm, RS 485 serial connection, 1 push/pull output	50111160
ODSL 9/C66-450-S12	Measurement range 50 ... 450mm, analog output 4 ... 20mA, 2 push/pull outputs	50111161
ODSL 9/V66-450-S12	Measurement range 50 ... 450mm, analog output 1 ... 10V, 2 push/pull outputs	50111162
ODSL 9/66-450-S12	Measurement range 50 ... 450mm, 2 teachable push/pull outputs	50111163
ODSL 9 with laser transmitter, measurement range 50 ... 100mm		
ODSL 9/C6-100-S12	Measurement range 50 ... 100mm, analog output 4 ... 20mA, 1 teachable push/pull output	50111167
ODSL 9/V6-100-S12	Measurement range 50 ... 100mm, analog output 1 ... 10V, 1 teachable push/pull output	50111168
ODSL 9/D26-100-S12	Measurement range 50 ... 100mm, RS 232 serial connection, 1 push/pull output	50111169
ODSL 9/D36-100-S12	Measurement range 50 ... 100mm, RS 485 serial connection, 1 push/pull output	50111170
ODSL 9/C66-100-S12	Measurement range 50 ... 100mm, analog output 4 ... 20mA, 2 push/pull outputs	50111171
ODSL 9/V66-100-S12	Measurement range 50 ... 100mm, analog output 1 ... 10V, 2 push/pull outputs	50111172
ODSL 9/66-100-S12	Measurement range 50 ... 100mm, 2 teachable push/pull outputs	50111173

Table 11.1: ODSL 9 type overview

11.2 ODS... 96B/ODK... 96B type overview

11.2.1 Triangulation sensors

Type designation	Description	Part No.
ODS 96B with laser transmitter		
ODSL 96B M/C6-2000-S12	Measurement range 150 ... 2000mm, analog output 4 ... 20mA, 1 teachable push/pull output	50106593
ODSL 96B M/V6-2000-S12	Measurement range 150 ... 2000mm, analog output 1 ... 10V, 1 teachable push/pull output	50106594
ODSL 96B M/D26-2000-S12	Measurement range 150 ... 2000mm, RS 232 serial connection, 1 push/pull output	50106597
ODSL 96B M/D36-2000-S12	Measurement range 150 ... 2000mm, RS 485 serial connection, 1 push/pull output	50106598
ODSL 96B M/66-2000-S12	Measurement range: 150 ... 2000mm, 2 teachable push/pull outputs	50106599
ODSL 96B M/C6-800-S12	Measurement range 100 ... 800mm, analog output 4 ... 20mA, light spot diameter: approx. 1mm, 1 teachable push/pull output	50106728
ODSL 96B M/V6-800-S12	Measurement range 100 ... 800mm, analog output 1 ... 10V, light spot diameter: approx. 1mm, 1 teachable push/pull output	50106729
ODS 96B with infrared LED		
ODS 96B M/C-600-S12	Measurement range 100 ... 600mm, analog output 4 ... 20mA, 1 teachable push/pull output	50106720
ODS 96B M/V-600-S12	Measurement range 100 ... 600mm, analog output 1 ... 10V, 1 teachable push/pull output	50106721
ODS 96B M/D26-600-S12	Measurement range 100 ... 600mm, RS 232 serial connection, 1 push/pull output	50106722
ODS 96B M/D36-600-S12	Measurement range 100 ... 600mm, RS 485 serial connection, 1 push/pull output	50106723
ODS 96B M/66-600-S12	Measurement range: 100 ... 600mm, 2 teachable push/pull outputs	50106724
ODS 96B M/C66.01-1400-S12	Measurement range 120 ... 1400mm, analog output 4 ... 20mA, 2 push/pull warning outputs	50106727
ODS 96B M/V6-1400-S12	Measurement range 120 ... 1400mm, analog output 1 ... 10V, 1 teachable push/pull output	50110231
ODS 96B with red light LED		
ODSR 96B M/C-600-S12	Measurement range 100 ... 600mm, analog output 4 ... 20mA, 1 teachable push/pull output	50106730s
ODSR 96B M/V-600-S12	Measurement range 100 ... 600mm, analog output 1 ... 10V, 1 teachable push/pull output	50106731
ODS 96B with red light laser LED		
ODSLR 96B M/C6-2000-S12	Measurement range 60 ... 2000mm, analog output 4 ... 20mA, 1 teachable push/pull output	50106732
ODSLR 96B M/V6-2000-S12	Measurement range 60 ... 2000mm, analog output 1 ... 10V, 1 teachable push/pull output	50106733

Table 11.2: Type overview triangulation sensors ODS... 96B

11.2.2 Time-of-flight sensors **ILTOF**

Type designation	Description	Part No.
ODSL 96B with laser transmitter, measurement against diffusely reflective objects		
ODSL 96B M/C6-S12	Measurement range 300 ... 6000mm, analog output 4 ... 20mA, 1 teachable push/pull output	50109290
ODSL 96B M/V6-S12	Measurement range 300 ... 6000mm, analog output 1 ... 10V, 1 teachable push/pull output	50109291
ODSL 96B M/D26-S12	Measurement range 300 ... 6000mm, RS 232 serial connection, 1 push/pull output	50109292
ODSL 96B M/D36-S12	Measurement range 300 ... 6000mm, RS 485 serial connection, 1 push/pull output	50109293
ODSL 96B M/C66-S12	Measurement range 300 ... 6000mm, analog output 4 ... 20mA, 2 push/pull outputs	50109295
ODKL 96B with laser transmitter, measurement against high-gain reflective tape		
ODKL 96B M/C6-S12	Measurement range 300 ... 25000mm, analog output 4 ... 20mA, 1 teachable push/pull output	50109297
ODKL 96B M/V6-S12	Measurement range 300 ... 25000mm, analog output 1 ... 10V, 1 teachable push/pull output	50109298
ODKL 96B M/D26-S12	Measurement range 300 ... 25000mm, RS 232 serial connection, 1 push/pull output	50109299
ODKL 96B M/D36-S12	Measurement range 300 ... 25000mm, RS 485 serial connection, 1 push/pull output	50109300
REF 7-A-100x100	Reflective tape for ODKL 96B, cut 100mm x 100mm	50111527

Table 11.3: Type overview time-of-flight sensors OD...L 96B

11.3 Accessories ODSL 9

The following accessories are available for the ODSL 9:

Designation	Order No.	Short descriptions
KD 095-5	50020502	M 12 connector (cable socket), user-configurable, 5-pin, angular
KD 095-5A	50020501	M 12 connector (cable socket), user-configurable, 5-pin, axial
KB-095-5000-5	50020500	Connection lead (M12, angled, 5 m)
KB-095-5000-5A	50020499	Connection lead (M12, axial, 5 m)
K-D M12W-5P-2m-PVC	50104556	PVC connection cable with cable socket on one end, 5-pin, M12, angular, 2 m
K-D M12A-5P-2m-PVC	50104555	PVC connection cable with cable socket on one end, 5-pin, M12, axial, 2 m
K-D M12W-5P-5m-PVC	50104558	PVC connection cable with cable socket on one end, 5-pin, M12, angular, 5 m
K-D M12A-5P-5m-PVC	50104557	PVC connection cable with cable socket on one end, 5-pin, M12, axial, 5 m
K-D M12W-5P-10m-PVC	50104560	PVC connection cable with cable socket on one end, 5-pin, M12, angular, 10 m
K-D M12A-5P-10m-PVC	50104559	PVC connection cable with cable socket on one end, 5-pin, M12, axial, 10 m
K-D M12W-5P-2m-PUR	50104568	PUR connection cable with cable socket on one end, 5-pin, M12, angular, 2 m
K-D M12A-5P-2m-PUR	50104567	PUR connection cable with cable socket on one end, 5-pin, M12, axial, 2 m
K-D M12W-5P-5m-PUR	50104762	PUR connection cable with cable socket on one end, 5-pin, M12, angular, 5 m
K-D M12A-5P-5m-PUR	50104569	PUR connection cable with cable socket on one end, 5-pin, M12, axial, 5 m
BT 8	50036195	Mounting bracket
BT 8-D10	50035017	Mounting system for fastening to rods Ø 10mm or cheeks
BT 8-D12	50035018	Mounting system for fastening to rods Ø 12mm or cheeks
BT 8-D12.5	50106204	Mounting system for fastening to rods Ø 12mm or cheeks
BT 8-D14	50035019	Mounting system for fastening to rods Ø 14mm or cheeks
UPG 10	50107223	Universal programming adapter
ODS 96B Configuration software	Free download under www.leuze.de	Software for easily configuring the ODS 96B from a PC

Table 11.4: Accessories ODSL 9

11.4 Accessories ODS... 96B/ODK... 96B

The following accessories are available for the ODS... 96B/ODK... 96B:

Designation	Order No.	Short descriptions
KD 095-5	50020502	M12 connector (cable socket), user-configurable, 5-pin, angular
KD 095-5A	50020501	M12 connector (cable socket), user-configurable, 5-pin, axial
KB-095-5000-5	50020500	Connection lead (M12, angled, 5m)
KB-095-5000-5A	50020499	Connection lead (M12, axial, 5m)
K-D M12W-5P-2m-PVC	50104556	PVC connection cable with cable socket on one end, 5-pin, M12, angular, 2m
K-D M12A-5P-2m-PVC	50104555	PVC connection cable with cable socket on one end, 5-pin, M12, axial, 2m
K-D M12W-5P-5m-PVC	50104558	PVC connection cable with cable socket on one end, 5-pin, M12, angular, 5m
K-D M12A-5P-5m-PVC	50104557	PVC connection cable with cable socket on one end, 5-pin, M12, axial, 5m
K-D M12W-5P-10m-PVC	50104560	PVC connection cable with cable socket on one end, 5-pin, M12, angular, 10m
K-D M12A-5P-10m-PVC	50104559	PVC connection cable with cable socket on one end, 5-pin, M12, axial, 10m
K-D M12W-5P-2m-PUR	50104568	PUR connection cable with cable socket on one end, 5-pin, M12, angular, 2m
K-D M12A-5P-2m-PUR	50104567	PUR connection cable with cable socket on one end, 5-pin, M12, axial, 2m
K-D M12W-5P-5m-PUR	50104762	PUR connection cable with cable socket on one end, 5-pin, M12, angular, 5m
K-D M12A-5P-5m-PUR	50104569	PUR connection cable with cable socket on one end, 5-pin, M12, axial, 5m
BT 96	50025570	Mounting device
UMS 96	50026204	Universal mounting system
BT 56	50027375	Fixing component with dovetail for rod
BT 59	50111224	Fixing component with dovetail for ITEM profile
UPG 10	50107223	Universal programming adapter
ODS 96B Configuration software	Free download under www.leuze.de	Software for easily configuring the ODS 96B from a PC

Table 11.5: Accessories ODS... 96B/ODK... 96B

12 Appendix

12.1 Updating the ODS configuration software

Update from the Internet

- ↳ Select the Leuze WWW server (<http://www.leuze.com>).
- ↳ Select country and change to the download directory (Download -> Detect -> Measuring sensors).
- ↳ Download the ODS 96B configuration software.
- ↳ Unpack the self-extracting ZIP-file into the program directory.