

MLC 310
Safety light curtains



© 2013

Leuze electronic GmbH + Co. KG

In der Braike 1

D-73277 Owen/Germany

Phone: +49 7021 573-0

Fax: +49 7021 573-199

<http://www.leuze.com>

info@leuze.de

1	About this document.	5
1.1	Used symbols and signal words	5
1.2	Checklists	6
2	Safety	7
2.1	Approved purpose and foreseeable improper operation	7
2.1.1	Proper use	8
2.1.2	Foreseeable misuse	8
2.2	Competent persons	8
2.3	Responsibility for safety	8
2.4	Disclaimer	9
3	Device description	10
3.1	Device overview	10
3.2	Connection technology	11
3.3	Display elements	11
3.3.1	Operating indicators on the MLC 300 transmitter	11
3.3.2	Operating indicators on the MLC 310 receiver	12
4	Functions	14
4.1	Transmission channel changeover	14
4.2	Range reduction	14
5	Applications	15
5.1	Point of operation guarding	15
5.2	Access guarding	15
5.3	Danger zone guarding	16
6	Mounting	17
6.1	Arrangement of transmitter and receiver	17
6.1.1	Calculation of safety distance S	17
6.1.2	Calculation of safety distance S_{RT} or S_{RO} if protective fields act orthogonally to the approach direction	18
6.1.3	Calculation of safety distance S for parallel approach to the protective field	22
6.1.4	Minimum distance to reflective surfaces	23
6.1.5	Preventing mutual interference between adjacent devices	24
6.2	Mounting the safety sensor	25
6.2.1	Suitable mounting locations	25
6.2.2	Definition of directions of movement	26
6.2.3	Fastening via BT-NC60 sliding blocks	26
6.2.4	Fastening with BT-R swivel mount	27
6.2.5	One-sided mounting on the machine table	27
6.3	Mounting accessories	28
6.3.1	Deflecting Mirror for multiple-side guarding	28
6.3.2	MLC-PS protective screen	29
7	Electrical connection	31
7.1	Pin assignment transmitter and receiver	31
7.1.1	MLC 300 transmitter	31
7.1.2	MLC 310 receiver	32
7.2	Circuit diagram examples	33
7.2.1	MLC 310 circuit diagram example	33
8	Starting up the device	34

8.1	Switching on	34
8.2	Aligning the sensor	34
8.3	Aligning of Deflecting Mirrors with the laser alignment aid	35
9	Testing	36
9.1	Before the initial start-up and following modifications	36
9.1.1	Checklist - to be performed prior to the initial start-up and following modifications	36
9.2	To be performed periodically by competent persons	38
9.3	Daily or at change of shift by the operator	38
9.3.1	Check list – daily or at change of shift	38
10	Maintenance	40
11	Rectifying the fault	41
11.1	What to do in case of failure?	41
11.2	Operating displays of the LEDs	41
12	Disposing	42
13	Service and support	43
14	Technical data	44
14.1	General specifications	44
14.2	Dimensions, weight, response time	46
14.3	Dimensional drawings: accessories	48
15	Ordering information and accessories	50
16	EC Declaration of Conformity	55

1 About this document

1.1 Used symbols and signal words

Table 1.1: Warning symbols and signal words

	Symbol indicating dangers to persons
NOTICE	Signal word for property damage Indicates dangers that may result in property damage if the measures for danger avoidance are not followed.
CAUTION	Signal word for minor injury Indicates dangers that may result in minor injury if the measures for danger avoidance are not followed.
WARNING	Signal word for serious injury Indicates dangers that may result in severe or fatal injury if the measures for danger avoidance are not followed.
DANGER	Signal word for life-threatening danger Indicates dangers with which serious or fatal injury is imminent if the measures for danger avoidance are not followed.

Table 1.2: Other symbols



	Symbol for tips Text passages with this symbol provide you with further information.
	Symbols for action steps Text passages with this symbol instruct you to perform actions.

Table 1.3: Terms and abbreviations

AOPD	Active Optoelectronic Protective Device Active Optoelectronic Protective Device
LED	LED, display element in transmitter and receiver
MLC	Brief description of the safety sensor, consisting of transmitter and receiver
MTTF _d	Mean time to a dangerous failure (Mean Time To dangerous Failure)
OSSD	Safety-related switching output (Output Signal Switching Device)
PFH _d	Probability of a dangerous Failure per Hour Probability of dangerous Failure per Hour
PL	Performance Level
Scan	Consecutive scans of the protective field from the first to the last beam
Safety sensor	System consisting of transmitter and receiver
SIL	Safety Integrity Level
State	ON: device intact, OSSD switched on OFF: device intact, OSSD switched off Locking: device, connection or control / operation faulty, OSSD switched off (lock-out)

1.2 Checklists

The checklists (see chapter 9) serve as a reference for the machine manufacturer or supplier. They replace neither testing of the complete machine or system prior to the initial start-up nor their periodic testing by a competent person. The checklists contain minimum testing requirements. Depending on the application, other tests may be necessary.

2 Safety

Before using the safety sensor, a risk assessment must be performed according to valid standards (e.g. EN ISO 12100, EN ISO 13849-1, IEC 61508, EN IEC 62061). The result of the risk assessment determines the required safety level of the safety sensor (see table 14.2). For mounting, operating and testing, this document as well as all applicable national and international standards, regulations, rules and directives must be observed. Relevant and supplied documents must be observed, printed out and handed to affected persons.

 Before working with the safety sensor, completely read and understand the documents applicable to your task.



In particular, the following national and international legal regulations apply for the start-up, technical inspections and work with safety sensors:

- Machinery directive 2006/42/EC
- Low voltage directive 2006/95/EC
- EMC directive 2004/108/EC
- Use of Work Equipment Directive 89/655/EEC supplemented by Directive 95/63 EC
- OSHA 1910 Subpart O
- Safety regulations
- Accident-prevention regulations and safety rules
- Industrial safety regulation and employment protection act
- Product Safety Law (ProdSG)



For safety-related information you may also contact the local authorities (e.g., industrial inspectorate, employer's liability insurance association, labor inspectorate, occupational safety and health authority).

2.1 Approved purpose and foreseeable improper operation

 WARNING
<p>A running machine may result in serious injury!</p> <p> Make certain that the safety sensor is correctly connected and that the protective function of the protective device is ensured.</p> <p> Make certain that, during all conversions, maintenance work and inspections, the system is securely shut down and protected against being restarted.</p>

2.1.1 Proper use

- The safety sensor may only be used after it has been selected in accordance with the respectively applicable instructions and relevant standards, rules and regulations regarding labor protection and safety at work, and after it has been installed on the machine, connected, commissioned, and checked by a **competent person** (see chapter 2.2).
- When selecting the safety sensor it must be ensured that its safety-related capability meets or exceeds the required performance level PL, ascertained in the risk assessment (see table 14.2).
- The safety sensor protects persons or body parts at points of operation, danger zones or access points of machines and plants.
- With the “access guarding” function, the safety sensor detects persons only when they enter the danger zone but cannot tell whether there are any persons inside the danger zone. For this reason, a start/restart interlock in the safety chain is essential in this case.
- The construction of the safety sensor must not be altered. When manipulating the safety sensor, the protective function is no longer guaranteed. Manipulating the safety sensor also voids all warranty claims against the manufacturer of the safety sensor.
- The safety sensor must be inspected regularly by a competent person to ensure proper integration and mounting (see chapter 2.2).
- The safety sensor must be exchanged after a maximum of 20 years. Repairs or the exchange of parts subject to wear and tear do not extend the service life.

2.1.2 Foreseeable misuse

Any use other than that defined under the “Approved purpose” or which goes beyond that use is considered improper use.

In principle, the safety sensor is **not** suitable as a protective device for use in the following cases:

- Danger posed by ejected objects or the spraying of hot or hazardous liquids from within the danger zone
- applications in explosive or easily flammable atmospheres

2.2 Competent persons

Prerequisites for competent persons:

- They have a suitable technical education.
- They know the rules and regulations for occupational safety, safety at work and safety technology and can assess the safety of the machine.
- They know the instructions for the safety sensor and the machine.
- They have been instructed by the responsible person on the mounting and operation of the machine and of the safety sensor.¹

2.3 Responsibility for safety

Manufacturer and operating company must ensure that the machine and implemented safety sensor function properly and that all affected persons are adequately informed and trained.

The type and content of all imparted information must not lead to unsafe actions by users.

The manufacturer of the machine is responsible for:

- safe machine construction
- safe implementation of the safety sensor, verified by the initial test performed by a competent person
- imparting all relevant information to the operating company
- adhering to all regulations and directives for the safe starting-up of the machine

1. They perform a task related to the subject matter shortly thereafter and keep their knowledge up to date through continuous further training.

The operator of the machine is responsible for:

- instructing the operator
- maintaining the safe operation of the machine
- adhering to all regulations and directives for labor protection and safety at work
- regular testing by competent persons

2.4 Disclaimer

Leuze electronic GmbH + Co. KG is not liable in the following cases:

- safety sensor is not used as intended
- safety notices are not adhered to
- reasonably foreseeable misuse is not taken into account
- mounting and electrical connection are not properly performed
- proper function is not tested (see chapter 9)
- changes (e.g., constructional) are made to the safety sensor

3 Device description

The safety sensors from the MLC 300series are active opto-electronic protective devices. They satisfy the following standards:

	MLC 300
Type in accordance with EN IEC 61496	2
Category in accordance with EN ISO 13849	2
Performance Level (PL) in accordance with EN ISO 13849-1	c
Safety Integrity Level (SIL) in accordance with IEC 61508 and SILCL in accordance with EN IEC 62061	1

The safety sensor consists of a transmitter and a receiver (see figure 3.1). It is protected against over-voltage and overcurrent acc. to IEC 60204-1 (safety class 3). Its infrared beams are not influenced by ambient light (e.g. welding sparks, warning lights).

3.1 Device overview

The series is characterized by two different receiver classes (Basic, Standard) with certain features and properties (see table 3.1).

Table 3.1: Device models in the series with specific features and functions

	Transmitter	Receivers	
		Basic	Standard
	MLC 300 MLC 301	MLC 310 MLC 311	MLC 320
OSSDs (2x)		•	•
Transmission channel changeover	•	•	•
LED display	•	•	•
7-segment display			•
Automatic start/restart		•	•
RES			•
EDM			•
Range reduction	•		

Protective field properties

The beam distance and the number of beams are dependent on the resolution and protective field height.

 Depending on the resolution, the effective protective field height can be larger than the optically active area of the safety sensor housed in yellow (see figure 3.1 and see figure 14.1).

Device synchronization

The synchronization of receiver and transmitter for creating a functioning protective field is done optically, i.e. without cables, via two specially coded synchronization beams. A cycle (i.e. a pass from the first to the last beam) is called a scan. The length of a scan determines the length of the response time and affects the calculation of the safety distance (see chapter 6.1.1).

 For the correct synchronization and function of the safety sensor, at least one of the two synchronization beams must be free during synchronization and operation.

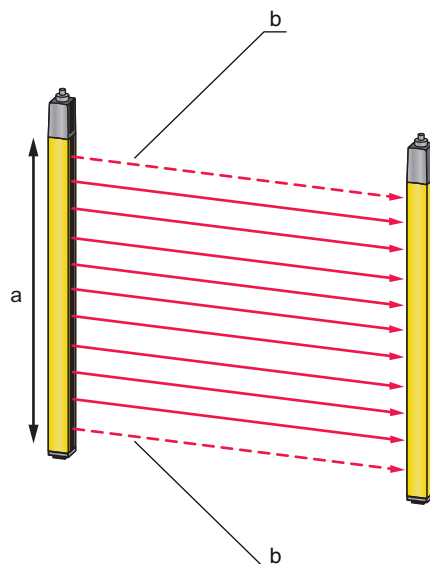

- a Optically active area, housed in yellow
- b Synchronization beams

Figure 3.1: Transmitter-receiver system

QR code

A QR code as well as the corresponding web address are located on the safety sensor (see figure 3.2). At the web address, you will find device information and error messages after scanning the QR code with a mobile end device or after entering the web address. When using mobile end devices, mobile service charges can accrue.



www.mobile.leuze.com/mlc/

Figure 3.2: QR code with corresponding web address (URL) on the safety sensor

3.2 Connection technology

The transmitter and receiver feature an M12 connector as an interface to the machine control with the following number of pins:

Device version	Device type	Device plug
MLC 300	Transmitter	5-pin
MLC 310	Basic receiver	5-pin

3.3 Display elements

The display elements of the safety sensors simplify start-up and fault analysis.

3.3.1 Operating indicators on the MLC 300 transmitter

Two LEDs for displaying the function are located on the connection cap.

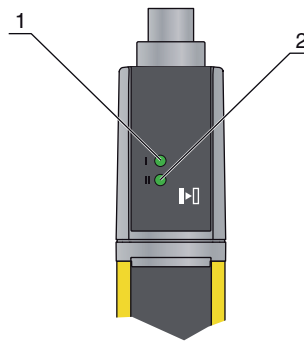

- 1 LED1, green/red
- 2 LED2, green

Figure 3.3: Indicators on the MLC 300 transmitter

Table 3.2: Meaning of the LEDs

LED	Color	State	Description
1	Green/red	OFF	Device switched off
		red	Device error
		green	Normal operation
2	green	Flashing	10 s long after switch-on: reduced range selected by the wiring of pin 4
		OFF	Transmission channel C1
		ON	Transmission channel C2

3.3.2 Operating indicators on the MLC 310 receiver

Located on the receiver are two LEDs for displaying the operating state:

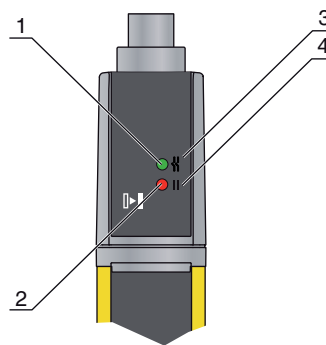

- 1 LED1, red/green
- 2 LED2, red
- 3 OSSD icon
- 4 Transmission channel icon C2

Figure 3.4: Indicators on the receiver MLC 310

Table 3.3: Meaning of the LEDs

LED	Color	State	Description
1	Red/green	OFF	Device switched off
		red	OSSD off
		Red slowly flashing (approx. 1 Hz)	External fault
		Red flashing fast (approx. 10 Hz)	Internal fault
		Green slowly flashing (approx. 1 Hz)	OSSD on, weak signal
		green	OSSD on
2	red	OFF	Transmission channel C1
		ON	OSSD off, transmission channel C2

4 Functions

An overview of features and functions of the safety sensor can be found in chapter “Device description” (see chapter 3.1 „Device overview“).

Depending on the function required, select the suitable operating mode via corresponding electrical wiring (see chapter 7 „Electrical connection“).

Overview of functions

- Range reduction
- Transmission channel changeover

4.1 Transmission channel changeover

Transmission channels are used to prevent mutual interference of safety sensors which are located close to each other.



To guarantee reliable operation, the infrared beams are modulated so they can be discerned from the ambient light. Welding sparks or warning lights, e.g. from passing high-lift trucks, thereby do not influence the protective field.

With the factory setting, the safety sensor works in all operating modes with transmission channel C1.

The transmission channel of the transmitter can be switched by changing the supply voltage polarity (see chapter 7.1.1 „MLC 300 transmitter“).

The transmission channel of the receiver can be switched by changing the supply voltage polarity (see chapter 7.1.2 „MLC 310 receiver“).



Faulty function due to incorrect transmission channel!

Select the same transmission channel on the transmitter and corresponding receiver.

4.2 Range reduction

In addition to selecting the suitable transmission channels (see chapter 4.1 „Transmission channel changeover“), the range reduction also serves to prevent mutual interference of adjacent safety sensors. Activating the function reduces the light power of the transmitter so that around half of the nominal range is reached.

Reducing range:

↪ Wire pin 4 (see chapter 7.1 „Pin assignment transmitter and receiver“).

The wiring of pin 4 determines the transmitting power and thereby the range.

WARNING
<p>Impairment of the protective function due to incorrect transmitting power!</p> <p>The light power emitted from the transmitter is reduced through a single channel and without safety-relevant monitoring.</p> <p>↪ Do not use this configuration option for safety purposes.</p> <p>↪ Note that the distance to reflective surfaces must always be selected so that no reflection bypass can occur even at maximum transmitting power. (see chapter 6.1.4 „Minimum distance to reflective surfaces“)</p>

5 Applications

The safety sensor only creates square protective fields.

5.1 Point of operation guarding

Point of operation guarding for hand and finger protection is typically the most common application for this safety sensor. In accordance with EN ISO 13855, resolutions from 14 to 40 mm make sense here. This yields the necessary safety distance, among others (see chapter 6.1.1 „Calculation of safety distance S“).

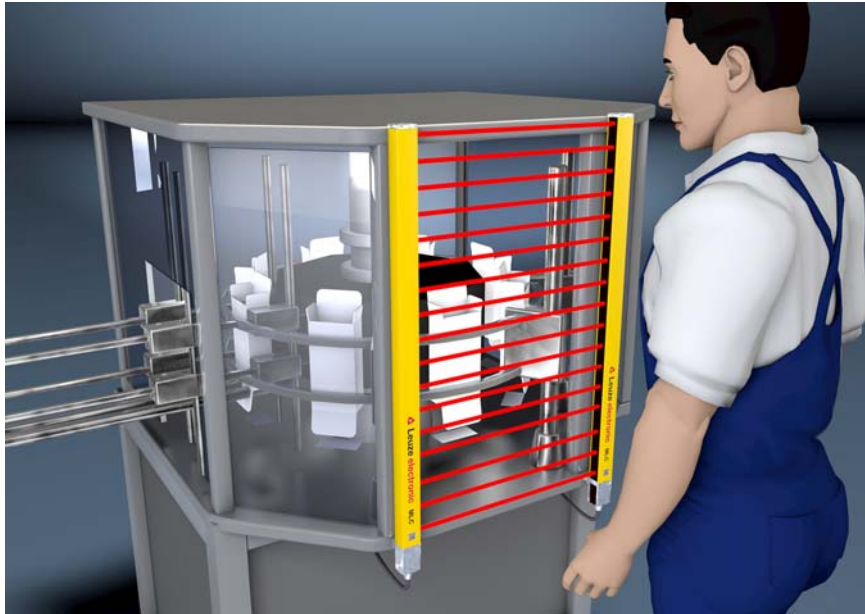

Figure 5.1: Point of operation guarding protects reaching into the danger zone, e.g. for cartoners or filling systems

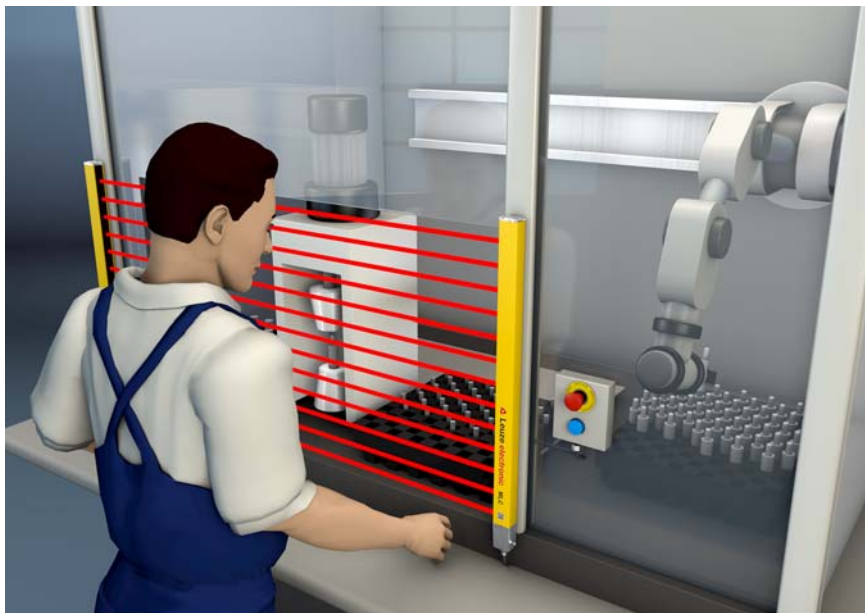

Figure 5.2: Point of operation guarding protects reaching into the danger zone, e.g. for a pick & place robot application

5.2 Access guarding

Safety sensors with up to 90 mm resolution are used for access guarding into danger zones. They detect people only upon entry into the danger zone, i.e., they do not detect parts of a person or whether a person is present in the danger zone.

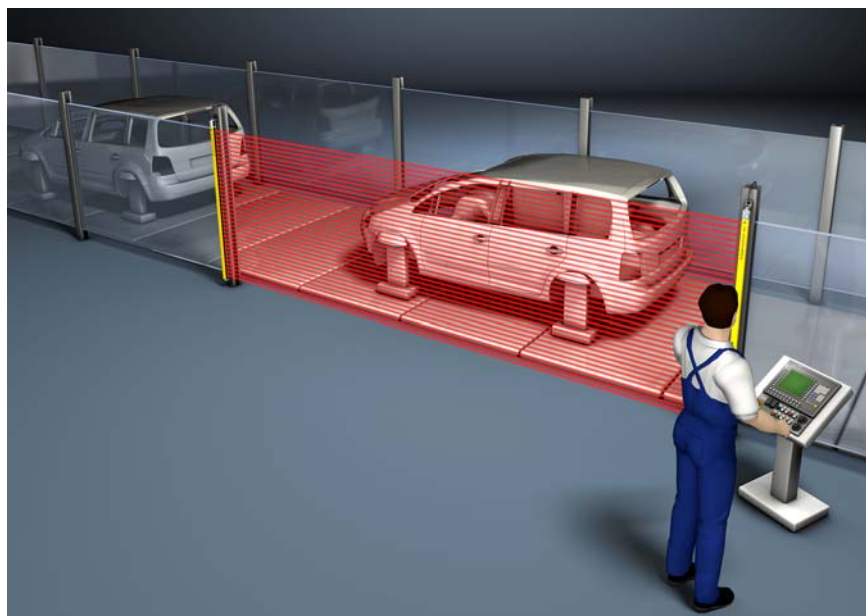

Figure 5.3: Access guarding on a transfer path

5.3 Danger zone guarding

Safety Light Curtains can be used in horizontal arrangement for danger zone guarding - either as stand-alone device for presence monitoring or as stepping behind protection for presence monitoring e.g. in combination with a vertically-arranged safety sensor. Depending on the mounting height, resolutions of 40 or 90 mm are used (see table 15.3).

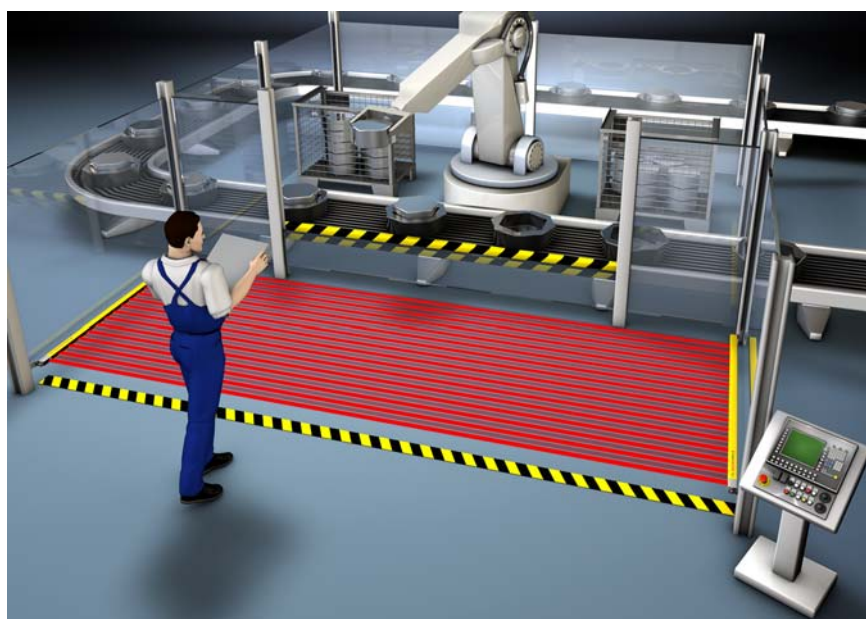

Figure 5.4: Danger zone guarding on a robot

6 Mounting

WARNING

Improper mounting may result in serious injury!

The protective function of the safety sensor is only ensured if appropriately and professionally mounted for the respective, intended area of application.

- ↳ Only allow competent persons to install the safety sensor.
- ↳ Maintain the necessary safety distances (see chapter 6.1.1).
- ↳ Make sure that stepping behind, crawling under or stepping over the protective device is reliably ruled out and reaching under, over or around is taken into account in the safety distance, if applicable with additional distance C_{RO} corresponding to EN ISO 13855.
- ↳ Take measures to prevent that the safety sensor can be used to gain access to the danger zone, e.g. by stepping or climbing into it.
- ↳ Observe the relevant standards, regulations and these instructions.
- ↳ Clean the transmitter and receiver at regular intervals: environmental conditions (see chapter 14), care (see chapter 10).
- ↳ After mounting, check the safety sensor for proper function.

6.1 Arrangement of transmitter and receiver

Optical protective devices can only perform their protective function if they are mounted with adequate safety distance. When mounting, all delay times must be taken into account, such as the response times of the safety sensor and control elements as well as the stopping time of the machine, among others.

The following standards specify calculation formulas:

- prEN IEC 61496-2, "Active Optoelectronic Protective Devices": distance of the reflecting surfaces/ Deflecting Mirrors
- EN 13855, "Safety of machines - The positioning of protective equipment in respect of approach speeds of parts of the human body": mounting situation and safety distances



In accordance with ISO 13855, with a vertical protective field, it is possible to pass under beams over 300 mm or pass over beams under 900 mm. If the protective field is horizontal, climbing on the safety sensor must be prevented through suitable installation or with covers and the like.

6.1.1 Calculation of safety distance S

General formula for calculating the safety distance S of an Optoelectronic Protective Device acc. to EN ISO 13855:

$$S = K \cdot T + C$$

S	[mm]	= Safety distance
K	[mm/s]	= Approach speed
T	[s]	= Total time of the delay, sum from ($t_a + t_i + t_m$)
t_a	[s]	= Response time of the protective device
t_i	[s]	= Response time of the Safety Relay
t_m	[s]	= Stopping time of the machine
C	[mm]	= Additional distance to the safety distance



If longer stopping times are determined during regular inspections, an appropriate additional time must be added to t_m .

6.1.2 Calculation of safety distance S_{RT} or S_{RO} if protective fields act orthogonally to the approach direction

With vertical protective fields, EN ISO 13855 differentiates between

- S_{RT} : safety distance concerning access **through** the protective field
- S_{RO} : safety distance concerning access **over** the protective field

The two values are distinguished by the way additional distance C is determined:

- C_{RT} : from a calculation formula or as a constant see chapter 6.1.1 „Calculation of safety distance S“
- C_{RO} : from a table (see table 6.1)

The larger of the two values S_{RT} and S_{RO} is to be used.

Calculation of safety distance S_{RT} acc. to EN ISO 13855 when access occurs through the protective field:

Calculation of safety distance S_{RT} for point of operation guarding

$$S_{RT} = K \cdot T + C_{RT}$$

S_{RT}	[mm]	= Safety distance
K	[mm/s]	= Approach speed for point of operation guarding with approach reaction and normal approach direction to the protective field (resolution 14 to 40 mm): 2000 mm/s or 1600 mm/s, when $S_{RT} > 500$ mm
T	[s]	= Total time of the delay, sum from ($t_a + t_i + t_m$)
t_a	[s]	= Response time of the protective device
t_i	[s]	= Response time of the Safety Relay
t_m	[s]	= Stopping time of the machine
C_{RT}	[mm]	= Additional distance for point of operation guarding with approach reaction with resolutions of 14 to 40 mm, d = resolution of protective device $C_{RT} = 8 \cdot (d - 14)$ mm

Calculation example

The feeding-in area in a press with a stopping time (including press Safety PLC) of 190 ms is to be safeguarded with a Safety Light Curtain with 20 mm of resolution and 1200 mm of protective field height. The Safety Light Curtain has a response time of 22 ms.

↳ Calculate safety distance S_{RT} using the formula acc. to EN ISO 13855.

$$S_{RT} = K \cdot T + C_{RT}$$

K	[mm/s]	= 2000
T	[s]	= (0.022 + 0.190)
C_{RT}	[mm]	= $8 \cdot (20 - 14)$
S_{RT}	[mm]	= $2000 \text{ mm/s} \cdot 0.212 \text{ s} + 48 \text{ mm}$
S_{RT}	[mm]	= 472

S_{RT} is smaller than 500 mm; this is why the calculation may **not** be repeated with 1600 mm/s.



Implement the stepping behind protection required here, e.g., through the use of an additional or cascaded safety sensor for area protection.

Calculation of safety distance S_{RT} for access guarding

$$S_{RT} = K \cdot T + C_{RT}$$

S_{RT}	[mm]	= Safety distance
K	[mm/s]	= Approach speed for access guarding with approach direction orthogonal to the protective field: 2000 mm/s or 1600 mm/s, if $S_{RT} > 500$ mm
T	[s]	= Total time of the delay, sum from ($t_a + t_i + t_m$)
t_a	[s]	= Response time of the protective device
t_i	[s]	= Response time of the Safety Relay
t_m	[s]	= Stopping time of the machine
C_{RT}	[mm]	= Additional distance for access guarding with approach reaction with resolutions of 14 to 40 mm, d = resolution of protective device $C_{RT} = 8 \cdot (d - 14)$ mm. Additional dis-

tance for access guarding for resolutions > 40 mm: $C_{RT} = 850$ mm (standard value for arm length)

Calculation example

Access to a robot with a stopping time of 250 ms is to be safeguarded with a Safety Light Curtain with 90 mm of resolution and 1500 mm of protective field height whose response time is 6 ms. The Safety Light Curtain directly switches the contactors whose response time is contained in the 250 ms. An additional interface therefore does not have to be taken into consideration.

↪ Calculate safety distance S_{RT} using the formula acc. to EN ISO 13855.

$$S_{RT} = K \cdot T + C_{RT}$$

K	[mm/s]	= 1600
T	[s]	= (0.006 + 0.250)
C_{RT}	[mm]	= 850
S_{RT}	[mm]	= 1600 mm/s · 0.256 s + 850 mm
S_{RT}	[mm]	= 1260

This safety distance is not available in the application. This is why a new calculation is done with a Safety Light Curtain with 40 mm of resolution (response time = 14 ms):

↪ Re-calculate safety distance S_{RT} using the formula acc. to EN ISO 13855.

$$S_{RT} = K \cdot T + C_{RT}$$

K	[mm/s]	= 1600
T	[s]	= (0.014 + 0.250)
C_{RT}	[mm]	= 8 · (40 - 14)
S_{RT}	[mm]	= 1600 mm/s · 0.264 s + 208 mm
S_{RT}	[mm]	= 631

The Safety Light Curtain with a 40 mm resolution is thus suitable for this application.



For the calculation with $K = 2000$ mm/s, safety distance S_{RT} equals 736 mm. The adoption of approach speed $K = 1600$ mm/s is therefore permitted.

Calculation of safety distance S_{RO} acc. to EN ISO 13855 when protective field is accessed from above:

Calculation of safety distance S_{RT} for point of operation guarding

$$S_{RO} = K \cdot T + C_{RO}$$

S_{RO}	[mm]	= Safety distance
K	[mm/s]	= Approach speed for point of operation guarding with approach reaction and normal approach direction to the protective field (resolution 14 to 40 mm): 2000 mm/s or 1600 mm/s, when $S_{RO} > 500$ mm
T	[s]	= Total time of the delay, sum from ($t_a + t_i + t_m$)
t_a	[s]	= Response time of the protective device
t_i	[s]	= Response time of the Safety Relay
t_m	[s]	= Stopping time of the machine
C_{RO}	[mm]	= Additional distance in which a body part can move towards the protective device before the protective device triggers: value (see table 6.1)

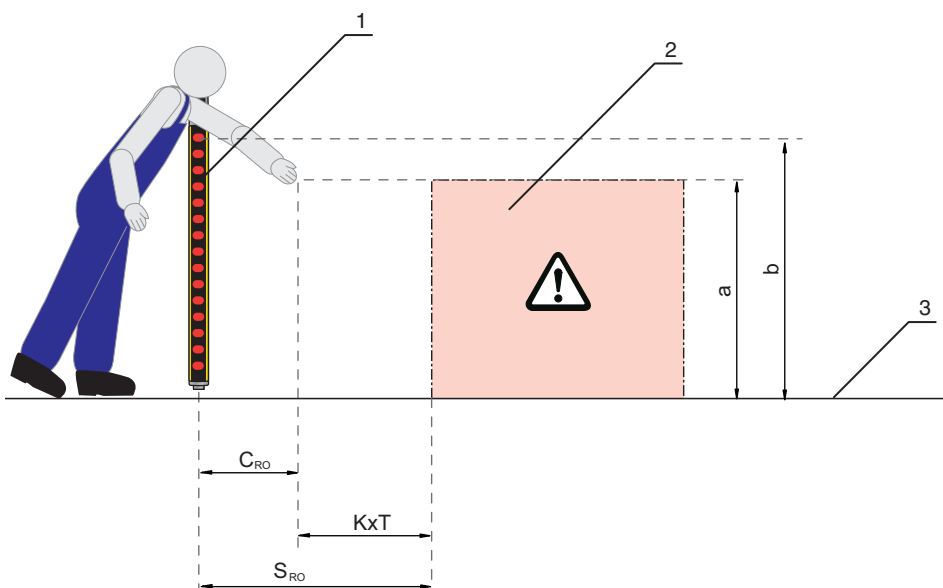

- 1 Safety sensor
- 2 Danger zone
- 3 Floor
- a Height of the point of operation
- b Height of the upper beam of the safety sensor

Figure 6.1: Additional distance to the safety distance when reaching over and under

Table 6.1: Reaching over the vertical protective field of electro-sensitive protective equipment(excerpt from EN ISO 13855)

Height a of the point of operation [mm]	Height b of the upper edge of the protective field of the electro-sensitive protective equipment											
	900	1000	1100	1200	1300	1400	1600	1800	2000	2200	2400	2600
Additional distance C_{RO} to the danger zone [mm]												
2600	0	0	0	0	0	0	0	0	0	0	0	0
2500	400	400	350	300	300	300	300	300	250	150	100	0
2400	550	550	550	500	450	450	400	400	300	250	100	0
2200	800	750	750	700	650	650	600	550	400	250	0	0
2000	950	950	850	850	800	750	700	550	400	0	0	0
1800	1100	1100	950	950	850	800	750	550	0	0	0	0
1600	1150	1150	1100	1000	900	850	750	450	0	0	0	0
1400	1200	1200	1100	1000	900	850	650	0	0	0	0	0
1200	1200	1200	1100	1000	850	800	0	0	0	0	0	0
1000	1200	1150	1050	950	750	700	0	0	0	0	0	0
800	1150	1050	950	800	500	450	0	0	0	0	0	0
600	1050	950	750	550	0	0	0	0	0	0	0	0

Height a of the point of operation [mm]	Height b of the upper edge of the protective field of the electro-sensitive protective equipment											
	900	1000	1100	1200	1300	1400	1600	1800	2000	2200	2400	2600
	Additional distance C_{RO} to the danger zone [mm]											
400	900	700	0	0	0	0	0	0	0	0	0	0
200	600	0	0	0	0	0	0	0	0	0	0	0
0	0	0	0	0	0	0	0	0	0	0	0	0

Depending on the specified values you can work with the above-mentioned table (see table 6.1) in three ways:

1. Given are

- Height a of the point of operation
- Distance S of the point of operation from the safety sensor, and additional distance C_{RO}

To be determined is the required height b of the upper beam of the safety sensor and thereby its protective field height.

- ↪ Look for the line with the specification of the point of operation height in the left column.
- ↪ In this line, look for the column with the next highest specification for additional distance C_{RO} .
- The required height of the upper beam of the safety sensor is up top in the column head.

2. Given are

- Height a of the point of operation
- Height b of the upper beam of the safety sensor

To be determined is the required distance S of the safety sensor to the point of operation and thereby additional distance C_{RO} .

- ↪ In the column head, look for the column with the next lowest entry for the height of the upper beam of the safety sensor.
- ↪ Look for the line with the next highest specification of the point of operation height a in this column.
- In the intersection point of the line and the column, you will find additional distance C_{RO} .

3. Given are

- Distance S of the point of operation from the safety sensor, and additional distance C_{RO}
- Height b of the upper beam of the safety sensor

To be determined is the permitted height a of the point of operation.

- ↪ In the column head, look for the column with the next lowest entry for the height of the upper beam of the safety sensor.
- ↪ Look for the next lowest value for real additional distance C_{RO} in this column.
- In this line, go to the left column: here you will find the permitted height of the point of operation.
- ↪ Now calculate safety distance S using the general formula acc. to EN ISO 13855, see chapter 6.1.1 „Calculation of safety distance S“.

The larger of the two values SRT or S_{RO} is to be used.

Calculation example

The feeding-in area in a press with a stopping time of 130 ms is to be safeguarded with a Safety Light Curtain with 20 mm of resolution and 600 mm of protective field height. The response time of the Safety Light Curtain is 12 ms; the press Safety PLC has a response time of 40 ms.

The safety sensor can be reached over. The upper edge of the protective field is located at a height of 1400 mm; the point of operation is located at a height of 1000 mm

→ Additional distance C_{RO} to the point of operation is 700 mm (see table 6.1).

- ↪ Calculate safety distance S_{RO} using the formula acc. to EN ISO 13855.

$$S_{RO} = K \cdot T + C_{RO}$$

K	[mm/s]	= 2000
T	[s]	= (0.012 + 0.040 + 0.130)
C _{RO}	[mm]	= 700
S _{RO}	[mm]	= 2000 mm/s · 0.182 s + 700 mm
S_{RO}	[mm]	= 1064

S_{RO} is larger than 500 mm; this is why the calculation may be repeated with approach speed 1600 mm/s:

$$S_{RO} = K \cdot T + C_{RO}$$

K	[mm/s]	= 1600
T	[s]	= (0.012 + 0.040 + 0.130)
C _{RO}	[mm]	= 700
S _{RO}	[mm]	= 1600 mm/s · 0.182 s + 700 mm
S_{RO}	[mm]	= 992



Depending on the machine construction, stepping behind protection, e.g. using a second horizontally arranged Safety Light Curtain, is necessary. In most cases, it will be more appropriate to choose a longer Safety Light Curtain which makes the additional distance C_{RO} equal to 0.

6.1.3 Calculation of safety distance S for parallel approach to the protective field

Calculation of safety distance S for danger zone guarding

$$S = K \cdot T + C$$

S	[mm]	= Safety distance
K	[mm/s]	= Approach speed for danger zone guarding with approach direction parallel to the protective field (resolution up to 90 mm): 1600 mm/s
T	[s]	= Total time of the delay, sum from (t _a + t _i + t _m)
t _a	[s]	= Response time of the protective device
t _i	[s]	= Response time of the Safety Relay
t _m	[s]	= Stopping time of the machine
C	[mm]	= Additional distance for danger zone guarding with approach reaction H = height of the protective field, H _{min} = minimum installation height permitted, but no smaller than 0, d = resolution of the protective device C = 1200 mm - 0.4 · H; H _{min} = 15 · (d - 50)

Calculation example

The danger zone in front of a machine with a stopping time of 140 ms is to be safeguarded as close to the floor height as possible using a horizontal Safety Light Curtain as a replacement for a PS mat. Installation height H_{min} can be = 0 - additional distance C to the safety distance is then 1200 mm. The shortest possible safety sensor is to be used; the first value to be selected is to be 1350 mm.

The receiver with 40 mm of resolution and 1350 mm protective field height has a response time of 13 ms, an additional MSI-SR4 relay interface a response time of 10 ms.

↪ Calculate safety distance S_{RO} using the formula acc. to EN ISO 13855.

$$S = K \cdot T + C$$

K	[mm/s]	= 1600
T	[s]	= (0.140 + 0.013 + 0.010)
C	[mm]	= 1200
S	[mm]	= 1600 mm/s · 0.163 s + 1200 mm
S	[mm]	= 1461

The safety distance of 1350 mm is not sufficient; 1460 mm are necessary.

This is why the calculation is repeated with a protective field height of 1500 mm. The response time is now 14 ms.

↪ Re-calculate safety distance S_{RO} using the formula according to EN ISO 13855.

$$S = K \cdot T + C$$

K	[mm/s]	= 1600
T	[s]	= (0.140 + 0.014 + 0.010)
C	[mm]	= 1200
S	[mm]	= 1600 mm/s · 0.164 s + 1200 mm
S	[mm]	= 1463

A suitable safety sensor has been found; its protective field height is 1500 mm.

6.1.4 Minimum distance to reflective surfaces

⚠ WARNING

Failure to maintain minimum distances to reflective surfaces may result in serious injury!

Reflective surfaces can indirectly deflect the transmitter beams to the receiver. In this case, interruption of the protective field is not detected.

↪ Determine the minimum distance a (see figure 6.2).

↪ Make certain that all reflective surfaces are the necessary minimum distance away from the protective field according to prEN IEC 61496-2 (see figure 6.3).

↪ Check that reflective surfaces do not impair the detection capability of the safety sensor before start-up and at appropriate intervals.

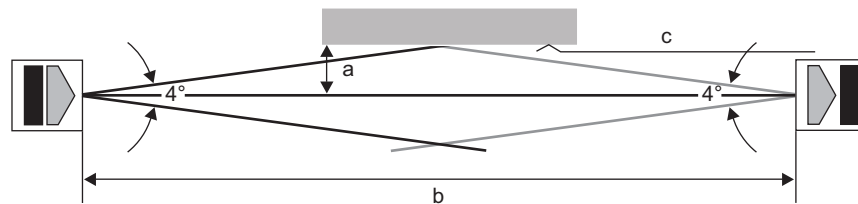

- a Required minimum distance to reflective surfaces [mm]
- b Protective field width [m]
- c Reflective surface

Figure 6.2: Minimum distance to reflective surfaces depending on protective field width

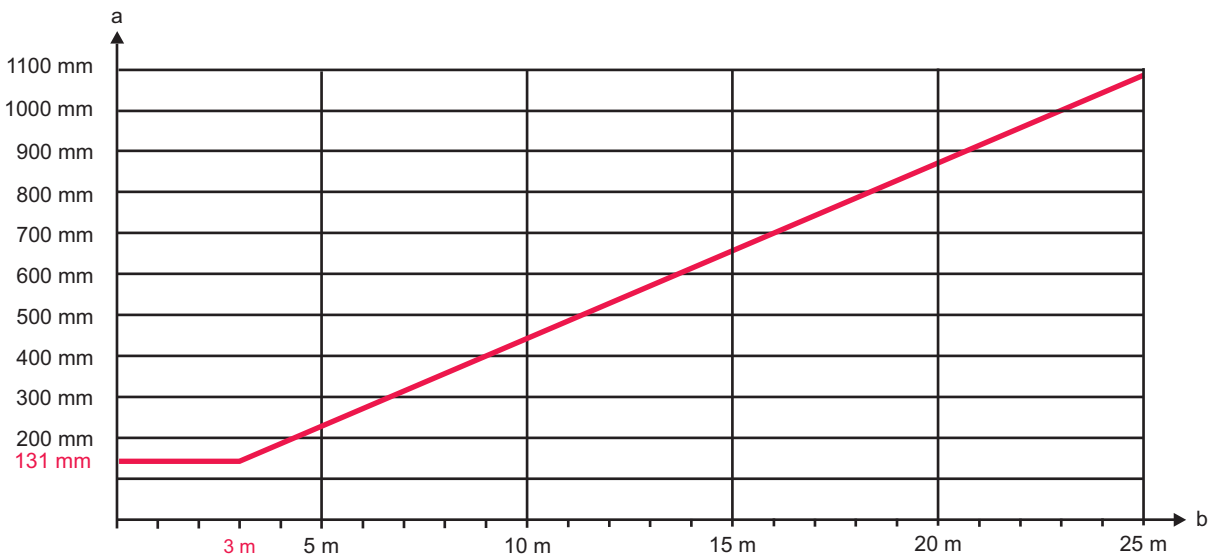

- a Required minimum distance to reflective surfaces [mm]
- b Protective field width [m]

Figure 6.3: Minimum distance to reflective surfaces as a function of the protective field width

Table 6.2: Formula for calculating the minimum distance to reflective surfaces

Distance (b) transmitter-receiver	Calculation of the minimum distance (a) to reflective surfaces
$b \leq 3 \text{ m}$	$a \text{ [mm]} = 131$
$b > 3 \text{ m}$	$a \text{ [mm]} = \tan(2.5^\circ) \cdot 1000 \cdot b \text{ [m]} = 43.66 \cdot b \text{ [m]}$

6.1.5 Preventing mutual interference between adjacent devices

If a receiver is located in the beam path of an adjacent transmitter, optical crosstalk, and thus erroneous switching and failure of the protective function, may result (see figure 6.4).

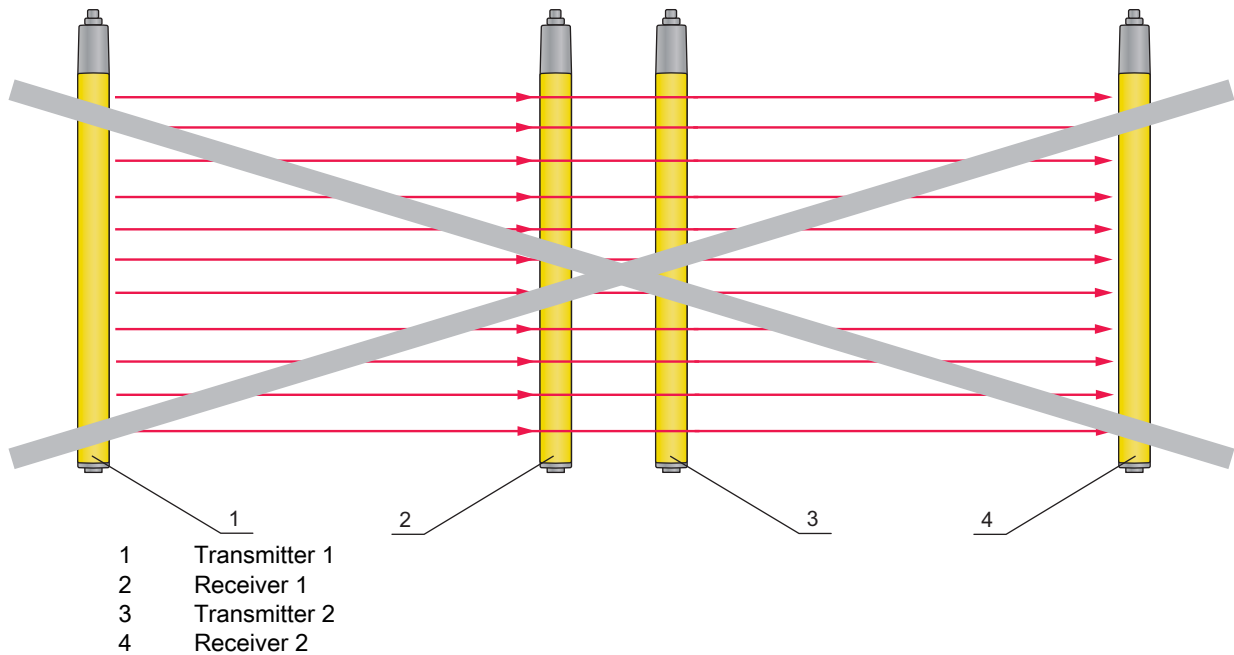

Figure 6.4: Optical crosstalk between adjacent safety sensors (transmitter 1 influences receiver 2) due to incorrect mounting

NOTICE
Possible impairment of the availability due to systems mounted close to each other!
The transmitter of one system can influence the receiver of the other system.
↪ Prevent optical crosstalk between adjacent devices.

↪ Mount adjacent devices with a shield between them or install a dividing wall to prevent mutual interference.

↪ Mount the adjacent devices opposite from one another to prevent mutual interference.

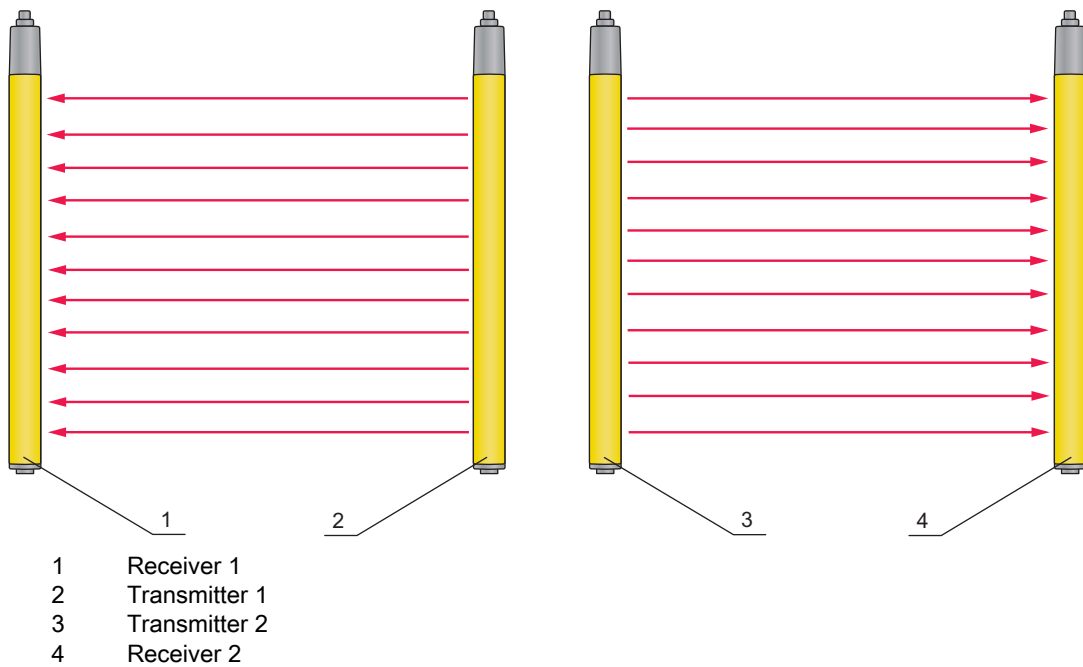

Figure 6.5: Opposite mounting

In addition to design characteristics, the safety sensor offers functions that can remedy this:

- Selectable transmission channels (see chapter 4.1)
- Range reduction (see chapter 4.2)
- Also: opposite mounting

6.2 Mounting the safety sensor

Proceed as follows:

- Select the type of fastening, e.g. sliding blocks (see chapter 6.2.3).
- Have a suitable tool at hand and mount the safety sensor in accordance with the notices regarding the mounting locations (see chapter 6.2.1).
- If possible, affix safety notice stickers on the mounted safety sensor or Device Column (included in delivery contents).

After mounting, you can electrically connect (see chapter 7), start up, align (see chapter 8 „Starting up the device“), and test (see chapter 9.1) the safety sensor.

6.2.1 Suitable mounting locations

Area of application: Mounting

Tester: technician who mounts the safety sensor

Table 6.3: Checklist for mounting preparations

Check:	Yes	No
Do the protective field height and dimensions satisfy the requirements of EN 13855?		
Is the safety distance to the point of operation maintained (see chapter 6.1.1)?		
Is the minimum distance to reflective surfaces maintained (see chapter 6.1.4)?		
Is it impossible for safety sensors that are mounted next to one another to mutually interfere with one another (see chapter 6.1.5)?		
Can the point of operation or the danger zone only be accessed through the protective field?		

Check:	Yes	No
Has bypassing the protective field by crawling under, reaching over, or jumping over been prevented or has corresponding additional distance C_{RO} in accordance with EN ISO 13855 been observed?		
Is stepping behind the protective device prevented or is mechanical protection available?		
Do the transmitter and receiver connections point in the same direction?		
Can the transmitter and receiver be fastened in such a way that they cannot be moved and turned?		
Is the safety sensor accessible for testing and replacing?		
Is it impossible to actuate the reset button from within the danger zone?		
Can the entire danger zone be seen from the installation site of the reset button?		
Can reflection caused by the installation site be ruled out?		

i If you answer one of the items on the check list (see table 6.3) with *no*, the mounting location must be changed.

6.2.2 Definition of directions of movement

The following terms for alignment movements of the safety sensor around one of its axes are used:

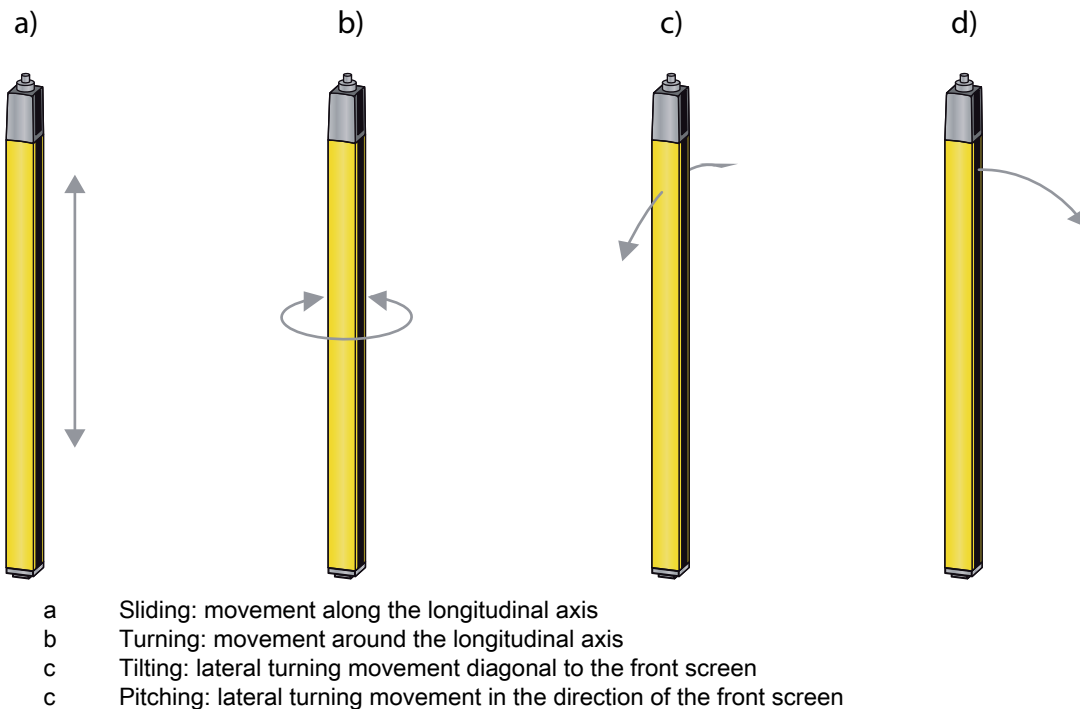

Figure 6.6: Directions of movement during alignment of the safety sensor

6.2.3 Fastening via BT-NC60 sliding blocks

By default, transmitter and receiver are delivered with 2 BT-NC60 sliding blocks each in the side slot. This makes fastening the safety sensor to the machine or system to be safeguarded easy via four M6 screws. Sliding in the direction of slot to set the height is possible, but turning, tilting and pitching is not.

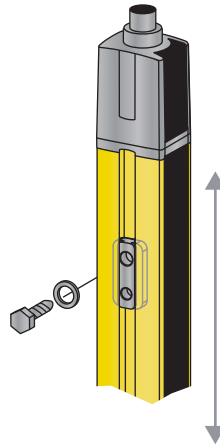

Figure 6.7: Mounting via BT-NC60 sliding blocks

6.2.4 Fastening with BT-R swivel mount

With the swivel mount (see table 15.5), sold separately, the safety sensor can be aligned as follows:

- Sliding through the vertical threaded holes in the wall plate of the swivel mount
- Turning by 360° around the longitudinal axis by fixing on the screw-on cone
- Pitching in the direction of the protective field with horizontal threaded holes in the wall mounting
- Tilting around main axis

The wall mounting through threaded holes makes it possible to lift the mounting bracket after the screws have been loosened over the connection cap. Therefore, the mounting brackets do not need to be removed from the wall when exchanging the device. Loosening the screws is sufficient.

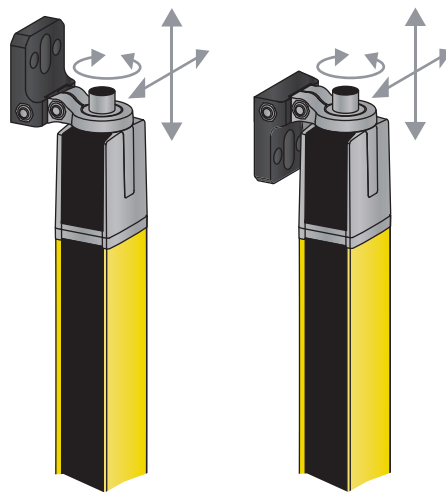

Figure 6.8: Mounting via BT-R swivel mount

6.2.5 One-sided mounting on the machine table

The safety sensor can be mounted directly on the machine table via an M5 screw on the blind hole in the end cap. On the other end, a BT-R swivel mount can be used, for example, so that turning movements for alignment are possible despite the fact that the sensor is mounted on one side. The full resolution of the safety sensor is thus preserved on all points of the protective field down to the machine table.

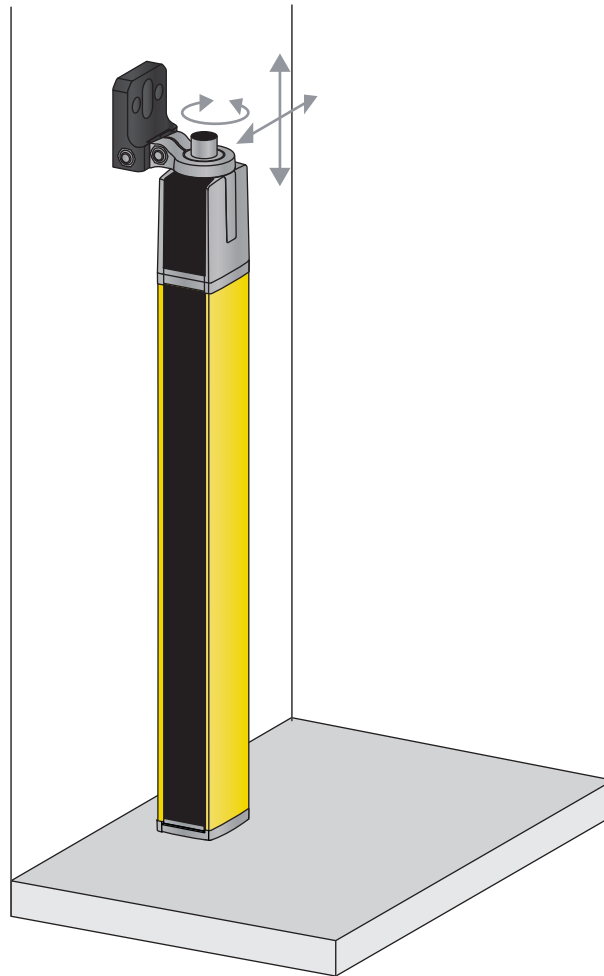

Figure 6.9: Mounting directly on the machine table



WARNING

Impairment of the protective function due to reflections on the machine table!

- ↳ Make sure that reflections on the machine table are prevented reliably.
- ↳ After mounting and every day after that, check the detection capability of the safety sensor in the entire protective field using a test rod (see figure 9.1).

6.3 Mounting accessories

6.3.1 Deflecting Mirror for multiple-side guarding

For multiple-side guarding, redirecting the protective field with one or two Deflecting Mirrors is economical. To do this, Leuze electronic supplies

- the UM60 Deflecting Mirror for mounting on the machine in various lengths (see table 15.5)
- suitable BT-UM60 swivel mounts
- UMC-1000-S2 ... UMC-1900-S2 Deflecting Mirror Columns with spring-damped base for free-standing floor mounting

The range is reduced by approx. 10 % per deflection. A laser alignment aid with red light laser is recommended for the alignment of transmitter and receiver (see chapter 8.3 „Aligning of Deflecting Mirrors with the laser alignment aid“).

- ↳ Note that the distance between the transmitter and the first Deflecting Mirror cannot be larger than 3 m.

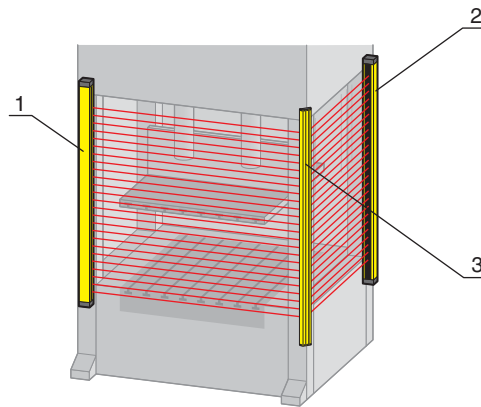

- 1 Transmitter
- 2 Receiver
- 3 UM60 Deflecting Mirror

Figure 6.10: Arrangement with Deflecting Mirror for 2-side guarding of a point of operation

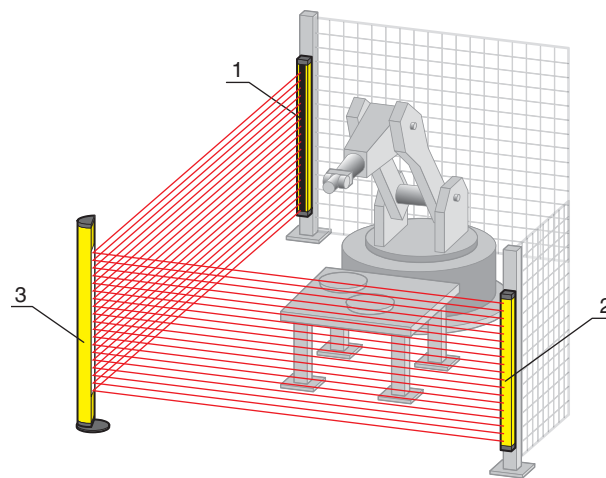

- 1 Transmitter
- 2 Receiver
- 3 UMC Deflecting Mirror Column

Figure 6.11: Arrangement with Deflecting Mirror Columns for two-side guarding of a point of operation

6.3.2 MLC-PS protective screen

If there is a risk that the protective plastic screens of the safety sensors could get damaged, e.g. by welding sparks, placing the additional, easy-to-replace MLC-PS protective screen in front of the safety sensors can protect the device protective screen and considerably increase the availability of the safety sensor. Mounting is performed using special clamp brackets, which are fastened on the lateral slot, via an Allen screw accessible from the front on each. The range of the safety sensor is reduced by approx. 5%; when protective screens are used on the transmitter and the receiver it is reduced by 10%. Mounting bracket sets with 2 and 3 clamp brackets are available.



If the length equals 1200 mm or higher, 3 clamp brackets are recommended.

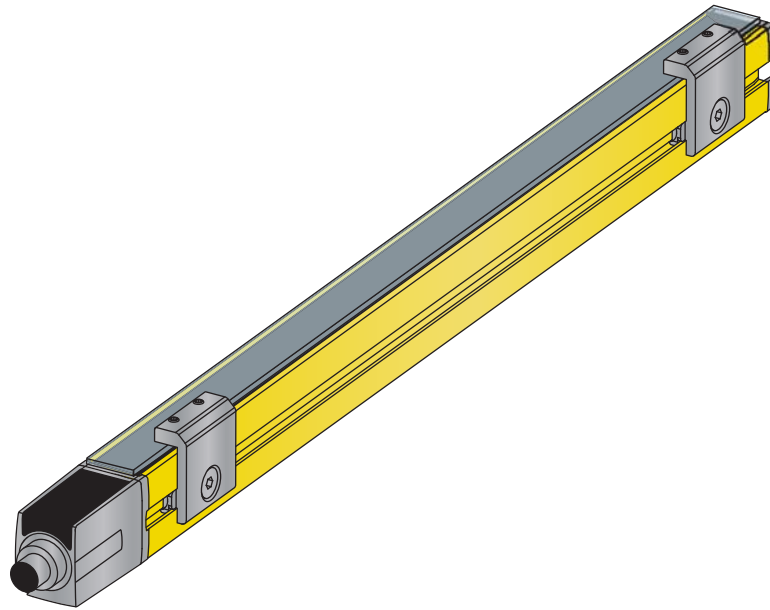

Figure 6.12: MLC-PS protective screen fastened with MLC-2PSF clamp bracket

7 Electrical connection

WARNING

Faulty electrical connection or improper function selection may result in serious injury!

- ↳ Only allow competent persons to perform the electrical connection.
- ↳ For access guarding, activate the start/restart interlock and make certain that it cannot be unlocked from within the danger zone.
- ↳ Select the functions so that the safety sensor can be used as intended (see chapter 2.1).
- ↳ Select the safety-relevant functions for the safety sensor (see chapter 4 „Functions“).
- ↳ Always loop both safety related switching outputs OSSD1 and OSSD2 into the work circuit of the machine.
- ↳ Signal outputs must not be used for switching safety-relevant signals.

7.1 Pin assignment transmitter and receiver

7.1.1 MLC 300 transmitter

MLC 300 transmitters are equipped with a 5-pin M 12 connector.

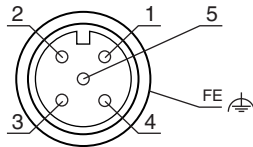

Figure 7.1: Pin assignment transmitter

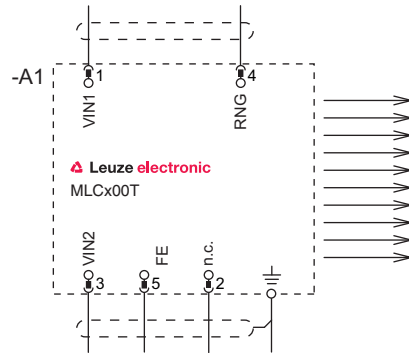

Figure 7.2: Connection diagram transmitter

Table 7.1: Pin assignment transmitter

Pin	Core color (CB-M12-xx000E-5GF)	Transmitter
1	brown	VIN1 - supply voltage
2	white	n.c.
3	Blue	VIN2 - supply voltage
4	black	RNG - range
5	gray	FE - functional earth, shield
Shield		FE - functional earth, shield

The polarity of the supply voltage selects the transmission channel of the transmitter:

- VIN1 = +24 V, VIN2 = 0 V: transmission channel C1
- VIN1 = 0 V, VIN2 = +24 V: transmission channel C2

The wiring of pin 4 determines the transmitting power and thereby the range:

- Pin 4 = +24 V: standard range
- Pin 4 = 0 V or open: reduced range

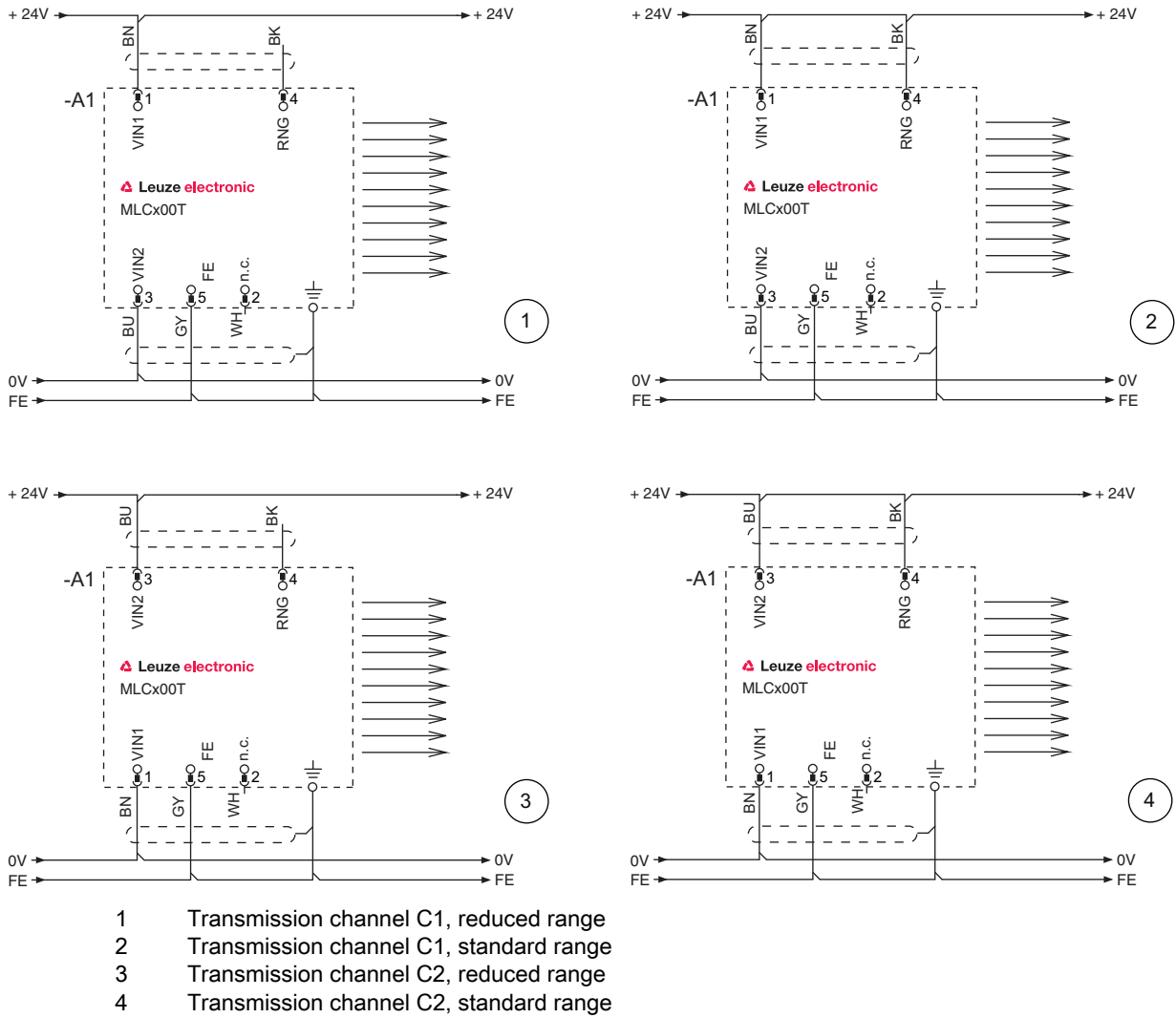

Figure 7.3: Connection examples transmitter



For special EMC influences, the use of shielded cables is recommended.

7.1.2 MLC 310 receiver

MLC 310 receivers are equipped with a 5-pin M 12 connector.

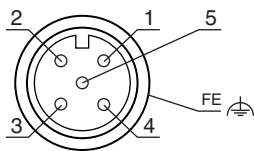

Figure 7.4: Pin assignment receiver

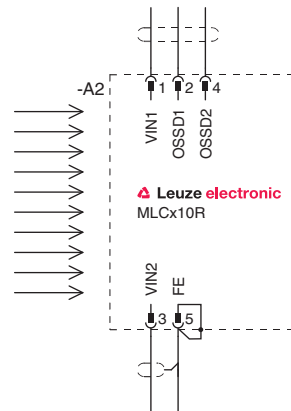

Figure 7.5: Connection diagram receiver

Table 7.2: MLC 310 receiver pin assignment

Pin	Core color (CB-M12-xx000E-5GF)	Receivers
1	brown	VIN1 - supply voltage
2	white	OSSD1 - safety-related switching output
3	Blue	VIN2 - supply voltage
4	black	OSSD2 - safety-related switching output
5	gray	FE - functional earth, shield Wired in device interior on the housing
Shield		FE - functional earth, shield

The polarity of the supply voltage selects the transmission channel of the receiver:

- VIN1 = +24 V, VIN2 = 0 V: transmission channel C1
- VIN1 = 0 V, VIN2 = +24 V: transmission channel C2



For special EMC influences, the use of shielded cables is recommended.

7.2 Circuit diagram examples

7.2.1 MLC 310 circuit diagram example

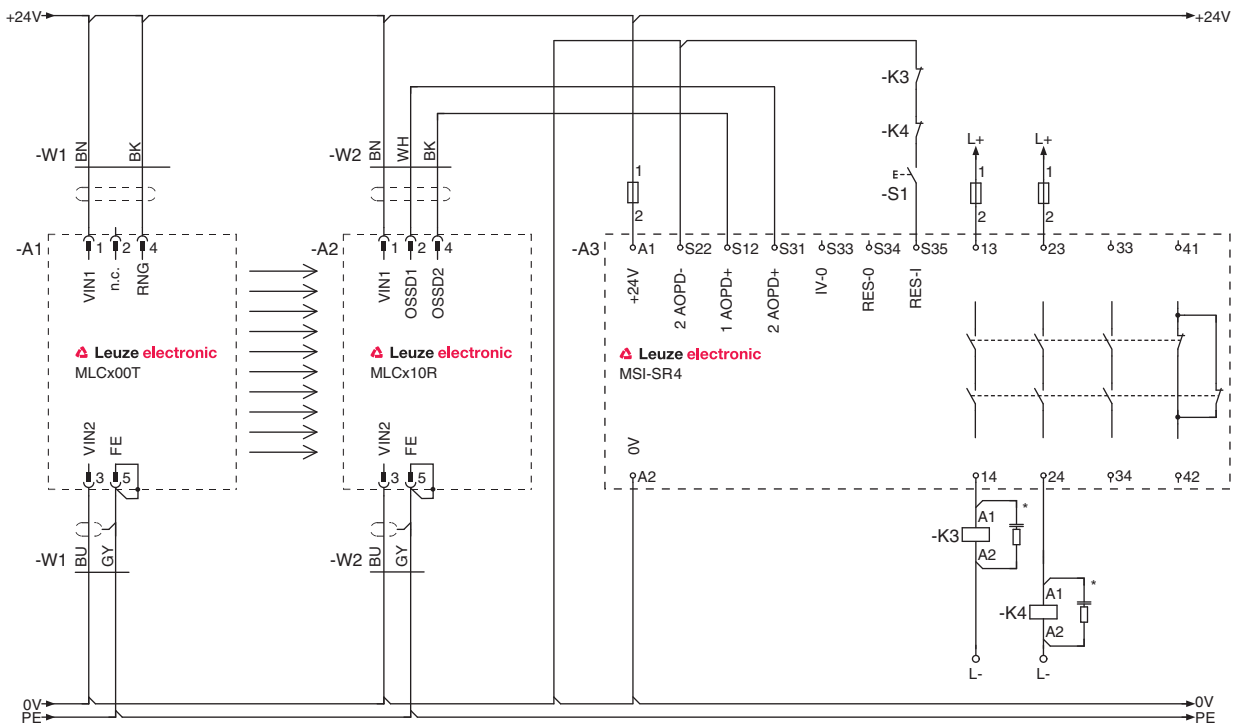

Figure 7.6: Circuit diagram example with downstream MSI-SR4 Safety Relay

8 Starting up the device

WARNING

Improper use of the safety sensor may result in serious injury!

- ↳ Make certain that the entire device and the integration of the Optoelectronic Protective Device was inspected by competent and instructed persons.
- ↳ Make certain that a dangerous process can only be started while the safety sensor is switched on.

Prerequisites:

- Safety sensor mounted (see chapter 6 „Mounting“) and connected (see chapter 7 „Electrical connection“) correctly
 - Operating personnel were instructed in proper use.
 - Dangerous process is switched off, outputs of the safety sensor are disconnected, and the system is protected against being switched back on
- ↳ After start-up, check the function of the safety sensor (see chapter 9.1 „Before the initial start-up and following modifications“).

8.1 Switching on

Requirements for the supply voltage (power supply unit):

- Reliable mains separation is ensured.
- Current reserve of at least 2 A is available.

↳ Switch on the safety sensor.

The safety sensor performs a self test.

Check operational readiness of sensor

↳ Check whether LED1 is permanently lit green or red (see table 3.3).

The safety sensor is ready for use.

8.2 Aligning the sensor

NOTICE

Faulty or incorrect alignment may result in an operating fault!

- ↳ The alignment performed during start-up should only be performed by qualified personnel.
- ↳ Observe the data sheets and mounting instructions of the individual components.

Prealignment

Fasten the transmitter and receiver in a vertical or horizontal position and at the same height so that

- the front screens are directed at each other.
- the transmitter and receiver connections point in the same direction.
- the transmitter and receiver are arranged parallel to each other, i.e. they are the same distance from each other at the beginning and end of the device.

Alignment can be performed with a clear protective field by observing the LEDs and the 7-segment display (see chapter 3.3 „Display elements“).

↳ Loosen the screws on the mounting brackets or Device Columns.



Loosen the screws only enough so that the devices can just be moved.

↳ Turn the receiver to the left until LED1 still flashes green but does not yet illuminate red. If necessary, you may have to turn the transmitter beforehand. The receiver with activated alignment display shows flashing segments in the 7-segment display, if applicable.

↳ Note the value of the twist angle.

- ↵ Turn the receiver to the right until LED1 still flashes green but does not yet illuminate red.
- ↵ Note the value of the twist angle.
- ↵ Set the optimum position of the receiver. This lies in the middle of the two values for the twist angle to the left and right.
- ↵ Tighten the fastening screws of the receiver.
- ↵ Now align the transmitter according to the same method, paying attention to the display elements of the receiver while doing so (see chapter 3.3.2 „Operating indicators on the MLC 310 receiver“, see chapter “”).

8.3 Aligning of Deflecting Mirrors with the laser alignment aid

When using Deflecting Mirrors for multiple-side point of operation guarding and access guarding in particular, an external laser alignment aid is recommended (see table 15.5).



With its clearly visible red light spot, the external laser alignment aid facilitates the correct setting of the transmitter and receiver as well as the Deflecting Mirrors.

- ↵ Fasten the laser alignment aid on top on the side groove of the transmitter (mounting instructions are included in the accessories).
- ↵ Switch on the laser. Take note of the operating instructions of the laser alignment aid concerning the safety notices and the activation of the laser alignment aid.
- ↵ Loosen the mounting bracket of the transmitter and turn or tilt or pitch the device so that the laser spot strikes the top of the first Deflecting Mirror (see chapter 6.2.2 „Definition of directions of movement“).
- ↵ Now set the laser below on the transmitter and adjust it so that the laser spot strikes the bottom of the Deflecting Mirror.
- ↵ Now set the laser back up top on the transmitter and check if the laser spot still strikes the top of the Deflecting Mirror. If it does not, the mounting height of the transmitter must be changed, if applicable.
- ↵ Repeat the process until the laser strikes the respective point of the Deflecting Mirror, both on top and on bottom.
- ↵ Turn, tilt or pitch the Deflecting Mirror so that the laser spot strikes either the next Deflecting Mirror or the receiver in both positions.
- ↵ Repeat the process in reverse after setting the laser alignment aid above and below on the receiver. The laser beam must strike the transmitter in both cases if the receiver has been correctly aligned.
- ↵ Remove the laser alignment aid from the safety sensor.

The protective field is free. LED1 on the receiver is permanently lit green. The OSSDs switch on.

9 Testing

 **WARNING**

A running machine may result in serious injury!

↪ Make certain that, during all conversions, maintenance work and inspections, the system is securely shut down and protected against being restarted.

The safety sensors must be exchanged after a maximum of 20 years.

- ↪ Always exchange entire safety sensors.
- ↪ For the tests, observe nationally applicable regulations.
- ↪ Document all tests in a comprehensible manner.

9.1 Before the initial start-up and following modifications

 **WARNING**

Unpredictable machine behavior during initial start-up may result in serious injury!

↪ Make certain that there are no people in the danger zone.

Acc. to IEC TS 62046 and national regulations (e.g. EU directive 2009/104/EC), tests are to be performed by competent persons in the following situations:

- Prior to the initial start-up
- Following modifications to the machine
- After longer machine downtime
- Following retrofitting or new configuration of the machine
- ↪ Test the effectiveness of the shut-down function in all operating modes of the machine acc. to the following checklist.
- ↪ Document all tests in a comprehensible manner and include the configuration of the safety sensor along with the data for the safety- and minimum distances in the documentation.
- ↪ Before they begin work, train the operators on their respective tasks. The training is the responsibility of the operating company.
- ↪ Attach notices regarding daily testing in the respective national language of the operator on the machine in a highly visible location, e.g. by printing out the corresponding chapter (see chapter 9.3).
- ↪ Check whether the safety sensor was correctly selected acc. to the locally applicable regulations and directives.
- ↪ Check whether the safety sensor is operated acc. to the specified environmental conditions (see chapter 14).
- ↪ Make certain that the safety sensor is protected against overcurrent.
- ↪ Perform a visual inspection for damage and test the electrical function (see chapter 9.2).

Minimum requirements for the power supply unit:

- Safe mains separation
- At least 2 A current reserve
- Power-failure bridging for at least 20 ms

Not until proper function of the Optoelectronic Protective Device is ascertained may it be integrated in the control circuit of the system.



As a safety inspection, Leuze electronic offers testing by a competent person prior to the initial start-up in selected countries (see chapter 13).

9.1.1 Checklist - to be performed prior to the initial start-up and following modifications

Tester: competent person

Table 9.1: Checklist - to be performed prior to the initial start-up and following modifications

Check:	Yes	No
Are all standards and guidelines named in this document and machine-specific standards observed?		
Does the Declaration of Conformity of the machine include a listing of these documents?		
Does the safety sensor satisfy the safety-related capability (PL, SIL, category) as required by the risk assessment?		
Are both safety-related switching outputs (OSSDs) integrated in the downstream machine control acc. to the required safety category?		
Are the switching elements (e.g. contactors) with positive-guided contacts that are controlled by the safety sensor monitored by a feedback circuit (EDM)?		
Does the electrical wiring match the circuit diagrams?		
Have the required protective measures against electrical shock been effectively implemented?		
Has the maximum stopping time of the machine been remeasured and recorded in the machine documents?		
Is the required safety distance (protective field of the safety sensor to the next hazard location) maintained?		
Are all hazardous locations of the machine accessible only through the protective field of the safety sensor? Are all additional protective devices (e.g. safety guards) correctly mounted and protected against tampering?		
Is the command device for unlocking the start/restart interlock of the machine mounted in accordance with specifications?		
Is the safety sensor correctly aligned and are all fastening screws and plugs secure?		
Are safety sensor, connecting cable, plug, protection caps and command devices undamaged and without any sign of manipulation?		
Has the effectiveness of the protective function been checked for all operating modes of the machine by means of a function test?		
Is the reset button for resetting the machine mounted outside of the danger zone in accordance with specifications in such a way that it cannot be reached from within the danger zone? Can the entire danger zone be seen from the place at which the reset button is installed?		
Does the interruption of an active light beam with a test object provided for this purpose cause the dangerous movement to stop?		
When the AOPD is separated from its supply voltage, does the dangerous movement stop, and, after the supply voltage has been restored, is it necessary to actuate the reset button to reset the machine?		
Is the safety sensor effective during the entire dangerous movement of the machine?		
Are the notices for daily testing of the safety sensor legible to the operator and are they located in a highly visible location?		



If you answer one of the items on the check list (see table 9.1) with *no*, the machine must no longer be operated.

9.2 To be performed periodically by competent persons

The reliable interaction of safety sensor and machine must be periodically tested by competent persons in order to detect changes to the machine or impermissible tampering with the safety sensor. Testing intervals are determined by nationally applicable regulations (recommendation acc. to IEC/TS 62046: 6 months).

- ↪ Have all tests performed by competent persons.
- ↪ Observe the nationally applicable regulations and the time periods specified therein.

 As a safety inspection, Leuze electronic offers periodic testing by a competent person in selected countries (see chapter 13).

9.3 Daily or at change of shift by the operator

The function of the safety sensor must be checked daily, at change of shifts, and at each change of machine operating mode as specified in the following check list so that damage or unauthorized manipulation can be detected.

 WARNING
Unpredictable machine behavior during the test may result in serious injury!
↪ Make certain that there are no people in the danger zone.

9.3.1 Check list – daily or at change of shift

 WARNING
Severe injuries can result if the machine is operated when faults occur during daily testing!
↪ Have the entire machine inspected by a competent person (see chapter 9.1).

Tester: authorized operator or instructed person

Table 9.2: Check list – daily or at change of shift

Check:	Yes	No
Is the safety sensor aligned correctly? Are all fastening screws tightened and all connectors secured?		
Are safety sensor, connecting cable, plug and command devices undamaged and without any sign of manipulation?		
Are all point of operations at the machine accessible only through one or more protective fields of safety sensors?		
Are all additional protective devices mounted correctly (e.g., safety guard)?		
Does the start/restart interlock prevent the automatic start-up of the machine after the safety sensor has been switched on or triggered?		
↪ During operation, interrupt an active light beam with a test object provided for this purpose (see figure 9.1). Is the dangerous movement shut down immediately?		

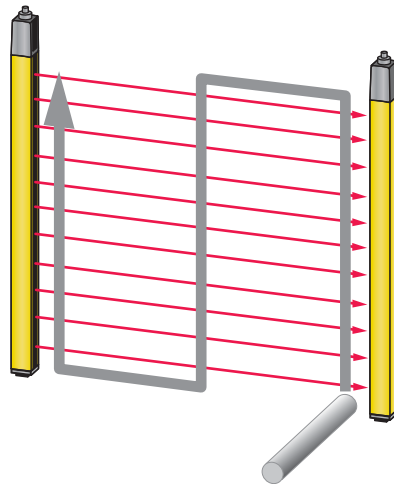

Figure 9.1: Checking the protective field function with test rod (only for safety light curtains with a resolution of 14 to 40 mm)



If you answer one of the items on the check list (see table 9.2) with *no*, the machine must no longer be operated.

- ↪ Stop the dangerous state.
- ↪ Check transmitter, receiver and, if applicable, deflecting mirrors for damage or manipulation.
- ↪ Interrupt all light beams at different distances from the transmitter and receiver with the test rod from a position outside the danger zone (see figure 9.1) and ensure that the machine cannot be started with an interrupted light beam.
- ↪ Start the machine.
- ↪ Ensure that the dangerous state is stopped as soon as an active light beam is interrupted with a test object provided for this purpose.

10 Maintenance

NOTICE**Faulty operation if transmitter and receiver are soiled!**

The surfaces of the front screen of transmitters, receivers and, where applicable, Deflecting Mirror must not be scratched or roughened at the positions where beams enter and exit.

↪ Do not use chemical cleaners.

Prerequisites for cleaning:

- The system is safely shut down and protected against restart.
- ↪ Clean the safety sensor regularly depending on the degree of contamination.

11 Rectifying the fault

11.1 What to do in case of failure?

After switching the safety sensor on, the display elements (see chapter 3.3) assist in checking the correct functionality and in faultfinding.

In case of failure, you can determine the fault from the LED displays or read a message from the 7-segment display. With the error message you can determine the cause of the fault and initiate measures to rectifying it.

NOTICE
If the safety sensor responds with an error display, you will often be able to eliminate the cause yourself.
↪ Switch off the machine and leave it switched off.
↪ Analyze the cause of the error using the following tables (see table 11.1, see table 11.2) and eliminate the error.
↪ If you are unable to rectify the fault, contact the Leuze electronic branch responsible for you or call the Leuze electronic customer service (see chapter 13 „Service and support“).

11.2 Operating displays of the LEDs

Table 11.1: Transmitter LED displays - causes and measures

LED	State	Cause	Measure
Transmitter			
LED1	OFF	Transmitter without supply voltage	Check the power supply unit and the electrical connection. Exchange the power supply unit, if applicable.
	red	Transmitter defective	Exchange the transmitter.

Table 11.2: Receiver LED displays - causes and measures

LED	State	Cause	Measure
LED1	OFF	Device failed	Replace the device.
	red	Alignment incorrect or protective field interrupted	Remove all objects from the protective field. Align the transmitter and receiver to each other or place blanked objects correctly concerning size and position.
	red (LEDs on transmitter: both green)	Receiver is set on C1, transmitter on C2	Set the transmitter and receiver on the same transmission channel and align both correctly.
	red (LED1 on transmitter: green)	Receiver is set on C2, transmitter on C1	Remove all objects from the protective field. Align the transmitter and receiver to each other or place blanked objects correctly concerning size and position.
	red, slowly flashing, approx. 1 Hz	External fault	Check the connection of the cables and the control signals.
	red, flashing fast, approx. 10 Hz	Internal fault	If restart fails, exchange the device.
	green, slowly flashing, approx. 1 Hz	Weak signal due to contamination or poor alignment	Clean the front screens and check the alignment of transmitter and receiver.

12 Disposing

↳ For disposal observe the applicable national regulations regarding electronic components.

13 Service and support

Telephone number for 24-hour standby service:

+49 (0) 702 573-0

Service hotline:

+49 (0) 8141 5350-111

Monday to Thursday, 8.00 a.m. to 5.00 p.m. (UTC+1)

Friday, 8.00 a.m. to 4.00 p.m. (UTC +1)

E-mail:

service.protect@leuze.de

Return address for repairs:

Service Center

Leuze electronic GmbH + Co. KG

In der Braike 1

D-73277 Owen/Germany

14 Technical data

14.1 General specifications

Table 14.1: Protective field data

Physical resolution [mm]	Range [m]		Protective field height [mm]	
	min.	max.	min.	max.
20	0	15	150	3000
30	0	10	150	3000
40	0	20	150	3000
90	0	20	450	3000

Table 14.2: Safety-relevant technical data

Type in accordance with IEC/EN 61496	Type 2
SIL in accordance with IEC 61508	SIL 1
SILCL in accordance with IEC/EN 62061	SILCL 1
Performance Level (PL) in accordance with EN ISO 13849-1	PL c
Category in accordance with EN ISO 13849-1	Cat. 2
Average probability of a failure to danger per hour (PFH _d)	5.06x10 ⁻⁸ 1/h
Service life (T _M)	20 years

Table 14.3: General system data

Connection technology	M12, 5-pin
Supply voltage U _v , transmitter and receiver	+24 V, ± 20 %, compensation necessary at 20 ms voltage dip, min. 250 mA (+ OSSD load)
Residual ripple of supply voltage	± 5 % within the limits of U _v
Current consumption - transmitter	50 mA
Current consumption receiver	150 mA (without load)
Common value for ext. fuse in the supply line for transmitter and receiver	2 A semi time-lag
Synchronization	Optical between transmitter and receiver
Safety class	III
Protection class	IP65
Temperature range, operation	0 ... 55 °C
Temperature range, storage	-25 ... 70 °C
Relative humidity (non- condensing)	0 ... 95 %

Vibration fatigue limit	5 g, 10 - 55 Hz in accordance with IEC/ EN 60068-2-6; amplitude 0.35 mm
Shock resistance	10 g, 16 ms in accordance with IEC/ EN 60068-2-6
Profile cross-section	29 mm x 35.4 mm
Dimensions	see figure 14.1 and see table 14.6
Weight	see table 14.6

Table 14.4: System data - transmitter

Transmitter diodes, class in accordance with EN 60825-1: 1994 + A1: 2002 + A2: 2001	1
Wavelength	940 nm
Pulse duration	800 ns
Pulse pause	1.9 μ s (min.)
Mean power	<50 μ W
Input current pin 4 (range)	Against +24 V: 10 mA Against 0 V: 10 mA

Table 14.5: Technical data of the electronic safety-related switching outputs (OSSDs) on the receiver

Safety-related PNP transistor outputs (short-circuit monitored, cross-circuit monitored)	Minimum	Typical	Maximum
Switching voltage high active ($U_v - 1.5V$)	18 V	22.5 V	27 V
Switching voltage low		0 V	+2.5 V
Switching current		300 mA	380 mA
Residual current		< 2 μ A	200 μ A ^{a)}
Load capacity			0.3 μ F
Load inductivity			2 H
Permissible wire resistance for load			<200 Ω ^{b)}
Permissible wire cross section		0.25 mm ²	
Permissible cable length between receiver and load			100 m
Test pulse width		60 μ s	340 μ s
Test pulse distance	(5 ms)	60 ms	
OSSD restart delay time after beam interruption		100 ms	

a) In the event of a failure (if the 0 V-cable is interrupted), each of the outputs behaves as a 120 k Ω resistor to U_v . A downstream safety PLC must not detect this as a logical "1".

b) Note the additional restrictions due to cable length and load current.



The safety-related transistor outputs perform the spark extinction. With transistor outputs, it is therefore neither necessary nor permitted to use the spark extinction circuits recommended by contactor or valve manufacturers (RC elements, varistors or recovery diodes), since these considerably extend the decay times of inductive switching elements.

14.2 Dimensions, weight, response time

Dimensions, weight and response time are dependent on

- the resolution
- the length

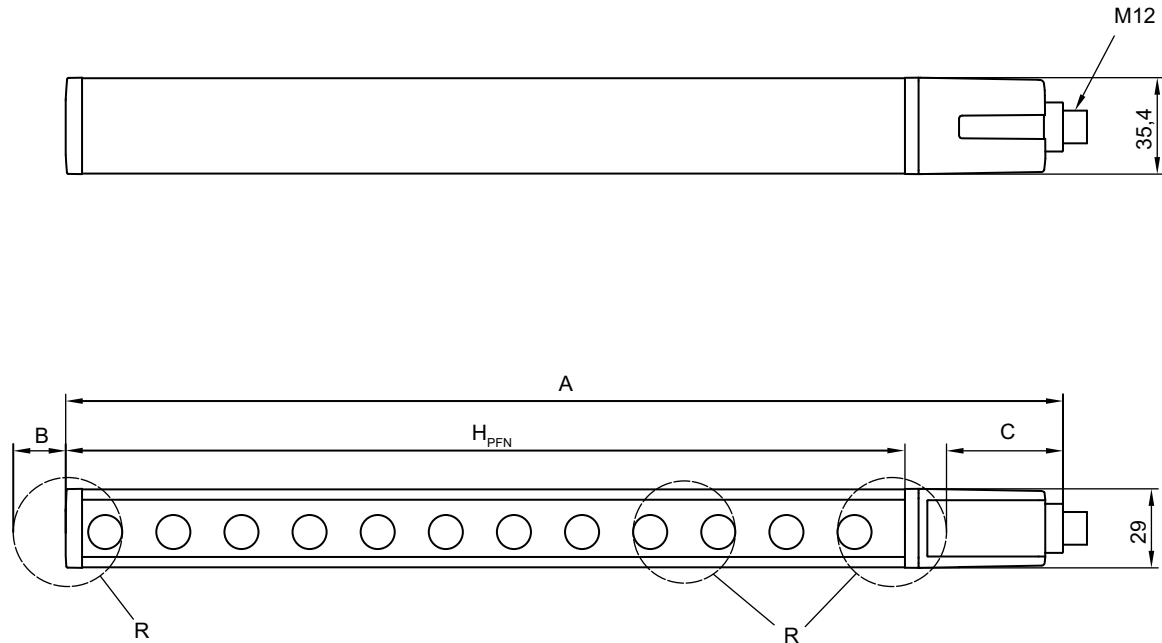

Figure 14.1: Dimensions of transmitter and receiver

Effective protective field height H_{PFE} goes beyond the dimensions of the optics area to the outer borders of the circles labeled with R.

Calculation of the effective protective field height

$$H_{PFE} = H_{PFN} + B - C + 66$$

- H_{PFE} [mm] = Effective protective field height
- H_{PFN} [mm] = Nominal protective field height (see table 14.6); this corresponds to the length of the yellow housing part
- A [mm] = Total height
- B [mm] = Additional dimensions for calculation of the effective protective field height (see table 14.7)
- C [mm] = Value for calculating the effective protective field height (see table 14.7)

Table 14.6: Dimensions (nominal protective field height), weight and response time

Device type	Transmitter and receiver			Receivers			
	Dimensions [mm]		Weight [kg]	Response time [ms] acc. to resolution			
Type	$H_{PFN}^a)$	$A=H_{PFN}+66^b)$		20 mm	30 mm	40 mm	90 mm
MLC...-150	150	216	0.30	4	3	3	-
MLC...-225	225	291	0.37	5	3	3	-
MLC...-300	300	366	0.45	7	4	4	-

Device type	Transmitter and receiver			Receivers			
	Dimensions [mm]		Weight [kg]	Response time [ms] acc. to resolution			
Type	H _{PFN} ^{a)}	A=H _{PFN} +66 ^{b)}		20 mm	30 mm	40 mm	90 mm
MLC...-450	450	516	0.60	9	5	5	3
MLC...-600	600	666	0.75	12	7	7	3
MLC...-750	750	816	0.90	14	8	8	4
MLC...-900	900	966	1.05	17	9	9	4
MLC...-1050	1050	1116	1.20	19	10	10	4
MLC...-1200	1200	1266	1.35	22	12	12	5
MLC...-1350	1350	1416	1.50	24	13	13	5
MLC...-1500	1500	1566	1.65	26	14	14	6
MLC...-1650	1650	1716	1.80	29	15	15	6
MLC...-1800	1800	1866	1.95	31	17	17	7
MLC...-1950	1950	2016	2.10	34	18	18	7
MLC...-2100	2100	2166	2.25	36	19	19	7
MLC...-2400	2400	2466	2.55	41	22	22	8
MLC...-2700	2700	2766	2.85	46	24	24	9
MLC...-3000	3000	3066	3.15	51	26	26	10

a) H_{PFN} = nominal protective field height = length of the yellow housing part

b) Total height, see figure 14.1

Table 14.7: Additional dimensions for calculating the effective protective field height

R = resolution	B	C
14 mm	0 mm	52 mm
20 mm	1.5 mm	48 mm
30 mm	13 mm	49 mm
40 mm	19 mm	43 mm
90 mm	44 mm	18 mm

14.3 Dimensional drawings: accessories

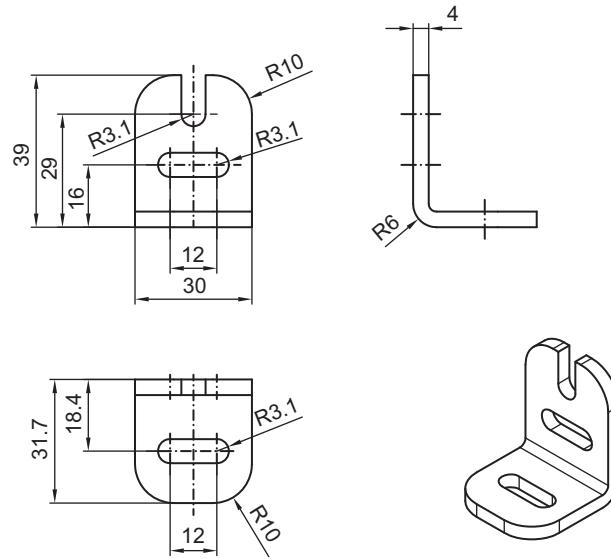

Figure 14.2: BT-L mounting bracket

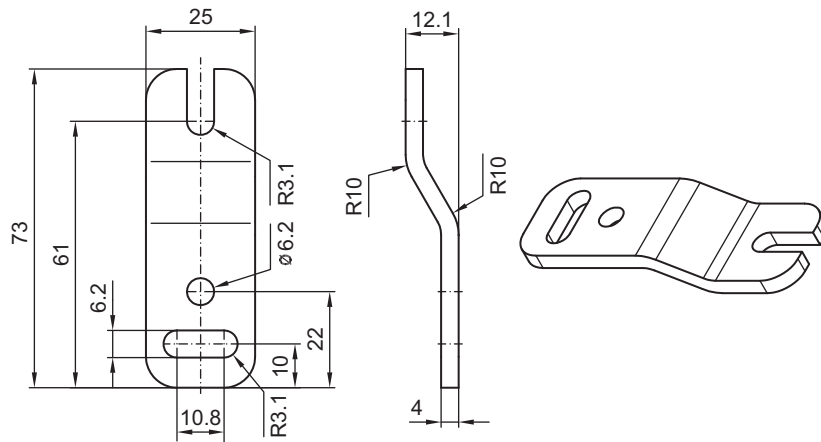

Figure 14.3: BT-Z parallel bracket

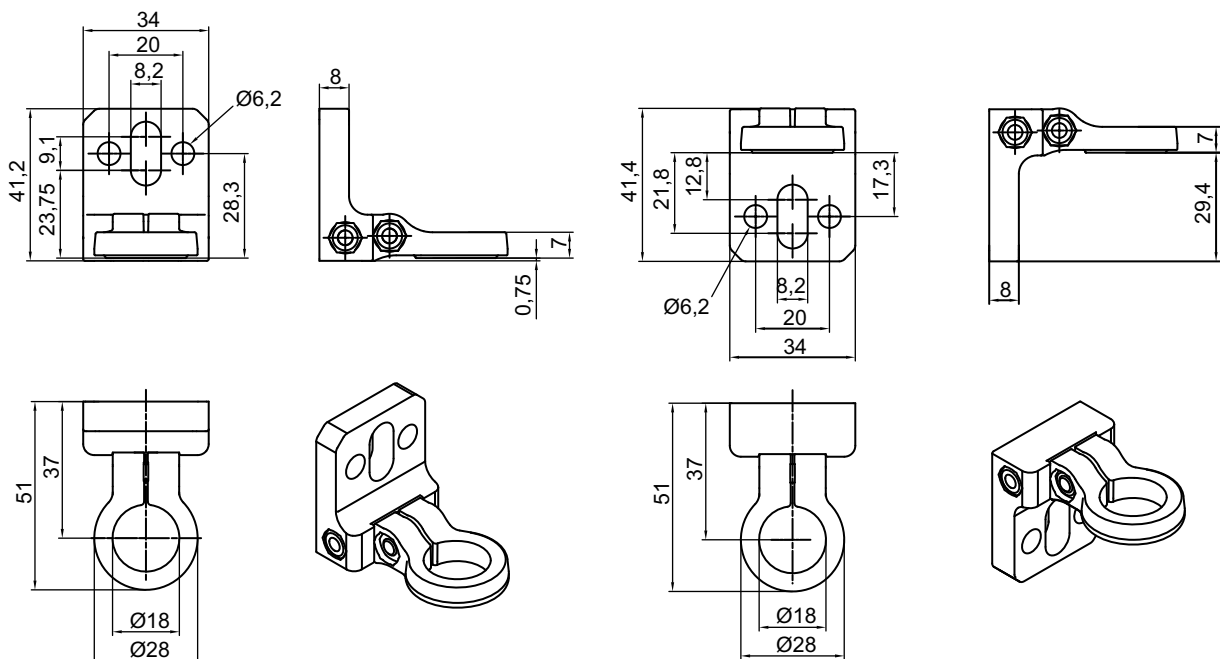

Figure 14.4: BT-R swivel mount

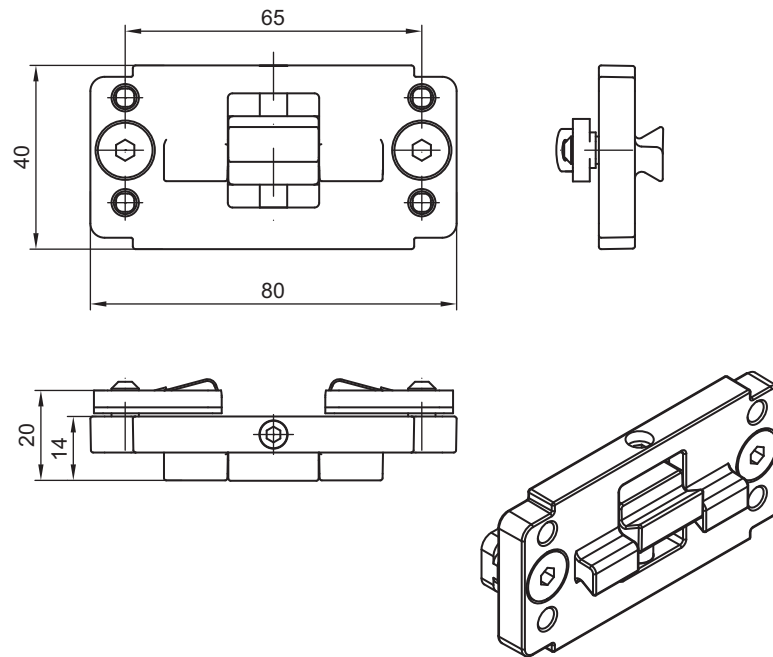

Figure 14.5: BT-P40 clamp bracket

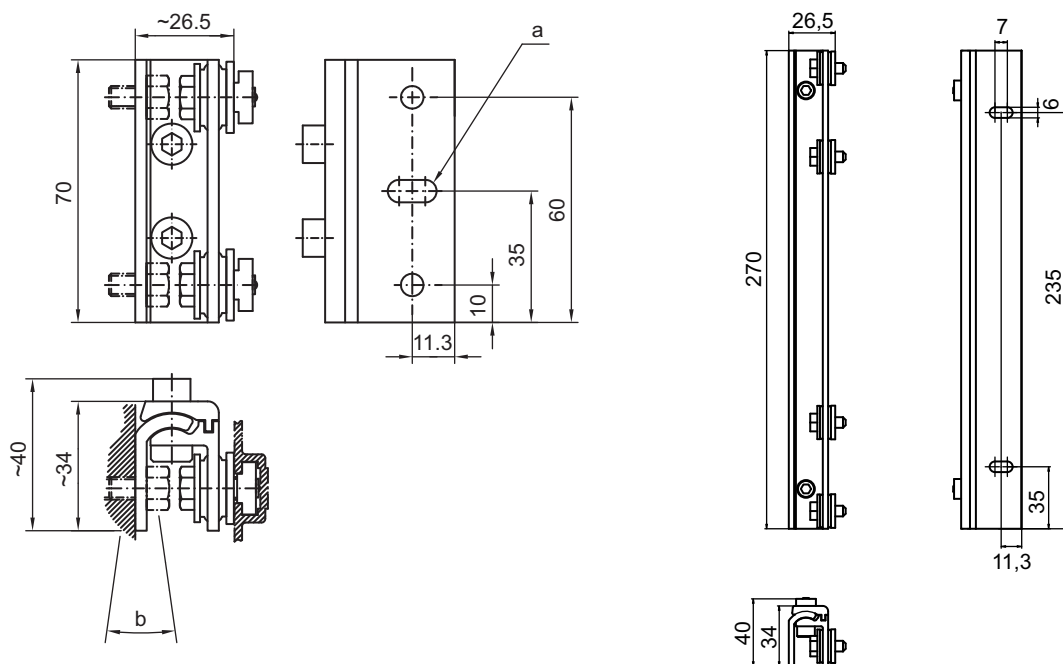

Figure 14.6: BT-SSD and BT-SSD-270 swiveling mounting brackets

15 Ordering information and accessories

Nomenclature

Part description:

MLCxyy-za-hhhh

Table 15.1: Article list

MLC	Safety sensor
x	Series: 3 for MLC 300
yy	Function classes: 00: Transmitter 10: Basic receiver - automatic restart
z	Device type: T: transmitter R: receiver
a	Resolution: 20: 20 mm 30: 30 mm 40: 40 mm 90: 90 mm
hhhh	Protective field height: 150 ... 3000: from 150 mm to 3000 mm

Table 15.2: Part descriptions, examples

Examples for part description	Features
MLC300T20-600	Type 2 transmitter, PL c, SIL 1, resolution 20 mm, protective field height 600 mm
MLC300T30-900	Type 2 transmitter, PL c, SIL 1, resolution 30 mm, protective field height 900 mm
MLC310R90-1500	Type 2 Basic receiver, PL c, SIL 1, resolution 90 mm, protective field height 1500 mm

Scope of delivery

- Transmitter including 2 sliding blocks, 1 instruction sheet
- Receiver incl. 2 sliding blocks, 1 self-adhesive notice sign "Important notices and notices for the machine operator", 1 connecting and operating instructions (PDF file on CD-ROM)

Table 15.3: Article numbers of MLC 300 transmitter depending on resolution and protective field height

Protective field height hhhh [mm]	20 mm MLC300T20-hhhh	30 mm MLC300T30-hhhh	40 mm MLC300T40-hhhh	90 mm MLC300T90-hhhh
150	68090201	68090301	68090401	-
225	68090202	68090302	68090402	-
300	68090203	68090303	68090403	-
450	68090204	68090304	68090404	68090904
600	68090206	68090306	68090406	68090906

Protective field height hhhh [mm]	20 mm MLC300T20-hhhh	30 mm MLC300T30-hhhh	40 mm MLC300T40-hhhh	90 mm MLC300T90-hhhh
750	68090207	68090307	68090407	68090907
900	68090209	68090309	68090409	68090909
1050	68090210	68090310	68090410	68090910
1200	68090212	68090312	68090412	68090912
1350	68090213	68090313	68090413	68090913
1500	68090215	68090315	68090415	68090915
1650	68090216	68090316	68090416	68090916
1800	68090218	68090318	68090418	68090918
1950	-	-	68090419	68090919
2100	-	-	68090421	68090921
2400	-	-	68090424	68090924
2700	-	-	68090427	68090927
3000	-	-	68090430	68090930

Table 15.4: Article numbers of MLC 310 receiver depending on resolution and protective field height

Protective field height hhhh [mm]	20 mm MLC310R20-hhhh	30 mm MLC310R30-hhhh	40 mm MLC310R40-hhhh	90 mm MLC310R90-hhhh
150	68091201	68091301	68091401	-
225	68091202	68091302	68091402	-
300	68091203	68091303	68091403	-
450	68091204	68091304	68091404	68091904
600	68091206	68091306	68091406	68091906
750	68091207	68091307	68091407	68091907
900	68091209	68091309	68091409	68091909
1050	68091210	68091310	68091410	68091910
1200	68091212	68091312	68091412	68091912
1350	68091213	68091313	68091413	68091913
1500	68091215	68091315	68091415	68091915
1650	68091216	68091316	68091416	68091916
1800	68091218	68091318	68091418	68091918
1950	-	-	68091419	68091919
2100	-	-	68091421	68091921

Protective field height hhhh [mm]	20 mm MLC310R20-hhhh	30 mm MLC310R30-hhhh	40 mm MLC310R40-hhhh	90 mm MLC310R90-hhhh
2400	-	-	68091424	68091924
2700	-	-	68091427	68091927
3000	-	-	68091430	68091930

Table 15.5: Accessories

Part no.	Article	Description
Connection cables for MLC 300 transmitter and MLC 310 receiver, shielded		
678055	CB-M12-5000E-5GF	Connection cable, 5-pin, 5 m long
678056	CB-M12-10000E-5GF	Connection cable, 5-pin, 10 m long
678057	CB-M12-15000E-5GF	Connection cable, 5-pin, 15 m long
678058	CB-M12-25000E-5GF	Connection cable, 5-pin, 25 m long
Connection cables for MLC 300 transmitter, unshielded		
Connection cables for MLC 300 transmitter and MLC 310 receiver, unshielded		
429087	CB-M12-5000-5GF	Connection cable, 5-pin, 5 m long
429280	CB-M12-10000-5GF	Connection cable, 5-pin, 10 m long
429088	CB-M12-15000-5GF	Connection cable, 5-pin, 15 m long
429089	CB-M12-25000-5GF	Connection cable, 5-pin, 25 m long
429281	CB-M12-50000-5GF	Connection cable, 5-pin, 50 m long
User-configurable connectors for MLC 300 transmitter and MLC 310 receiver		
429175	CB-M12-5GF	Cable socket, 5-pin, metal housing, shield on housing
Mounting technology		
429056	BT-2L	L mounting bracket, 2 pieces
429057	BT-2Z	Z mounting bracket, 2 pieces
429046	BT-2R1	360° swivel mount, 2 pieces incl. 1 MLC cylinder
424417	BT-2P40	Clamp bracket for slot mounting, 2 pieces
429058	BT-2SSD	Swivel mount with shock absorber, ± 8°, 70 mm long, 2 pieces
429059	BT-4SSD	Swivel mount with shock absorber, ± 8°, 70 mm long, 4 pieces
429049	BT-2SSD-270	Swivel mount with shock absorber, ± 8°, 270 mm long, 2 pieces
425740	BT-10NC60	Sliding block with M6 thread, 10 pieces
425741	BT-10NC64	Sliding block with M6 and M4 thread, 10 pieces
425742	BT-10NC65	Sliding block with M6 and M5 thread, 10 pieces
Device Columns		

Part no.	Article	Description
549855	UDC-900-S2	Device Column, U-shaped, profile height 900 mm
549856	UDC-1000-S2	Device Column, U-shaped, profile height 1000 mm
549852	UDC-1300-S2	Device Column, U-shaped, profile height 1300 mm
549853	UDC-1600-S2	Device Column, U-shaped, profile height 1600 mm
549854	UDC-1900-S2	Device Column, U-shaped, profile height 1900 mm
549857	UDC-2500-S2	Device Column, U-shaped, profile height 2500 mm
Deflecting Mirror Columns		
549780	UMC-1000-S2	Continuous Deflecting Mirror Column 1000 mm
549781	UMC-1300-S2	Continuous Deflecting Mirror Column 1300 mm
549782	UMC-1600-S2	Continuous Deflecting Mirror Column 1600 mm
549783	UMC-1900-S2	Continuous Deflecting Mirror Column 1900 mm
Deflecting Mirror		
529601	UM60-150	Deflecting Mirror, mirror length 210 mm
529603	UM60-300	Deflecting Mirror, mirror length 360 mm
529604	UM60-450	Deflecting Mirror, mirror length 510 mm
529606	UM60-600	Deflecting Mirror, mirror length 660 mm
529607	UM60-750	Deflecting Mirror, mirror length 810 mm
529609	UM60-900	Deflecting Mirror, mirror length 960 mm
529610	UM60-1050	Deflecting Mirror, mirror length 1110 mm
529612	UM60-1200	Deflecting Mirror, mirror length 1260 mm
529613	UM60-1350	Deflecting Mirror, mirror length 1410 mm
529615	UM60-1500	Deflecting Mirror, mirror length 1560 mm
529616	UM60-1650	Deflecting Mirror, mirror length 1710 mm
529618	UM60-1800	Deflecting Mirror, mirror length 1860 mm
430105	BT-2UM60	Mounting bracket for UM60, 2 pieces
Protective screens		
347070	MLC-PS150	Protective screen, length 148 mm
347071	MLC-PS225	Protective screen, length 223 mm
347072	MLC-PS300	Protective screen, length 298 mm
347073	MLC-PS450	Protective screen, length 448 mm
347074	MLC-PS600	Protective screen, length 598 mm
347075	MLC-PS750	Protective screen, length 748 mm
347076	MLC-PS900	Protective screen, length 898 mm
347077	MLC-PS1050	Protective screen, length 1048 mm

Part no.	Article	Description
347078	MLC-PS1200	Protective screen, length 1198 mm
347079	MLC-PS1350	Protective screen, length 1348 mm
347080	MLC-PS1500	Protective screen, length 1498 mm
347081	MLC-PS1650	Protective screen, length 1648 mm
347082	MLC-PS1800	Protective screen, length 1798 mm
429038	MLC-2PSF	Mounting device for MLC protective screen, 2 pieces
429039	MLC-3PSF	Mounting device for MLC protective screen, 3 pieces
Laser alignment aids		
560020	LA-78U	External laser alignment aid
520004	LA-78UDC	External laser alignment aid for fastening in Device Column
Test rods		
349945	AC-TR14/30	Test rod 14/30 mm
349939	AC-TR20/40	Test rod 20/40 mm

16 EC Declaration of Conformity



the **sensor** people

EG-KONFORMITÄTS- ERKLÄRUNG (ORIGINAL)	EC DECLARATION OF CONFORMITY (ORIGINAL)	DECLARATION CE DE CONFORMITE (ORIGINAL)
Der Hersteller	The Manufacturer	Le constructeur
	Leuze electronic GmbH + Co. KG In der Braike 1, PO Box 1111 73277 Owen, Germany	
erklärt, dass die nachfolgend aufgeführten Produkte den einschlägigen Anforderungen der genannten EG-Richtlinien und Normen entsprechen.	declares that the following listed products fulfil the relevant provisions of the mentioned EC Directives and standards.	déclare que les produits identifiés suivants sont conformes aux directives CE et normes mentionnées.
Produktbeschreibung:	Description of product:	Description de produit:
Sicherheits- Lichtvorhang, Berührungslos wirkende Schutzeinrichtung, Sicherheitsbauteil nach 2006/42/EG Anhang IV MLC 300, MLC 500 Seriennummer siehe Typschild	Safety Light Curtain, Active opto-electronic protective device, safety component in acc. with 2006/42/EC annex IV MLC 300, MLC 500 Serial no. see name plates	Barrière immatérielle de sécurité, Équipement de protection électrosensible, Élément de sécurité selon 2006/42/CE annexe IV MLC 300, MLC 500 N° série voir plaques signalétiques
Angewandte EG-Richtlinie(n):	Applied EC Directive(s):	Directive(s) CE appliquées:
2006/42/EG 2004/108/EG	2006/42/EC 2004/108/EC	2006/42/CE 2004/108/CE
Angewandte Normen:	Applied standards:	Normes appliquées:
EN 61496-1:2009; IEC 61496-2:2006; EN 55011/A2:2007; EN 50178:1997;	EN ISO 13849-1: 2008 (Kat. 4, Ple)	
Benannte Stelle:	Notified Body:	Organisme notifié:
	TÜV-SÜD PRODUCT SERVICE GmbH Zertifizierungsstelle Ridlerstraße 65 D-80339 München	
Bevollmächtigter für die Zusammenstellung der technischen Unterlagen:	Authorized person to compile the technical file:	Personne autorisée à constituer le dossier technique:
	André Thieme; Leuze electronic GmbH + Co. KG Liebigstr. 4; 82256 Fuerstenfeldbruck; Germany	

Owen, 13.08.2013
Datum / Date / Date



Ulrich Balbach, Geschäftsführer / Director / Directeur

Leuze electronic GmbH + Co. KG
In der Braike 1
D-73277 Owen
Telefon +49 (0) 7021 578
Telefax +49 (0) 7021 57899
info@leuze.de
www.leuze.com

Leuze electronic GmbH + Co. KG, Sitz Owen, Registergericht Stuttgart, HRA 23071
Persönlich haftende Gesellschafterin Leuze electronic Geschäftsführung GmbH,
Sitz Owen, Registergericht Stuttgart, HRB 230550
Geschäftsführer: Ulrich Balbach/Dr. Matthias Kirchherr
USt-IdNr. DE 145912521 Zollnummer 2554232
Es gelten ausschließlich unsere aktuellen Verkaufs- und Lieferbedingungen
Only our current Terms and Conditions of Sale and Delivery shall apply

Nr. 609473-2013/08