



### Model Number

**IPC03-30W**

Data carrier

### Features

- Battery-free data carrier
- 32 bit fixcode
- 928 bits computer memory available
- Readable and writable from both sides
- Protection degree IP67
- Mounting holes for simple installation

### Dimensions

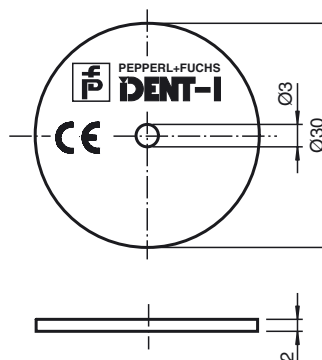

### Technical data

#### General specifications

Operating frequency	125 kHz
Transfer rate	2 kBit/s
Distance	distance tables, see introduction

#### Memory

Type/Size	EEPROM 928 Bit ROM 32 Bit
Read cycles	unlimited
Write cycles	> 100000
Data retention period	10 years at 55 °C

#### Ambient conditions

Ambient temperature	-25 ... 70 °C (248 ... 343 K)
Storage temperature	-40 ... 90 °C (233 ... 363 K)

#### Mechanical specifications

Protection degree	IP67 according to EN 60529
Material	
Housing	PC

### Notes

The transponder can be read and written from either side.